

Title I, Part C Education of Migratory Children



Migrant Education Program Identification and Recruitment Manual

April 2, 2012, U.S. Department of Education, Washington, D.C.



This manual was produced with the assistance of the U.S. Department of Education Contract No. ED-08-CO-0111 with Center for Migrant Education at Texas State University-San Marcos. Irene Harwarth, Management and Program Analyst, served as the contracting officer's representative. No official endorsement by the U.S. Department of Education of any product, commodity, service or enterprise mentioned in this publication is intended or should be inferred. This manual contains Web site addresses for information created and maintained by private organizations. This information is provided for the reader's convenience. The U.S. Department of Education is not responsible for controlling or guaranteeing the accuracy, relevance, timeliness or completeness of this outside information. Further, the inclusion of information or Web site addresses does not reflect the importance of the organization, nor is it intended to endorse any views expressed, or products or services.

Office of Migrant Education

Lisa R. Ramirez, Ed.D.

Director

Table of Contents

Table of Contents.....	iii
Abbreviations	vii
Foreword.....	viii
Preface	ix
Purpose.....	ix
How to Use the Manual.....	xii
PART I: The Recruiter Manual.....	1
Chapter 1. Background and Overview of the Migrant Education Program	2
Children of Migratory Farmworkers and Fishers	2
Purpose of the Migrant Education Program	4
Who is Eligible for the MEP?.....	5
The Importance of ID&R in Determining Eligibility for the MEP	6
Organization of the MEP	7
Conclusion	9
Recruiter Checklist.....	9
Chapter 2. The MEP Recruiter	10
Recruitment Duties and Responsibilities	10
Characteristics of a Successful Recruiter.....	11
Lessons Learned: Recruiter Roles & Responsibilities	12
Conclusion	14
Recruiter Checklist.....	14
Chapter 3. Learning to Recruit.....	15
Learning about Identification and Recruitment	15
Knowledge and Skills of Identification and Recruitment.....	15
New Recruiter Training.....	17
On-the-Job Training	20
Advanced Training and Ongoing Professional Development.....	21
Conclusion	22
Recruiter Checklist.....	23
Chapter 4. Building a Recruitment Network	24
Finding Migrant Children.....	24
Conducting Research.....	24
Terminology Used to Describe Migrant Farmworkers.....	26
Identifying Important Information Sources.....	27
Community-based Organizations and Commercial Establishments	30
Building Relationships and Gathering Data	33
Conclusion	39
Recruiter Checklist.....	39
Chapter 5. Developing Action Plans and Contacting Families.....	40
Developing State, Local, and Individual ID&R Action Plans	40
Locating Migrant Families and Youth	44
Employer-based Recruitment.....	45
School and Community-based Recruitment.....	46

Safety While Recruiting	49
Conclusion.....	51
Recruiter Checklist	52
Chapter 6. Interviewing Migrant Families and Youth.....	53
The Recruiter as Interviewer	53
Sample Interview Script	53
Visiting Families or Youth	57
Difficulties While Interviewing.....	62
Lessons Learned: Interviewing Migrant Families and Out-of-School Youth.....	67
Conclusion.....	69
Recruiter Checklist	70
Chapter 7. Determining Eligibility.....	71
The Importance of Accurate Determinations.....	71
The Recruiter’s Role	71
Primary Resources to Help Determine Eligibility	72
Basic Child Eligibility Factors Chart	78
Comprehensive Eligibility Training.....	79
Making Eligibility Decisions.....	79
Determining Eligibility in Difficult Cases.....	80
The Recruiter’s Instinct	82
Lessons Learned: Eligibility.....	83
Conclusion.....	86
Recruiter Checklist	88
Chapter 8. Completing the Certificate of Eligibility.....	89
Documenting Eligibility	89
The Purpose of a COE.....	89
Required Data Sections	91
Instructions for the National COE	93
Completing the Data Elements of the COE	94
Required Data Section.....	97
Processing and Storing the COE	107
Record Keeping Requirements.....	108
Lessons Learned: Completing COEs.....	111
Conclusion.....	111
Recruiter Checklist	111
PART II: The Administrator Manual	113
Chapter 9. Hiring and Training Recruiters	114
Central Role of ID&R Administrators	114
Common Responsibilities of ID&R Administrators	114
Providing Training.....	121
Conclusion.....	129
Recruiter Checklist	129
Chapter 10. Planning ID&R Deployment and Supporting Recruiters	130
Planning Recruitment and Deploying Recruiters.....	130
Supporting Recruiters.....	131

Conclusion	136
Recruiter Checklist	137
Chapter 11. Quality Control in the ID&R System	138
Responsibility for Quality Control	138
Overview of Quality Control	138
Product-Oriented Quality Control	141
Quality Control in ID&R	142
Reviewing the COE	145
Resolving Eligibility Questions	148
Validating Child Eligibility	149
Monitoring Eligibility	154
Conclusion	158
Recruiter Checklist	158
Appendices	160
Appendix I: Legal Issues	161
Appendix II: Resources and Partnerships	172
Appendix III: Sample Surveys	179
Appendix IV: Sample Brochures	182
Appendix V: Sample Letters	191
Appendix VI: Sample Individual Action Plan	193
Appendix VII: Sample Recruiter Ethics Guidelines	196
Appendix VIII: Sample Interview Script	200
Appendix IX: New Recruiter Self Check	214
Appendix X: Describing Common Qualifying Work	224
Appendix XI: State-Provided Supplemental ID&R Materials	225
Appendix XII: COE Review Checklist	226
Appendix XIII: Records Exchange	227
Appendix XIV: Validating the ID&R System through Re-interviewing	231
Appendix XV: State ID&R Models	233
Appendix XVI: Chapter Checklists	248
Glossary	254

Figures

Figure 1. A Typical MEP Organizational Structure	7
Figure 2. The National Agricultural Statistics Service Website	32
Figure 3. The Migrant Education Program Logo.....	38
Figure 4. Basic Child Eligibility Factors Chart	78
Figure 5. Eligibility Question Chain of Command	81
Figure 6. Cost of Defects In Comparison to Time of Defect Detection	141
Figure 7. COE Review Flowchart.....	147
Figure 8. Steps in Validating Child Eligibility.....	150

Tables

Table 1. Eligibility Interviewing Assumptions and Facts	64
Table 2. Comparison of Open-Ended vs. Leading Questions	65

Abbreviations

AYP	Adequate Yearly Progress
BAM	Born After the Move
CAMP	College Assistance Migrant Program
COE	Certificate of Eligibility
CNA	Comprehensive Needs Assessment
CSPR	Consolidated State Performance Report
DES	Data Entry Specialist
ED	U.S. Department of Education
EDGAR	Education Department General Administrative Regulations
ELL	English Language Learner
ELP	English Language Proficient
ESL	English as a Second Language
EOE	End of Eligibility
ESEA	Elementary and Secondary Act of 1965, as amended
FERPA	Family Educational Rights and Privacy Act
GED	General Educational Development
HEP	High School Equivalency Program
HRSA	U.S. Department of Health, Resources and Services Administration
HSED	High School Equivalency Diploma
ICE	Immigration and Customs Enforcement
ID&R	Identification and Recruitment
INS	Immigration and Naturalization Service
LEA	Local Educational Agency
LOA	Local Operating Agency
MEP	Migrant Education Program
MOU	Memorandum of Understanding
NASDME	National Association of State Directors of Migrant Education
NASS	National Agricultural Statistics Service
NAWS	National Agricultural Workers Survey
NCLB	No Child Left Behind Act of 2001
NFJP	National Farmworker Jobs Program
OIG	Office of the Inspector General
OME	Office of Migrant Education
OSY	Out-of-School Youth
PAC	Parent Advisory Council
QAD	Qualifying Arrival Date
SDP	Service Delivery Plan
SEA	State Educational Agency
WIC	Women, Infants, and Children Program

Foreword

The Office of Migrant Education (OME) is pleased to introduce this *Migrant Education Program Identification and Recruitment Manual*—an essential resource for migrant educators nationwide. This publication is an integral part of OME’s Identification and Recruitment (ID&R) Initiative, which was established in 2000 to help states conduct timely and accurate identification and recruitment of eligible migrant children. Many substantive changes have occurred in the past decade; this manual includes detailed guidance on key revisions made to the program regulations in 2008. Through this initiative, OME (1) sustains a professional network of ID&R coordinators, (2) develops resources that help states strengthen their ID&R practices and quality control systems, (3) disseminates best practices for identifying and recruiting migrant children and determining their eligibility, and (4) provides up-to-date federal policy guidance on migrant child eligibility and ID&R issues.

Finding and enrolling eligible migrant children quickly and efficiently is the foundation of a strong Migrant Education Program (MEP). Migrant families often experience difficulty in receiving continuous high-quality educational services because of their high rate of mobility, cultural and language barriers, social isolation, health-related problems, disruption of their children’s education, and the lack of resources in the areas in which they live and work. Before migrant children can be served, however, they must be found and enrolled into the MEP without delay.

This publication provides guidance on how to recruit effectively and how to set up an efficient and accurate ID&R system. It highlights the many valuable “lessons learned” over time by states engaged in developing and improving their ID&R systems at all levels. One such innovation is the Migrant Student Information Exchange (MSIX), the electronic system of student records which allows states to safely collect and maintain migrant student records and share educational and health information on migrant children nationwide. Another key development in the world of migrant education has been the increasing challenge of identifying and serving a growing population of out-of-school youth (OSY). It is my hope that this comprehensive resource will help renew the commitment of all MEP recruitment staff to the timely and proper ID&R of eligible migrant children.

I appreciate the dedication and service of all who work each day on behalf of migrant children and their families. It is more crucial than ever that we use every available resource and innovative strategies to identify and serve the children of our hard-working migrant farm workers and fishers. I look forward to continuing our work together to strengthen this gateway to the provision of vital MEP services.

Lisa R. Ramirez, Ed.D.

Director

Office of Migrant Education

U.S. Department of Education

Washington, D.C.

Preface

Purpose

This Migrant Education Program Identification and Recruitment Manual (ID&R Manual) is designed to assist state educational agencies (SEAs) in developing state ID&R systems for the MEP, thereby correctly implementing the MEP statute and regulations. The SEA is responsible for the proper and timely ID&R of all eligible migrant children in the state, including documenting the reason why each child has been determined to be eligible for the MEP. Part I of this manual provides general information and advice regarding the *recruiter's* role in the ID&R process and in ensuring the correctness of eligibility determinations. Part II of this manual provides general information and advice regarding the state and/or regional *administrator's* role.

This manual is not intended to be prescriptive. *The examples provided in this document should not be viewed as the "only" or the "best" way to identify migrant children.* Instead, they are provided as tools to help practitioners consider the range of options available, and to stimulate thinking about this topic. This document is one of many resources for SEAs and local operating agencies (LOAs) to use as they determine how best to identify and recruit eligible migrant children in a manner consistent with the requirements of the Elementary and Secondary Education Act of 1965, as amended (ESEA). While users of this manual may wish to utilize or adapt the information presented here, they are free to develop their own approaches that are consistent with applicable federal statutes and regulations.

This manual is meant to be read in conjunction with the following companion documents:

- The authorizing statute
- The applicable regulations
- The 2010 Non-Regulatory Guidance for Title 1, Part C, Education of Migratory Children MEP (*Guidance*)
- The U.S. Department of Education's (ED) guidance on other Federal programs that are relevant to the MEP (such as Title I, Part A, and Title III)
- State requirements, policies, and guidance

The statute and regulations are binding on both ED and its grantees and cannot be changed outside of the reauthorization and regulatory processes. By comparison, policy guidance is not binding on grantees. Therefore, SEAS may adopt policies and procedures other than those found in the MEP's *Non-Regulatory Guidance* (*Guidance*) or this technical assistance manual, provided that they reflect reasonable interpretations of the MEP statute and ED regulations. Words in the guidance and this manual like "must" and "shall" are used to indicate statutory and regulatory requirements.

States are responsible for making decisions regarding the best way to operate the MEP consistent with federal and state regulations. It is critical that staff at the SEA and local level realize that they should not continue practices simply because they are based on longstanding policy, but rather should adjust to current needs, research and experience with what works.

This *Migrant Education Program Identification and Recruitment Manual* (ID&R Manual) is meant to provide general advice on ID&R.

Audience. The primary audience for this manual is SEA administrators. However, it should also be of interest to ID&R coordinators, ID&R contractors, regional administrators (the individuals who administer ID&R within each state), local administrators, recruiters, home-school liaisons, and migrant advocates. Part I of this manual explains the major duties and responsibilities of the recruiter. Part II discusses the administration of an ID&R system. Recruiters and administrators should read their own section of the manual as well as their counterpart's in order to understand the full scope of responsibilities. Although Part I and Part II can be read separately, reading both parts together helps to provide a more complete understanding of a MEP ID&R system.

Organization. This manual is organized as follows: Chapter, Section, Subsection, and Paragraph Header. Below is an example of how information is visually organized:

Chapter 1.

Section

Subsection. The recruiter is responsible for interviewing children, families, and youth to determine if they are eligible for the Migrant Education Program.

Paragraph Header. The recruiter is responsible for interviewing children, families, and youth to determine if they are eligible for the Migrant Education Program.

Style. This manual follows the conventions of The Associated Press Stylebook and The Chicago Manual of Style.

Background

No Child Left Behind. The No Child Left Behind Act of 2001 (NCLB) reauthorized the ESEA. A key purpose of the NCLB is to provide all children with the opportunity to obtain a high-quality education that will enable them to meet their state’s challenging academic content and achievement standards.

The Migrant Education Program. The MEP is authorized by Title I, Part C of the ESEA, as amended. Under the MEP, ED provides formula grants to SEAs to establish or improve education programs for migrant children. The general purpose of the MEP is to ensure that migrant children fully benefit from the same free public education provided to non-migrant children. To achieve this purpose, the MEP provides financial support to SEAs and LOAs to address the special educational needs of migrant children. In order to meet the goal of supporting the academic success of eligible migratory children, the MEP must first identify and recruit these children.

Primary Goal of the MEP. The primary goal of the MEP is to help ensure that all eligible migratory children meet challenging academic standards AND graduate with a high school diploma (or complete a GED) that prepares them for responsible citizenship, further learning, and productive employment.

ID&R Initiatives and Research. Since the MEP began in 1966, many states and educational organizations have produced publications that describe the ID&R process and provide useful suggestions and tools. Some of the most well-known national efforts include:

- 1981. The Migrant Education Recruitment and Identification Taskforce Project (MERIT) developed tools for ID&R, such as a national identification document and other training materials. ED provided funding for this effort through a grant awarded to the Indiana Department of Education under former section 143 of the ESEA.
- 1986. The Louisiana Department of Education published the Systemic Methodology for Accountability in Recruiter Training Manual (the SMART Manual). ED provided funding for this effort through a grant under former section 143 of the ESEA.
- 1989. The Pennsylvania MEP produced four ID&R publications: (1) a guide for recruiters, (2) a guide for administrators, (3) a reference supplement, and (4) a research report entitled *The Effects of Migration on Children: An Ethnographic Study*. ED provided funding for this effort through a grant under the former section 143 of the ESEA.

How to Use the Manual

Language. Although ease of reading and clarity were important in the development of this manual, the text may present some difficulties, particularly for those who speak English as their second language (ESL). Because this is a technical manual, the language has not been modified; however, language accessibility has been taken into consideration in developing the ID&R Curriculum which supplements this manual.

Recruiter and Administrator Checklists. Checklists that cover key points have been provided at the end of each chapter and as a consolidated document in Appendix XVI. The purpose of the checklists is to provide an organizational tool to help the reader review the key concepts presented in each chapter and to think about the action steps that are required to implement each concept.

Lessons Learned. In recognition of the experience of the ID&R community, OME has interspersed “lessons learned” from veteran ID&R staff throughout the manual. Lessons learned reflect advice regarding both strategies to adopt and pitfalls to avoid. These lessons learned help new and veteran recruiters benefit from the experience of others.

Tips from MEP Staff. Throughout the manual, the reader will see quotations that are indented and italicized. These quotations are often tips, pieces of advice, or “good ideas” from MEP practitioners. Some are taken from state and past federal manuals, which are referenced. Others represent powerful ideas heard from recruiters and administrators at meetings and forums. In some cases, the wording has been changed to make the idea clearer.

Children and Youth. For purposes of this manual, the term “child” refers to any individual who is below the age of 22 as defined in section 1115(b)(1)(A) of the ESEA (which is an MEP requirement by virtue of section 1304(c)(2) of the ESEA). However, readers should be aware that this term includes children, youth, and perhaps even young adults.

Recruiter. For purposes of this manual, the term “recruiter” refers to any individual who gathers facts for a determination of a child’s eligibility for the MEP.

PART I:

The Recruiter Manual

Chapter 1. Background and Overview of the Migrant Education Program

Children of Migratory Farmworkers and Fishers

Pedro is in his second school this academic year; his family moved from Texas to Michigan to harvest cherries.

Nancy was a freshman in high school last year, but now she has left school to pick apples with her father.

Thelma dreams of being a nurse someday, but knows she'll never have enough credits to graduate from high school because her family keeps moving back and forth from California to Oregon.

These are the children of America's migratory workers, and their education suffers as a consequence of their family's mobile way of life. The purpose of the MEP is to locate these children, determine whether they are eligible for the program, and, if so, provide them with the supplemental instructional and support services they need to succeed in school.

Our nation's economy depends upon workers who perform a variety of temporary and seasonal jobs that help produce, harvest, and process crops, livestock, poultry, fish, shellfish, dairy, and other agricultural products. The workers who fill these jobs are often forced to piece together a number of agricultural or fishing jobs to make a living that will sustain them and their families throughout the year. These jobs are often located far from one another, requiring the worker to move and reside temporarily in an area near the work. Due to economic necessity, many workers and their families migrate back and forth from a home base¹ to locations where they can obtain one or more of these temporary or seasonal jobs. The workers who move in search of such work are known as "migrant" agricultural workers or fishers.

Migrant agricultural workers and fishers share a number of common characteristics that pose significant challenges in their lives:

- They repeatedly relocate for work due to economic necessity.
- They are often isolated from services.
- They are "working poor" as a result of the low wages they are paid for their labor.
- They often reside in sub-standard living conditions.
- They frequently have low levels of education.

¹ Many migrant families have a *home base* or hometown where they live for much of the year. They travel or migrate from this home base to other places to work.

- They are subject to inadequate or non-existent health care.
- They often feel isolated from the larger community because they come from a different culture and frequently speak a language other than English (some speak indigenous languages, making it difficult to find interpreters and translated materials).
- They often move to and from other countries (especially Mexico).
- Many live in fear due to documentation and legal status issues.
- These characteristics and life experiences create special educational circumstances for the children of migrant workers and young migrant workers who move regularly.
- Migration means changing schools, teachers, and curricula, and often chronic absenteeism for school-age children. Changing schools diminishes a student's sense of belonging and makes it more difficult to participate in the classroom and extracurricular activities.
- Children of migrant workers often have limited opportunities to learn the English language because their parents may not be proficient in English. Furthermore, children who spend part of the year in countries (and schools) in which English is not commonly spoken do not have as much opportunity to learn and practice English.
- Migrant parents' low levels of education and socioeconomic status often limit the amount and quality of educational support that can be offered in the home.
- Health insurance and wages that ensure adequate access to health care for young children and adolescents are not generally provided by temporary and seasonal jobs in agriculture and fishing.
- Because they are temporary residents, migrant workers and their children are often treated like outsiders and may face discrimination. This fact may limit their access to services to which they are entitled.
- Schools and states may not have much incentive to provide high-quality services to the most mobile migrant students. For example, while schools are required to test every migrant child who is enrolled in the school during the testing dates, they are not required to aggregate the test scores of migrant children as a separate subgroup.
- Students may not receive academic credit for courses they have completed when states do not have an active system for granting and transferring course credits earned within the state, or accepting course credits earned in other states.

Migrant children are known to be at high risk of school failure due to these characteristics and experiences. The special educational needs that arise from the migrant life and the challenges our nation's schools face in effectively educating a highly mobile and disadvantaged population keep that risk high.

Migrant out-of-school youth (OSY) who work in agriculture or fishing rather than attending school are at an even greater risk of failing to obtain the level of education required to succeed in life. These

OSY may travel with families, an older relative or crew chief, in small groups, or alone. As demographic patterns in the MEP shift away from the migration of families toward the migration of single males and females, migration patterns change. To date, OSY have become the fastest growing population of MEP students. OSY face all the obstacles to education encountered by other migrant students, plus additional challenges.² OSY are seldom connected with the community in which they live and as a result, the MEP may be their only link to education, support, and the medical services they need.

Purpose of the Migrant Education Program

In 1966, the U.S. Congress amended Title I of the ESEA to include a new section: Part C—Education of Migratory Children. Through this amendment Congress authorized, for the first time, a program that provided states with federal financial assistance to help improve the educational opportunities and academic success for the children of migratory agricultural workers. This program was called the Migrant Education Program, or MEP.

The ESEA, as amended, states that the purpose of the MEP is to:

- Support high-quality and comprehensive educational programs for migrant children to help reduce the educational disruption and other problems that result from repeated moves.
- Ensure that migrant children who move among the states are not penalized in any manner by disparities among the states in curriculum, graduation requirements, state academic content, and student academic achievement standards.
- Ensure that migrant children are provided with the appropriate educational services (including supportive services) that address their special needs in a coordinated and efficient manner.
- Ensure that migrant children receive full and appropriate opportunities to meet the same challenging state academic content and student academic achievement standards that all children are expected to meet.
- Design programs to help migrant children overcome educational disruption, cultural and language barriers, social isolation, various health-related problems, and other factors that inhibit the ability of such children to do well in school and to prepare such children to make a successful transition to post-secondary education or employment.
- Ensure that migrant children benefit from state and local systemic reforms.

The principal operational goal of the MEP is to ensure that all migrant students meet challenging academic standards so that they graduate with a high school diploma or receive a General Equivalency Diploma (GED) or High School Equivalency Diploma (HSED) that prepares them for responsible citizenship, further learning, and productive employment.

² <http://RESULTS.ed.gov>

Who is Eligible for the MEP?

The MEP was designed to help migrant children find success through education. Preparing a preschooler for kindergarten, helping a student learn to read or enhancing their English language proficiency, ensuring a child's promotion to the next grade, and helping a high school student earn credits toward graduation are just a few examples of activities that the MEP supports. However, before the MEP can provide any services, migrant education staff must determine that a child is eligible for the MEP. To understand migrant child eligibility, it is important to review the law.

According to sections 1115(b)(1)(A) (incorporated into the MEP program by virtue of sections 1304(c)(2)) and 1309(2) of the ESEA and § 200.81(e) and §§200.103(a) of ED's Title I regulations³, a child is a "migratory child" and is eligible for MEP services if all of the following conditions are met:

- The child is not older than 21 years of age; and
- The child is entitled to a free public education (through grade 12) under state law or is below the age of compulsory school attendance; and
- The child is a migratory agricultural worker or a migratory fisher or the child has a parent, spouse, or guardian who is a migratory agricultural worker or a migratory fisher; and
- The child moved within the preceding 36 months in order to seek or obtain qualifying work or to accompany or join the migratory agricultural worker or migratory fisher identified in paragraph three in order to seek or obtain qualifying work; and
- With regard to the move identified in paragraph four, the child:
 - Has moved from one school district to another; or
 - In a state that is comprised of a single school district, has moved from one administrative area to another within such district; or
 - Resides in a school district of more than 15,000 square miles and migrates a distance of 20 miles or more to a temporary residence to engage in a fishing activity or to accompany or join a parent, spouse, or guardian who engages in a fishing activity. (This provision currently applies only to Alaska.)

Note that the terms "migratory agricultural worker," "migratory fisher," "move or moved," "in order to obtain," and "qualifying work" are defined in § 200.81 of the regulations.

Children who fit this definition are eligible for MEP services. However, only those children who are between the ages of three and 22 (i.e., have not had a 22nd birthday) are counted for state funding purposes.

³ Chapter 34, Code of Federal Regulations, sections 200.81(e) and 200.103(a) (34 C.F.R. §§ 200.81(e) and 200.103(a)).

The Importance of ID&R in Determining Eligibility for the MEP

Working for the MEP means knowing you are affecting the lives of the most disadvantaged of our nation's children. Without the MEP, no one would be looking out for these precious children.

Identification means actively looking for and finding migrant children and youth. *Recruitment* means making contact with the family or youth and obtaining the necessary information to document the student's eligibility and enroll them into the MEP.

The ID&R of migrant children is essential because the SEA must create a record of eligibility for each migrant child before he or she can receive any of the MEP's educational or supportive services. The longer it takes a state to find a migrant child, the more time passes before the child receives the extra services he or she needs to succeed. Furthermore, the children who are most in need of MEP services are often the most difficult to find. Migrant children who are not identified may experience problems such as delays in placement or incorrect school assignment; failure to count partial credits or inappropriate course sequence for graduation from the student's home-based school; and obstacles to receiving necessary supplemental services. Even if an individual migrant child does not receive direct services, it is important to identify all migrant children so their needs can be assessed and monitored to plan future services if a need does arise.

Effective ID&R is a challenge for the MEP. The *proper* and *timely* ID&R of migrant children may be a difficult task for a number of reasons:

- Not all temporary or seasonal workers are eligible for the MEP because the worker must have moved in order to obtain qualifying work. Nor is everyone who moves to secure agricultural employment eligible for the MEP because, under the MEP, the move from one residence to another (see eligibility condition 5 discussed in the previous section) must occur due to economic necessity for the family or youth. The eligibility requirements for the MEP require strong analytical skills to properly evaluate eligibility.
- Migrant families are inclined to be self-sufficient and are not accustomed to seeking help outside of their own circle of family and friends.
- Children of migratory workers are often invisible, quietly coming and going, and not attracting much attention in a new community. If these children are not actively recruited, many would not be in school (they may accompany their parents to work or be left alone at home) or receive services from the MEP.
- Finding and recruiting many OSY who travel without their families or in groups of OSY is especially challenging. The traditional in-school recruitment model is not feasible because this population has no contact with the school district. Recruitment of OSY is most successful when it occurs at work sites, in the field, and at businesses where these youth work, as well as in housing where they live.
- Migrant families often do not speak or read English or are English language learners (ELLs), and some are not literate in their native language.

- Frequently, there are significant cultural barriers and misunderstandings between the migrant family and the community in which they reside.
- The places where migrant families work and reside are often located in remote areas, and employers may be uncomfortable if their employees have outside visitors during the workday. Employers may also discourage outside visitors because of concerns about liability, productivity, or the legality of their workers.
- There is considerable turnover in migrant agricultural and fishing work. The work is often difficult, dangerous, and, under the best circumstances, results in only modest wages. Living conditions in farmworker camps and other temporary, poorly maintained housing can be hard on all of the family members. Yet, while many migrant workers move into easier and more stable employment, others remain in or re-enter the migrant labor pool because they view the temporary or seasonal work in agriculture or fishing as their only employment option in the workforce.
- The MEP may not be able to serve all migrant children; the children may not currently need supplemental academic help or they may not be deemed a priority for service. Therefore, some families may not see an immediate benefit to their child being identified and may forgo the process.

For these and other reasons, the MEP needs to employ trained staff to identify and recruit migrant children. These staff members are usually called “recruiters” and they receive extensive training in a basic set of procedures on how to find and recruit migrant children for the MEP.

Organization of the MEP

There are many state MEP organizational structures. An example of an MEP structure is found below in Figure 1. While the MEP is administered by a single office (OME) within ED, organizational structures below the Federal level differ from state to state. Throughout the country, staff work on the MEP at the local, state and federal levels.

Figure 1. A Typical MEP Organizational Structure

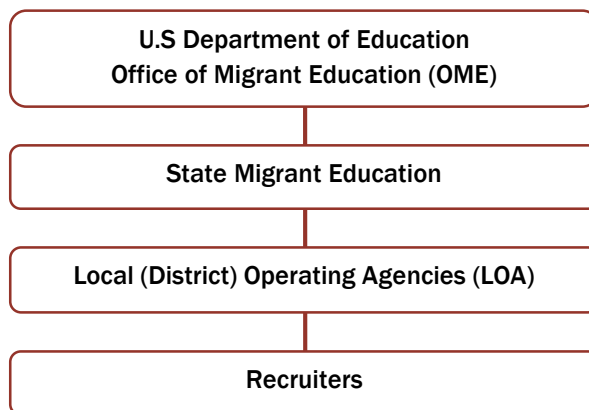

Role of Federal MEP Staff. At the federal level, OME administers the MEP nationally and provides guidance and support to SEAs that receive grants. The OME has several responsibilities, including providing national leadership, conducting special initiatives, helping ED to calculate state MEP allocations, monitoring state programs for compliance with federal requirements, collecting and analyzing student performance data, developing regulations and guidance, and providing technical assistance on how to implement the MEP. A federal program officer (i.e., contact person) is assigned to each state to assist and monitor its implementation of the MEP.

The OME has developed Guidance, a policy document that is written in an easy-to-follow question-and-answer format to help SEAs and LOAs understand the requirements that apply to the MEP and to suggest ways to implement them. As statutory or regulatory requirements change, OME updates the Guidance to help clarify the policies as they relate to the MEP. Recruiters are strongly encouraged to study the Chapters II and III of the Guidance on “Identification and Recruitment” and “Child Eligibility.” The Guidance is available in the Policy Guidance section of OME website at: <http://www2.ed.gov/programs/mep/legislation.html#guidance>.

Role of State MEP Staff. ED awards MEP formula grants to SEAs, which are solely responsible for the operation and administration of the program; most SEAs subgrant a portion of their MEP grant to LOAs, which help SEAs administer and operate the program. At the state level, most states have a MEP director who is responsible for overseeing all aspects of the administration of the program, including the state’s ID&R system. The MEP director may also have program responsibilities for other federal programs. The focus of the state director is to provide overall leadership and direction for the state as a whole, and to ensure that local programs comply with all applicable laws and other requirements. The state is responsible for finding and enrolling migrant children from across the state, for determining their unique needs, and for developing a service delivery plan that uses resources in an equitable and effective manner. Most states also have ID&R coordinators who provide statewide leadership and guidance to recruiters. When a recruiter asks a question that cannot be answered at the local level, the recruiter should raise the question at the state level for a response. It is important to recognize that each state has its own policies and procedures regarding chain-of-command and how to address questions and concerns. The recruiter should check with an immediate supervisor to learn the protocols in his or her state.

Role of Local MEP Staff. At the LOA level, the emphasis is on finding and serving individual migrant children. The recruiter, perhaps with assistance from other local staff, finds migrant children, determines whether they are eligible for the MEP, and helps connect them with appropriate services. Once the child is identified and the child’s needs are assessed, migrant educators and others at the district level may provide extra services that are beyond those offered by the local school. For example, MEP teachers and tutors may provide in-home tutoring, after school coursework, or summer programs. Migrant children may also be eligible to receive services through other programs serving migratory students, such as:

- The High School Equivalency Program (HEP), under which ED provides competitive grants to colleges, universities and non-profit organizations to help migrant and seasonal farmworkers and their immediate family members who are 16 years of age

or older to obtain a GED certificate or equivalent to gain employment, enter postsecondary education, or the military.

- The College Assistance Migrant Program (CAMP), under which ED provides competitive grants help migrant and seasonal farmworkers and their immediate family members complete their first undergraduate year of study in a college or university.

Local school districts that receive a subgrant from the SEA to serve migrant children are responsible to the state MEP. When a recruiter or anyone else at the local level has a question or needs support, the recruiter should turn to an immediate supervisor for assistance. The supervisor may be an ID&R staff member or a local program coordinator who has broader duties. Local projects are often asked to gather local data for the state for evaluation purposes and also to inform state decision makers.

I used to think that every state did things the same way. Then I went to a National ID&R Forum, where I learned that states have the flexibility to develop their own policies and procedures as long as they are consistent with the law and regulations.

Conclusion

The MEP helps meet the academic needs of an important and often overlooked sector of our society: migrant children. If it were not for the efforts of the MEP at the local, state, and federal levels, migrant children might remain invisible. In many cases, migrant children would not be identified or served if MEPs did not employ a network of recruiters to find and enroll them into the program. Without a record of eligibility, these children would not be able to receive the additional services they need to be successful. There are many layers of support at the local, state and federal levels of the MEP, so the recruiter should never feel that he or she is alone.

Recruiter Checklist

Chapter 1: Background and Overview of the MEP

Did you?

- Review the common characteristics of migrant agricultural workers and fishers?
- Familiarize yourself with the purpose of the MEP?
- Understand who is eligible to be recruited into the MEP?
- See why it is important to find migrant children?
- Understand how the MEP is organized?
- Recognize how important the recruiter is to the ID&R process?

Chapter 2. The MEP Recruiter

Recruitment Duties and Responsibilities

A good recruiter is determined more by his or her aptitude and attitude toward performing the unique responsibilities of the job than by any formal educational process.

Recruiters are very important because they often serve as the first contact between a migrant family or youth and the local school district, as well as the community at large. Also, for OSY, the recruiter may be the first direct contact with someone outside of their work crew. The initial contact is crucial because it provides the recruiter with the opportunity to determine whether the child may be eligible for the MEP. During this visit, the recruiter also sets the tone for the home-school relationship. It is the responsibility of the recruiter to be helpful without allowing the family or youth to become overly dependent on his/her assistance. The recruiter is often considered an ambassador in the eyes of migrant parents, the school district, agricultural employers, and the community. For example, a bilingual recruiter may be instrumental in explaining important school policies to a migrant family and may be an important connection for an OSY to educational and social service opportunities. In this way, the recruiter is the main link between the migrant family or youth and the MEP and other resources.

The recruiter's primary job is to find and enroll eligible migrant children into the MEP. Locating migrant children can be hard work, and the recruiter must become skilled at performing a range of duties and adapting to situations to be successful. While recruiting migrant children is the recruiter's primary responsibility, he or she also often plays an important role in helping to ensure that these children receive vital educational and social services. Thus, while "recruiter" is the most commonly used term to describe this staff position, other terms used include:

- Advocate
- Home visitor
- Recruitment specialist
- Interviewer
- School liaison
- Community liaison
- Outreach worker

The MEP recruiter's primary responsibilities include the following:

- Learning the MEP eligibility requirements.
- Establishing and maintaining a recruitment network.¹
- Determining where migrant families and youth live and work.
- Finding migrant children and their families and youth.
- Explaining the MEP to migrant families and youth.

¹ A recruitment network is a system of contacts, including individuals, agencies, and other institutions, that provide information on how to identify and locate potentially eligible children.

- Interviewing the family or youth.
- Making preliminary determinations on the eligibility of the child or youth.
- Completing the Certificate of Eligibility (COE).
- Implementing state quality control procedures.
- Following ethical standards and confidentiality laws
- Facilitating communication among migrant families, schools, agricultural employers, and the community

The recruiter often has job responsibilities beyond ID&R. For example, the recruiter may help migrant families navigate the unfamiliar, and sometimes unfriendly, environment that families might encounter in a new community. As mentioned previously, the recruiter may also work as an advocate, translator, home-school liaison, or parent involvement coordinator.

Characteristics of a Successful Recruiter

Great recruiters are made, not born. If a recruiter doesn't feel ready to do the job, the recruiter should work with a supervisor to identify and develop the skills needed to be successful.

Experienced ID&R Coordinators say that, as a general rule, it takes about three years for a recruiter to fully learn the job. The specific skills required to be a great recruiter are developed over time using strategies such as those described in Chapter 3. If the recruiter does not initially possess these skills, the supervisor can help the recruiter cultivate them.

When ID&R coordinators and MEP administrators are asked about “a great recruiter” or “their best recruiter,” certain characteristics emerge. A great recruiter is able to:

- Make correct eligibility decisions.
- Document child eligibility accurately and clearly.
- Manage time wisely.
- Work independently.
- Remain flexible and adapt to a constantly changing environment.
- Relate well to others and gain their trust.
- Create positive relationships with agricultural employers.
- Use effective interviewing (i.e., questioning) skills.
- Maintain appropriate relationship boundaries.
- Follow confidentiality laws.
- Demonstrate personal integrity.
- Speak local migrant families' native language and exhibit cultural sensitivity.

Few recruiters come to the job with all of the skills that make a great recruiter. Effort, enthusiasm, and a willingness to learn are necessary. Although it may take a number of years to be considered great, it is within the grasp of every recruiter to achieve excellence.

Lessons Learned: Recruiter Roles & Responsibilities

Each recruiter has stories about things that went wrong or that could have been done differently in carrying out his or her roles and responsibilities. These lessons learned may help the new recruiter avoid pitfalls that experienced recruiters have faced.

Know About the Local MEP. The recruiter must know more than just recruitment. As stated earlier, the recruiter is often the face of the MEP to families, OSY, schools, and the local community. A recruiter is also a champion for the MEP. A migrant family will often ask the recruiter questions about MEP services that the school and other programs offer such as: does the MEP offer a pre-school program, is there a summer school, are dropouts eligible for the MEP, and what programs are available to help my son/daughter graduate? The recruiter should learn about the MEP and other school and community programs that migrant children and families are eligible to receive.

Develop A Recruitment Network. A recruitment network is a system of contacts, including individuals, agencies, and other institutions, that provide information on how to identify and locate potentially eligible children. Establishing a recruitment network and developing a strong working relationship with each member of that network is an important way of finding migrant children who may be eligible for MEP services. When done properly, a recruitment network can serve as the eyes and ears of the recruiter. Key sources of information include employers, schools, community-based agencies, commercial establishments, and others. The recruitment network is further explained in Chapters 4 and 5.

Determine Work Priorities. The recruiter often has many roles. If the recruiter is expected to recruit and do other work for the MEP, the recruiter should determine the work the supervisor considers the highest priority and allocate time accordingly. For example, the recruiter, with guidance from the supervisor, may need to decide which of the following activities would be most productive: attending a job fair to recruit, staying in the school's main office to meet new families that may be eligible for the MEP, knocking on doors to canvass for new families, or translating at the MEP after-school program. In order to prioritize, the recruiter will need to assess which of these activities provide the greatest benefit to the MEP.

Give the MEP Its Due. If a recruiter is paid by more than one funding source, the recruiter should ask an immediate supervisor how much of his or her time is paid from MEP funds and how many hours per week should be spent on ID&R activities. The recruiter should then devote that amount of time to MEP work. If the school asks the recruiter to spend MEP time on work that does not directly benefit the MEP (e.g., playground or lunchroom duty or translating for non-migrant parents), the recruiter should respectfully decline. If the school insists that the recruiter spend MEP-funded time on non-MEP work, the recruiter should contact a supervisor. Similarly, a recruiter who works full-time for the MEP should guard his or her time to make sure all work activities benefit the MEP.

Ask Questions. There are many people who work in the MEP who are willing to help the recruiter do the job correctly. If the recruiter has a question or does not understand how something should be done, the recruiter should ask someone who is knowledgeable and write down the answer. In this way, the recruiter will become increasingly knowledgeable over time.

Make Ethical Decisions. The recruiter will meet families and youth who have great needs. The recruiter may believe that those children need and deserve help, even if they do not qualify for the MEP. On the other hand, the recruiter may meet families whose children clearly qualify for the MEP, but may not find them as deserving. Because of these feelings, the recruiter may experience internal conflict about making accurate eligibility decisions. Each recruiter brings a set of personal beliefs and biases to the job; the recruiter will need to put these personal feelings aside in order to make objective decisions based on the MEP eligibility criteria.

Maintain Appropriate Relationship Boundaries. The needs of migrant families can be overwhelming to a recruiter. However, it is important for a recruiter not to make promises that cannot be kept. The recruiter should exercise caution in assisting needy families and youth with non-educationally related needs. Good judgment and tact must be used in deciding when and for how long to help a family. For example, a migrant family that has recently arrived from another country is often more dependent on the recruiter's guidance, assistance, and support than a family who has spent more time in the U.S. The bilingual recruiter may be the only one who can make a school appointment for a family, help the family resolve an unpaid medical bill, or direct the family to other services in the community. However, there is a fine line between providing support to a family and hindering the family's ability to become self-reliant. The recruiter should learn when it is appropriate to help a family and when to refer them to other local services. The best service a recruiter can provide migrant families or youth is to help them develop skills in order for them to become increasingly independent.

Be Aware of Federal, State and Local Requirements. States and LOAs may have their own requirements for the recruiter that go beyond the federal requirements. For example, if the vast majority of migrant families are of Mexican origin, a state may require the recruiter to know Spanish and demonstrate sensitivity to the various cultures of Mexico. Other state-specific requirements may include responsibility for knowing and understanding privacy laws and reporting suspected cases of child abuse or child abduction. Recruiters also need to become familiar with The Family Educational Rights and Privacy Act (FERPA), the federal law that protects the privacy of student education records from unauthorized release.² While these areas should be part of every recruiter's training, if the recruiter is not aware of FERPA or the applicable state privacy, child abuse or other relevant laws, the recruiter should ask a supervisor.

Volunteers Expand Services. A well-established volunteer network can provide recruiters with resources outside of the realm of MEP funding and can be called into action when a recruiter is feeling overwhelmed with service requests. Despite assumptions to the contrary, many people are interested in assisting the migrant community—churches, students at institutions of higher learning, retirees, community members, and various coalitions frequently seek a fulfilling volunteer

² The Family Educational Rights and Privacy Act (20 U.S.C. § 1232g; 34 CFR Part 99)

experience. A recruiter's impact can increase exponentially when working in collaboration with a strong volunteer network.

Remember That a Recruiter Is Not Alone. Being a recruiter can sometimes seem like a lonely job. However, ID&R is a team effort. It is important for the recruiter to understand that identifying, recruiting, and determining the eligibility of migrant children is the mutual responsibility of the recruiter and the ID&R team. When the recruiter has questions or needs help, there are other people who work in the MEP at the local, state, and federal levels who can assist. For example, local program staff may be able to provide leads on children who may be eligible for the MEP, a recruitment supervisor may help in planning recruitment strategies, and state staff may be able to assist in resolving eligibility questions. Spending a day in the field shadowing a fellow recruiter can also be beneficial to learn new recruiting techniques and get a different perspective from another person who understands the challenges facing recruiters.

Conclusion

Reaching migrant children and youth is at the heart of the MEP, and the importance of effective recruitment cannot be overemphasized. Without a good recruiter, the neediest migrant children may not be served. The effective recruiter can become the center of a network that connects migrant families and youth to schools and communities. When migrant families trust the recruiter, they are much more likely to tell him or her when new migrant families move into an area. When growers and other employers trust the recruiter, they are more likely to allow recruitment at the employment site and to support the MEP. Recognizing the value of these networks is the beginning of great recruiting. Chapter 3 will discuss how the recruiter learns the job.

Recruiter Checklist

Chapter 2: The MEP Recruiter

Did you?

- Identify the characteristics of a successful recruiter?
- Familiarize yourself with the recruiter's basic duties and responsibilities?
- Think about how personal emotions can affect the recruiter's behavior toward needy families and youth?
- Think about how important it is to know what services your local migrant education program provides?
- Understand that recruitment is a team effort?

Chapter 3. Learning to Recruit

Learning about Identification and Recruitment

To successfully find migrant children, the recruiter must have a clear idea of who to look for and the best strategies for finding them. Training both novice and veteran recruiters can be compared to teaching someone to drive a car. Just as a driver education instructor would not put a new student driver behind the wheel of a car on a busy road those who administer the MEP at a state or local level should not send a new recruiter out to find and interview migrant families or youth without proper instruction and guided practice. Similarly, veteran recruiters, like veteran drivers, may need a defensive driving course once in a while to refresh their knowledge and skills.

The process that a new driver goes through to learn the “rules of the road” is similar to the process that a new recruiter goes through to learn the basic MEP child eligibility requirements. Learning the rules of the road generally involves both classroom instruction and independent study, as does learning basic MEP eligibility definitions. Likewise, the guided practice that a new driver receives with the help of a driver education instructor or parent is similar to what the new recruiter should receive under a knowledgeable and experienced recruitment mentor. Finally, before a new driver may operate a car alone, he or she must pass a driver’s test. Along the same lines, the new recruiter should demonstrate proficiency in recruiting eligible children before being allowed to work independently. Some states require the new recruiter to take a certification examination or survey that measures the recruiter’s ability to make correct eligibility determinations.

Furthermore, , state and local personnel should not assume that veteran recruiters do not need continual training and development. As in some states, where drivers may have to take a vision test or a road test to renew their license, veteran recruiters will need to retrain and relearn as laws and regulations change. Beyond new laws and regulatory changes, veteran recruiters should seek out at least one professional development opportunity a year to enhance skills and knowledge.

The recruiter and an immediate supervisor should work together to build and maintain the recruiter’s knowledge and skills. This chapter will discuss the general knowledge and skills of ID&R, the types of training a recruiter might receive, and other strategies to help the recruiter learn, or relearn, the job of ID&R.

Knowledge and Skills of Identification and Recruitment

OME has developed a National ID&R Curriculum that identifies the core knowledge and skills that it believes a recruiter needs to master in order to properly identify and recruit migrant children and make preliminary eligibility determinations.

The National ID&R Curriculum consists of eight modules, each based on one or more chapters of the National ID&R Manual. The content of each module is taught through research-based instructional strategies designed to meet the needs of all learners. Participants will use the four modalities of

recruiting (reading, writing, listening, and speaking) to process the content being delivered, and the trainer will facilitate the learning process by actively monitoring, questioning, and clarifying, when needed.

Each module consists of 1-3 levels designed to allow the trainer the option of selecting specific topics to train based on the composition of the audience. Level 1 will provide the basic information for the module topic, which makes it ideal for new recruiters and/or migrant staff members, or to use as a refresher for veteran recruiters. Subsequent levels provide additional topics of study related to the module, which make them ideal for follow-up or in-depth trainings.

The ID&R curriculum was created to transform this ID&R Manual's set of knowledge and skills into a training experience¹. The curriculum is based on the following five objectives:

1. State and local MEP recruiters understand the background of the MEP, the ID&R process of the MEP, and the duties and responsibilities of a recruiter. As indicated by the first objective, the recruiter will learn about the purpose, basic history, and organization of the MEP. In addition, the recruiter will learn the basic eligibility requirements and the general process for ID&R. Finally, the recruiter will become aware of his or her basic duties and responsibilities.
2. State and local MEP personnel implement practices that result in the efficient ID&R of migrant children. To satisfy the second objective, the recruiter will learn how to develop a recruitment network, how to determine where migrant families and youth live and work, and how to locate them. The recruiter will also learn to understand and respect the diversity of migrant children, youth, and their families in order to interact with them effectively. The recruiter will practice how to explain the MEP to migrant families and youth and will learn how to organize and manage his or her caseload. Finally, the recruiter will learn how to take appropriate precautions to ensure personal safety.
3. State and local MEP personnel implement practices that result in reliable and valid child eligibility determinations. For this third objective, the recruiter will master the child eligibility requirements under the MEP. The recruiter will also demonstrate the knowledge and skills needed to effectively interview a family or youth. The recruiter will learn to make valid and reliable preliminary child eligibility determinations and to implement quality control activities.
4. State and local MEP personnel are aware of and adhere to ethical standards of behavior in child eligibility determinations. The recruiter will practice ethical behavior when determining a child's eligibility.
5. State and local MEP personnel implement practices that strengthen coordination and collaboration between migrant families, school(s), and the community. The recruiter will demonstrate the ability to facilitate coordination and collaboration between migrant families, school(s), and the community. The recruiter will practice meeting planning, facilitation, and team building.

¹ National Identification and Recruitment Training Curriculum, U.S. Department of Education, Office of Migrant Education (April 2012).

States may want to consider developing their own ID&R training programs that are customized to the specific needs and characteristics of their states. For example, the recruiter should know about the local MEP including services offered, dates of operation, hours, and contact information. Here are some other topics that state and local training programs should consider including:

- How the state and local ID&R system is organized, including reporting relationships
- State & local ID&R policies and procedures, including required paperwork
- The content of the state and local ID&R plans, when available
- Demographic information regarding the characteristics of local migratory agricultural workers and fishers and their children, as well as their mobility patterns
- State methods of collecting and maintaining data on migrant children
- The recruiter's role in the state's quality control process and how to assist in developing and implementing the state or local plan for quality control, such as the mandatory federal re-interviewing requirements
- The organizations with which the state and local education agencies expect the recruiter to coordinate and the amount of time the recruiter should allocate to this coordination

The National ID&R Curriculum provides a structure that can be used to teach the newest recruiter the basic knowledge and skills needed to properly identify and recruit migrant children. It can also provide the most veteran recruiter with an understanding of more advanced recruitment concepts that prepares them for a stronger leadership role in the MEP. In combination with the National ID&R Curriculum, individual state ID&R orientation, on-going training, and this ID&R Manual, recruiters will discover the wide range of knowledge and skills necessary to become an effective MEP recruiter. States should continually work to improve their overall ID&R system and sharpen the knowledge and skills of new and veteran recruiters alike.

New Recruiter Training

The new recruiter generally receives basic training from an ID&R coordinator, a state-approved trainer, a local program coordinator, and/or a highly knowledgeable and skilled recruiter. This training often starts in a classroom or one-on-one setting and is generally followed by independent study and on-the-job training in the field. The on-the-job training often pairs the new recruiter with a highly skilled staff member until the new recruiter is ready to recruit or conduct an interview alone.

Classroom or Individual Training. By the end of the basic training, the recruiter should be able to correctly answer questions such as:

- Why are migrant children identified and recruited? See Chapter 1.
- Who is eligible for the MEP? See Chapter 6.
- How do I find eligible children and youth? How do I develop an ID&R action plan? See Chapters 4, 5, and Appendix II.

- How do I conduct an interview? How do I explain the MEP to the family? What local services are available? See Chapter 6.
- How do I determine if a particular child is eligible for the MEP? See Chapter 7.
- What do I do if I encounter a situation that is not covered in the Sample Interview Script? See Chapter 7.
- How do I fill out a COE? See Chapter 8.
- How is my state's student eligibility data collected, used, and stored? See Chapter 8.
- What ethical standards should I follow? See Chapters 2, 6, 7, and 8.
- What should I know about the language and culture of migrant families in my area? See Chapter 1.
- What safety precautions should I take when recruiting? See Chapter 5.
- What state and local laws should I know about? See state ID&R material.

After the classroom or individual training ends, the new recruiter should work with a supervisor to explore what other federal, state, and local training materials and opportunities are available, and use this information to develop a long-term personal training and development plan. SEAs and LOAs generally offer training on the MEP that recruiters are required to attend and SEAs also hold an annual national conference that features workshops with updated ID&R information and methods held every year. Even though not all recruiters may be able to attend a national MEP conference, the state and local staff generally obtain and disseminate information from the conference.

Independent Study. In addition to taking the basic classroom training, the recruiter should study key documents on his or her own. In particular, the new recruiter is encouraged to study the materials provided in the initial training, use the National ID&R Curriculum as a way to gauge progress in learning the suggested knowledge and skills, self-check learning through the use of Chapter Checklists provided in this manual, and carefully read and study relevant documents such as:

- The law and regulations (including the instructions to complete the National COE)
- The MEP Guidance, which is available online at <http://www2.ed.gov/programs/mep/legislation.html#guidance>
- This ID&R Manual
- State ID&R materials (if available)
- The state's Comprehensive Needs Assessment (CNA) and Comprehensive State Plan (also known as the Service Delivery Plan or SDP)
- Applicable state and local laws, regulations, and policy guidance
- Relevant state and local ID&R action plans (more information will be provided in Chapter 5)
- The RESULTS website at <http://RESULTS.ed.gov>

The goal of independent study is for the new recruiter to become familiar with these key documents and to know where to find answers to basic questions about ID&R and child eligibility. It is critical for the recruiter to stay up-to-date on the latest changes in guidance and policy at both the state and federal levels.

If you're a new recruiter, find a good, experienced recruiter and ask if you can tag along when he or she makes home visits. After a few visits, attempt your first MEP introduction or conduct a parent interview. You'll learn far more seeing it done and doing it than you will just talking about it or reading an ID&R manual. You might try this even if you are not a new recruiter. The really great recruiter is always trying to learn new things.

Field-Based Training. Many states try to match new recruiters with mentors who are highly knowledgeable and skilled. At first, the new recruiter will shadow the mentor on recruitment visits to observe how to conduct an eligibility interview. The new recruiter should observe how the mentor makes the initial contact, explains the MEP, conducts an interview (paying particular attention to what questions are asked to determine whether the child is eligible for the MEP), and handles questions, problems, or concerns that arise. After each visit, the mentor and new recruiter should debrief and discuss the interview and eligibility determination. The new recruiter may find it helpful to shadow several mentor recruiters to observe the different strengths of each.

After watching several interviews, the new recruiter should begin to conduct a small part of the interview with the mentor's guidance. Each time the new recruiter conducts a part of an interview, the recruiter should talk with the mentor about how the interview went and ask the mentor for feedback or advice on how to improve for the next interview. This conversation should be away from the family or youth that was interviewed. As the new recruiter's interviewing skills improve, he or she can take over more of the interview process until comfortable conducting a full interview. By the end of the peer-mentoring portion of the training, the recruiter should be able to properly conduct an interview, determine child eligibility, complete a COE form, and perform other key duties.

Sometimes, especially in small states and very isolated areas, mentoring may not be practical. In this case, the recruiter should try to practice interviewing through a role-playing exercise during the classroom training, perhaps with another new recruiter. Practice is important as it makes the actual interview flow naturally and helps to ensure that the recruiter collects all of the required information to complete the COE and make the preliminary eligibility determination. In situations like this, the recruiter should discuss with their supervisor other ways to obtain adequate training and/or mentoring opportunities including contacting a nearby state able to send an experienced recruiter for a limited time (three to four days).

Some states require the recruiter to pass a certification exam or answer questions to demonstrate the recruiter's knowledge of child eligibility requirements. The purpose of these tests is to assess whether the new recruiter fully understands program eligibility requirements and can apply them to determine if a child is eligible for the MEP. If the recruiter's state does not have a certification exam or knowledge check, the recruiter should conduct a self-check to test how thoroughly he or she understands the MEP child eligibility requirements (see Appendix IX). If the recruiter does not pass

the certification exam or knowledge check, the recruiter should talk with an immediate supervisor to find out which topics to study and arrange for further training.

On-the-Job Training

Learning how to recruit properly is a process that does not end when the recruiter has finished the training activities. The recruiter will continue to learn as he or she identifies and recruits migrant children. It is important for the recruiter to ask questions about any eligibility situation that is unclear and to seek direction and guidance from supervisors and peers to become highly knowledgeable and skilled.

Regular Meetings with the Supervisor. The new recruiter should meet regularly with the immediate supervisor to discuss child eligibility questions and other concerns that arise. Ideally, a supervisor will provide regular feedback during the training process; however, it is equally important for the recruiter to ask for regular feedback on whether he or she is properly applying the child eligibility requirements. This is vital during the first few months on the job to prevent any misunderstandings from becoming ingrained.

Performance Assessments by Supervisors. As part of the system of state quality controls, SEAs or LOAs are required to complete an annual review and evaluation of ID&R practices of individual recruiters. See 34 C.F.R. § 20.89(d)(2). While supervisors may conduct a performance review with seasoned recruiters in an office setting, supervisors generally observe each new recruiter in the field. This allows a supervisor to provide comprehensive feedback on the recruiter's rapport building, interviewing, decision-making, and documenting skills. The purpose of this observation is for the supervisor to see how the new recruiter approaches interviewing migrant families and making and documenting preliminary eligibility determinations. It is imperative that supervisors schedule observations with new recruiters. The recruiter should also request feedback on completed COEs to make sure they are being done properly.

Regular meetings and performance assessments also present an opportunity for the new recruiter to suggest ways of improving local ID&R efforts and to identify any training and development activities that would increase productivity. Suggestions from a new recruiter can be particularly useful to the supervisor because a new recruiter will view the system with fresh eyes and may be able to identify productivity solutions that are invisible to those who are comfortable with the process.

Recruiter Support System. The new recruiter should develop a network of other recruiters locally, regionally, or even nationally with whom to share tips and discuss problems. Recruiting can be stressful work; it is important to create a safe learning environment in which the recruiter feels free to share experiences and to learn from successes and failures. The recruiter may find it useful to work with mentors, peers, and the recruitment network to develop an individual ID&R action plan or to adapt an existing plan (more information on ID&R plans is provided in Chapter 5). The recruiter is encouraged to try promising new ID&R strategies and to share the results (both good and bad) with peers.

The recruiter may find it helpful to go on recruitment visits with outreach workers from other programs or agencies. For example, a recruiter may wish to join outreach staff from the National Farmworker Jobs Program (NFJP), administered by the U.S. Department of Labor, to learn how they approach migrant families and to learn more about the services they provide (more information on other agencies and organizations that provide services to farmworkers and their families is found in Appendix II).

Advanced Training and Ongoing Professional Development

The law that authorizes the MEP is updated every six to eight years, and ED then generally develops updated MEP regulations and Guidance. Periodically, there are changes to other federal and state laws that affect migrant families as well, such as immigration or privacy laws. To properly identify and recruit migrant children the recruiter must keep up with changes in the law, regulations, and Guidance that affect the eligibility of migrant children (more information on other laws that may affect migrant families is found in Appendix I).

To stay current the recruiter should participate in advanced child eligibility training and ongoing professional development to continually update and improve needed knowledge and skills. The recruiter should make a point of attending local, regional, statewide, and national trainings when possible. Regardless of years of experience, recruiters and supervisors who do not participate in ongoing eligibility training are more likely to make mistakes when making child eligibility determinations than those who are trained regularly. In particular, experienced recruiters may be tempted to apply policies that were learned as new recruiters out of habit, even though those policies may be out-of-date. Timely training and regular meetings can help experienced recruiters overcome these old habits. Some questions a recruiter may want to answer after going through advanced eligibility training include:

- Have any changes been made to the child eligibility requirements for the MEP? If so, what are they?
- How do I determine child eligibility in difficult cases?
- How can I strengthen my recruitment network?
- How can I improve my interviewing skills?
- What common mistakes have recruiters made in determining child eligibility and/or filling out COEs and how can I avoid making those mistakes?
- What ethical dilemmas could I encounter and how do I handle them?
- How are these and other recent changes reflected in my district, region, or state?

The recruiter, with the supervisor's approval, may also want to explore professional development opportunities in other relevant areas, such as education reform, the language and culture of local migrant families, transient populations, negotiation skills, dealing with difficult people, public speaking, immigration issues, agricultural issues, time management, stress management, and safety and emergency training. The recruiter can check the listings at local universities, colleges, community centers, and other organizations for relevant course offerings and training.

In addition to training offered by the state, OME hosts an annual conference in which the latest information on MEP-specific issues, including eligibility and recruitment topics, are presented. It is important to note that not all states have the same policies and practices; therefore, it is crucial that conference participants check with their state or local administrators before implementing policies or practices presented at the OME Conference. Information on the conference can be obtained from the RESULTS website at <http://RESULTS.ed.gov>. In addition, there are regional, state, and national conferences, trainings, workshops, and meetings that include sessions and information on ID&R.

Conclusion

There are a number of ways in which the recruiter can learn the job of ID&R: participating in a new recruiter training program, studying the Guidance and other key resources, working with a mentor, meeting regularly with a supervisor, and developing a support system. Having knowledgeable and well-trained recruiters is an ongoing responsibility of both the individual recruiter and the MEP administrator. Regardless of what training opportunities are available, it is the recruiter's job to work with the supervisor to learn the MEP child eligibility requirements and to ask the supervisor for help when questions arise on whether a child qualifies for the MEP. Remember, regardless of the size of the migrant student population, and whether the recruiter's position is full-time or part-time, all states hold recruiters to the same standard: to conduct timely and proper identification and recruitment of eligible migrant children.

The first step in the process of determining if children are eligible for the MEP, however, is to locate them. Chapter 4 provides specific information on how to find migrant children.

Recruiter Checklist

Chapter 3: Learning to Recruit

Did you?

- Complete your state's requirements for basic training?
- Read and study the Guidance?
- Review the knowledge and skills needed to identify and recruit migrant children?
- Meet with your supervisor to ask questions, particularly on child eligibility?
- Conduct a "self-check" of whether you understand MEP child eligibility or pass a state certification exam or knowledge check where required? See Appendix IX.
- Find a knowledgeable mentor?
- Observe one or more experienced recruiter(s) interview a migrant parent or youth?
- Determine where you need more training and request it?
- Identify other recruiters with whom you can share ideas?
- Arrange to be observed by your supervisor?
- Find out where to go to ask questions?
- Provide feedback on ways the training can be improved?

Chapter 4. Building a Recruitment Network

*Networking is a supportive system of sharing information and services among individuals and groups having a common interest.*¹

Finding Migrant Children

The recruiter often finds locating migrant children to be the most time consuming and labor intensive ID&R responsibility, particularly since the children who have the greatest needs are often the most difficult to find. While recruitment consists primarily of finding and interviewing families, it is by no means a simple task. The process is strenuous and requires many skills including communication and building effective relationships with migrant families and youth, the agricultural community, and service providers who work with migrant families. The recruiter should also learn how to approach key community leaders to make them aware of the MEP and to gain their respect. Over time, experienced recruiters recognize that migrant families, agricultural employers, and service providers who work with migrant families are helpful to the recruiter in locating other migrant families, children, and OSY. Building this level of personal trust and an awareness of the benefits of participating in the MEP should be every recruiter's goal.

This chapter addresses the type of research the recruiter and other MEP staff should conduct to learn about local agricultural activities, farmworker labor, and organizations that serve the local migrant community. This information will help the recruiter and supervisor determine the best way to identify and recruit eligible migrant children.

Conducting Research

The value of developing key contacts within the migrant community cannot be overstated. As a starting point, the recruiter should learn as much as possible about his or her recruitment area. In particular, the recruiter should find out what is known about the local migrant community and which local people and organizations are trusted within that community. Local people and organizations are the recruiter's best sources of current and accurate information and referrals. Once the recruiter has identified these important contacts, the recruiter should determine how best to build strong working relationships, to exchange information on an ongoing basis, and to promote the MEP.

The recruiter may be instructed by their supervisor to "talk with farmers" or "go to the schools." But a new recruiter, or even a seasoned recruiter taking on a new territory, needs to know *which* farms and schools are the most likely to have migrant children in order to be productive. Conducting basic research will help the recruiter find migrant children more quickly and efficiently. This is particularly true for those children who are not in school and are more difficult to identify, such as preschool children and OSY.

¹National ID&R Curriculum, Funded by U.S. Department of Education, V2.0, Source: dictionary.com retrieved on -line 02/03/12.

Some key questions the recruiter should try to answer through this research include:

- What is already known about migrant workers in my local area?
- Who are the local agricultural and fishing employers?
- What are the employers' work activities (e.g., packing freshly picked apples)? Which of their jobs are temporary or seasonal?
- Which employers hire migrant workers (i.e., workers who have moved to this community to do this type of work)?
- Where are the employers located?
- Where do the migrant families who work for these employers reside in the local area (e.g., migrant labor camps, inexpensive apartments, trailer parks)?
- Where do the migrant workers in the area come from (i.e., where do they consider their home base to be)?
- When do migrant workers leave the area (i.e., what time of year)? Do they look for temporary or seasonal employment in agriculture and fishing in other places? When do they return?
- Where do migrant workers go to seek employment?
- What type of seasonal or temporary employment do they seek?

This type of information can be found through a number of sources including web sites and the field offices of federal, state, and local agencies that focus on agriculture, fishing, labor, and housing issues. Local educational agencies (LEAs) and community organizations that work with migrant families are also good information sources.

Some general Internet sites can be helpful resources for a recruiter. For example, a recruiter can go to an Internet mapping service (e.g., <https://maps.google.com>, <http://www.mapquest.com>) and enter the name of a local town and state and a search word (e.g., migrant, orchard, farm, nursery, name of a specific crop, laundromat). The mapping service will provide names and addresses of businesses or organizations related to the search word along with a map that indicates where each is located. More information on using electronic tools to recruit is discussed later in this chapter and a list of resources that the recruiter can use is found in Appendix II of this manual.

In some communities migration patterns are so well established that the local MEP staff know in which residences migrant families and youth live and which employers hire them. In these areas, the MEP staff can often share successful, time-tested methods for finding and enrolling migrant children. Also, many MEPs have recruitment databases that contain helpful information including a list of employers in the area who hire temporary and seasonal migrant workers, approximate dates of workers' arrivals, the jobs conducted by workers, and their housing unit locations. While recruiters in areas that receive migrant workers may first go to the local migrant labor camps to interview families, the recruiter should also look outside of traditional locales because migration, employment, and housing patterns may change over time. Although a specific approach and strategy may have

been successful in the past, this does not mean it will always be successful. It is important for the recruiter to continually conduct new research to find all eligible migrant children in the recruitment area.

Terminology Used to Describe Migrant Farmworkers

Over time, recruiters have developed a shared vocabulary of terms related to ID&R. Knowing these terms makes it easier for the recruiter to conduct research to effectively locate local migrant workers and their families. While states and local project sites often develop their own terms, the following are terms that are commonly used in many states that recruiters may benefit from knowing.

Home Base. Many migrant families have a home base, or hometown, where they live for much of the year. They travel or migrate from this home base to other places to work for temporary or seasonal work out of economic necessity. For example, a migrant family might consider Florida to be their home base; they live in Florida all winter and work through the citrus harvest in the spring, but then they move to South Carolina to work during the peach harvest. They might also travel to other states or locations and then return to their home base in Florida in the fall.

Send and Receive. A location may either send migrant workers (i.e., workers live in a particular place for most of the year but move to other places to work) or receive migrant workers (i.e., workers come from other places to this place to work). In the example given above, Florida is the family's home base, so Florida is the sending state. When the family moves to South Carolina to work, South Carolina becomes the family's receiving state. Some areas send *and* receive migrant families. A county may receive migrants who move from state to state (interstate) as well as migrants who simply move from place to place within a state (intrastate).

Migrant Streams. Historically, the majority of migrant workers were believed to follow one of three distinct patterns of migration: (1) the Eastern stream, (2) the Mid-continent stream, and (3) the West Coast stream. The Eastern stream flowed east of the Appalachian Mountains, the Mid-continent stream flowed to and from Texas in all directions, and the West Coast stream flowed between Arizona, California, Oregon, and Washington.

Follow-the-Crop Migrants. The term "follow-the-crop migrants" comes from the U.S. Department of Labor's National Agricultural Workers Survey (NAWS). The term refers to workers who travel at least 75 miles to "multiple U.S. farm locations" over a 12-month period in order to work. This term is now a relative rarity. These workers make up just 5 percent of those surveyed by the NAWS in 2007-09, down from a high of 14 percent in 1992-94.¹

Shuttle Migrants. The term "shuttle migrants" also comes from the NAWS. The term refers to migrant farmworkers who move more than 75 miles between a home base in the off-season and one or more farm job(s) located in the U.S. during the harvest season. For example, a migrant farmworker who lives in Mexico, travels to the U.S. to obtain a seasonal farm job in agriculture, and then returns

¹ United States Department of Agriculture, Economic Research Service. Retrieved from <http://www.ers.usda.gov/topics/farm-economy/farm-labor/background.aspx>. (July, 2012)

home to Mexico to live inexpensively or to supplement his or her farm earnings with nonagricultural work during the off season is considered a shuttle migrant. Shuttle migrants can travel both domestically (i.e., within the U.S.) and internationally. The term is not defined for purposes of establishing eligibility for the MEP.

Bi-national shuttle migrants (usually between Mexico and the U.S.) are often sensitive to changes in economic conditions, employment opportunities, and immigration policies. As these conditions change, so do the migration patterns of workers (e.g., when migrant workers move, where they move from and to, how many move, what type of employment they seek, etc.). The recruiter needs to be aware of any changes in migration patterns.

Settled Out. This term means that the migrant child or family has become permanently established in an area and has stopped migrating for seasonal or temporary farm work.

Identifying Important Information Sources

When I started recruiting, I talked to the recruiters who found the most migrant children. I asked if they would introduce me to the people who were the most respected by migrant families. Over time I've developed many good friends, and they help me do a better job of finding migrant children.

As the recruiter begins researching the local migrant community, the recruiter should become familiar with the information sources that are essential to building an effective recruitment network. As explained in this chapter, a recruitment network is a system of contacts, including individuals, agencies, and other institutions, that provides information on identifying and locating potentially eligible children. Establishing a recruiting network and developing a strong working relationship with each member of that network is an important way of finding migrant children who could be eligible for MEP services. When done properly a recruitment network can serve as the eyes and ears of the recruiter.

The five most common information sources when building a recruitment network are:

1. Employers;
2. Local school staff;
3. Community contacts, organizations, and commercial establishments;
4. Other government agencies; and
5. Migrant families and youth.

The recruiter should encourage members of the recruitment network to refer potentially eligible children to the MEP. At the same time, the recruiter should let network members know that only MEP staff can determine whether a child is eligible to receive MEP services. As a result, network members should be careful not to promise families that their children will receive services. The key sources of information to consider in establishing a recruitment network are discussed below.

In my state, our relationship with local growers is so good that they give us a carbon copy of the pre-employment forms that job candidates fill out when they apply for work. They avoid privacy concerns by having the applicant sign an agreement that the information can be shared. The pre-employment forms help us recruit more efficiently and we also staple it to the hard copy of the COE to corroborate the worker's employment.

Employers. The recruiter should identify the local employers that are the most likely to hire migrant agricultural or fishing workers. Once identified, it is important to establish good working relationships with them and to explain the value of the MEP, since employers can serve as the greatest allies in the recruiter's ID&R efforts. Making a good first impression with agricultural employers is key; their cooperation is necessary for the recruiter to gain entry to places where migrant families and youth work and to obtain permission to interview migrant workers during work breaks or after hours.

To break the ice with a new employer it is often beneficial for an administrator to pave the way for the recruiter by sending a letter to the employer that explains the MEP and asks for the employer's help in identifying potentially eligible children. The administrator may also wish to follow up with a telephone call (see Appendix V). Once the administrator has made this initial contact, the recruiter can contact the employer directly, using the letter as a conversation opener. It is important for the recruiter to gain the trust of the employer, which can be done by demonstrating honesty, responsibility, confidentiality, and consideration to the employer. The recruiter should maintain regular communication with the employer while being mindful that farmers are busy people. The recruiter should make sure not to overburden the employer with constant inquiries as this is sure to diminish their working relationship. The recruiter should do their best to make conversation direct and to the point. Additionally, the recruiter should take notice of times when the employer seems less busy, as these times provide quality opportunities to build relationships. When an employer is dealing with a crisis on the farm the recruiter should turn around and come back another time; this is not the time to promote the MEP. The recruiter should wait for a time that is convenient to the employer to explain the purpose of the program and how the employer might benefit from participating in the recruitment network. The best chance for a successful working relationship with agricultural employers is to create a win/win situation. For example:

- Many workers have children and will seek employment in areas that can provide extra services for their children.
- Workers whose children are engaged in school are less likely to leave their jobs, which reduces costs associated with employee turnover.

- Workers whose children are engaged in school are often more productive since they are less concerned about their children and, therefore, better able to concentrate on their jobs. Their children are less likely to be brought to the workplace (creating a liability problem for the employer), to miss school in order to care for a younger sibling, or to be left in an unsupervised home.
- A small investment of time on the part of the employer can result in a happier workforce and better relationship with the larger community.

Because of these benefits, employers are generally supportive of having employees and their families participate in the MEP. In addition, the recruiter can provide other valuable resources to an employer, such as referring migrant families to other useful services including a local migrant health clinic. The recruiter should also build relationships with migrant labor contractors or crew chiefs who can alert the recruiter when new workers who have children are hired.

The recruiter should develop and maintain profiles of the major employers that hire temporary or seasonal agricultural or fishing workers in the local recruiting area. When consolidated, these individual profiles will create an informational directory that the recruiter can expand over time, ultimately serving as the primary agricultural recruitment tool. This resource is not only beneficial to the current recruiter, but it also builds a historical record for future recruiters who may one day take over the region. A profile survey form could include:

- General information regarding the workplace (e.g., name, owner, foreman, etc.)
- Directions to the work site
- Crops or products, hiring practices (i.e., peak hiring dates)
- Housing offered
- Other facts pertinent to the specific geographic MEP area or work conditions

The profile form could also include personal notes that are helpful for the recruiter's future reference, such as where the employer prefers the recruiter to park or the best times of day to visit. Additionally, profiles can reference safety concerns or anecdotes summarizing positive and negative experiences at the work site. A sample workplace survey form that can be used to gather profile data is included in Appendix III. Other sample survey forms are also provided.

Schools. The local schools are another important source of information for the recruiter since schools collect information on every child who enrolls and withdraws. Developing school-based information sources requires the recruiter to think about with whom migrant families are likely to interact within the school (e.g., school secretaries, registrars, attendance clerks, school nurses, guidance counselors, teachers, superintendents, principals, bus drivers, cafeteria workers, Title I, Part A, and Title III staff). For example, the family will go to the main office to register, see the nurse to have immunization or health records checked, and in the case of secondary students, visit a guidance counselor to develop the student's class schedule and check transcripts. A knowledgeable and cooperative secretary can be helpful to the recruiter by referring potentially eligible students and their families to the MEP. In many cases, migrant children ride school buses that transport them to

and from school. When bus drivers are educated about basic eligibility requirements, they can inform the recruiter when new children board the school bus at places where farmworkers often live. It is important to ensure that these valuable contacts are aware of the MEP and know how to contact the recruiter with leads.

It is also important to carefully establish and nurture a relationship with district and/or school administrators. Administrators can support the recruiter's efforts by providing access to key district or school staff, providing information on newly arrived children, and communicating throughout the system that the recruiter's work is important to the district, schools, and families.

Community-based Organizations and Commercial Establishments

We get permission from the local grocery stores that migrant workers shop at the most often to put flyers about the Migrant Education Program in grocery bags.

Many local community organizations are funded to provide outreach, social, health, or legal services to migrant and seasonal farmworkers. The recruiter should think about which organizations and services migrant families and OSY are most likely to use in the local community. For example, migrant families may attend local churches, wash their clothes at the local laundromat, shop at local ethnic food markets and flea markets, enroll in ESL classes, enroll their children in Head Start, visit community health centers, and use local cultural centers. They may also receive benefits from local service agencies or farmworker organizations. The recruiter should also think about which agencies and organizations collect data on migrant workers or communicate with farmers in the area (e.g., farm bureaus, growers' associations).

As with the employers, the recruiter should develop a listing or profile of the businesses or organizations that are the best sources for locating migrant families and OSY. Some communities have interagency committees that work together to coordinate the services that they provide to migrant families and OSY, and may even have community service fairs for migrant workers during peak hiring periods. At service fairs, local service providers typically set up temporary intake offices in a single location to allow migrant families to sign up for a number of benefits and services at one time. This provides a great opportunity for recruiters to enroll migrant children in the MEP and to share important information.

Temporary agencies are another good source for finding leads on seasonal and temporary farmworkers. Many temp agencies provide workers for farms and processing plants on a regular basis. Working with these agencies may open another door to potentially eligible migrant families.

It is also important for the recruiter to think about where migrant families are likely to live, such as migrant labor camps, local apartment complexes that offer month-to-month leases, or shared houses or trailers (sometimes located on the farm itself). The recruiter should cultivate relationships with the owners or managers of these housing units because they can become vital members of the recruitment network. For example, they can alert the recruiter when migrants begin moving into the community. The recruiter should visit migrant housing regularly since housing complexes that have previously housed migrant families and/or OSY may have changed policies for accepting new

tenants. In this case, the recruiter will need to determine where these workers now reside and start building a relationship with the owners or managers of those units.

Some organizations may not be able to share their contact lists, but may be willing to include information about the MEP in mailings that they send out to local farmers.

Other Government Agencies. The MEP is not the only government program that serves the migrant community. For example, the U.S. Department of Health and Human Services' Health Resources and Services Administration (HRSA) provides grants to public and nonprofit health centers that support the development and operation of migrant clinic sites throughout the United States and Puerto Rico (<http://bphc.hrsa.gov/about/specialpopulations/index.html>). The Migrant and Seasonal Head Start Program provides grants to local public and private non-profit and for-profit agencies to provide comprehensive child development services to preschool children of migrant and seasonal farmworkers and their families, with a special focus on helping preschoolers develop the early reading and math skills they need to be successful in school. Other programs that serve the migrant community may include the Women, Infants, and Children (WIC) Program, the Housing Assistance Council, the Migrant Clinicians Network, Rural Opportunities, Inc., and Head Start Centers. The recruiter should keep in mind that not all organizations have the same definition of "migrant" as the MEP, and should check with each organization before referring clients. The recruiter should also realize that not everyone who is served by these programs is eligible for MEP services.

Each state has a land grant college or university that addresses agricultural issues and supports a statewide system of Cooperative Extension offices. Extension agents and outreach professionals for each Cooperative Extension office often have in-depth knowledge of local farms and crops and have many contacts in the farming community. Cooperative Extension offices may also offer annual statewide activities, such as farm shows or agricultural days that are good places to meet employers. In addition to local Cooperative Extension offices, recruiters may find the national online extension site (<http://www.extension.org>) a valuable resource. eXtension is an interactive learning environment delivering researched information from land grant university minds across America. The recruiter can enhance their knowledge of agricultural crops and industries to better understand and communicate with the farm community in their recruitment regions. Furthermore, the recruiter can find useful research and articles specifically on migrant farmworkers by typing "migrant" into the search engine.

In addition to Cooperative Extension offices, state Departments of Agriculture are another diverse source of information for the recruiter. Most state Departments of Agriculture have marketing boards for the different commodities, such as meat, dairy, fruits and vegetables, etc. These boards are composed of employers and can provide the MEP with access to other employers. Additional sources of information might include state agencies that license or inspect migrant labor camps, National Farmworker Jobs Training Grantees¹, and One-Stop Career Centers².

¹ A web-based directory can be found at <http://www.doleta.gov/MSFW/html/docs/ServiceContacts.cfm>.

² Many One-Stop Career Centers have outreach workers that visit migrant workers regularly. To identify whether a One-Stop Career Center has an outreach worker, you may contact the center directly or contact the State Monitor Advocate. The location of the One-Stop Career Center can be found at <http://www.servicelocator.org/>. Contact information for the State Monitor Advocate can be found at <http://www.doleta.gov/programs/MSFW.cfm>.

Some government agencies maintain electronic tools that may be of assistance to the recruiter. For example, the National Agricultural Statistics Service (NASS) operates a comprehensive on-line database on agricultural production. NASS conducts hundreds of surveys every year and prepares reports covering virtually every aspect of U.S. agricultural production including numbers of hired farm labor and contract farm labor. Data are available at the state and county level; some data are available by zip code. There is also an Interactive Statistical Map (see Figure 2, below).

Figure 2. The National Agricultural Statistics Service Website

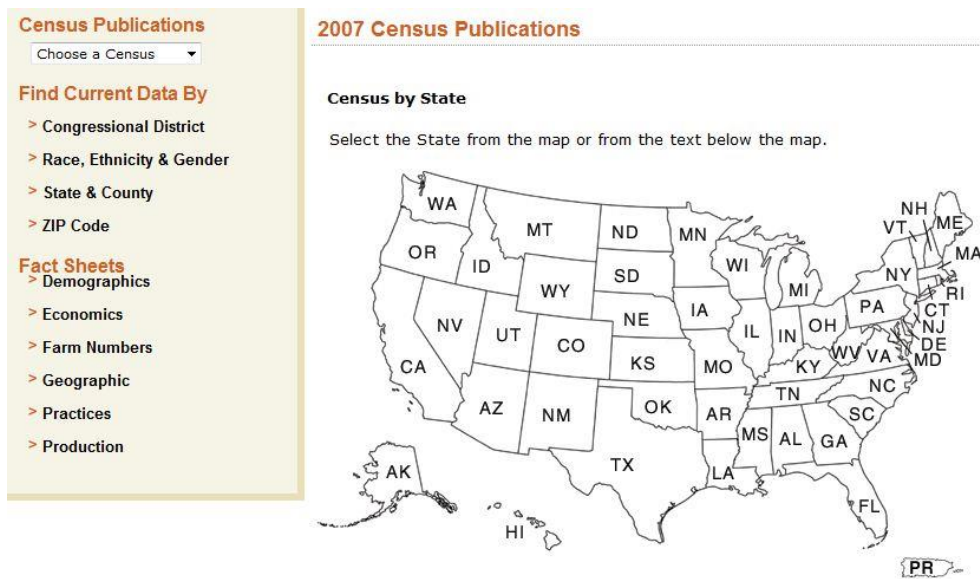

The web address to conduct a county level search is

http://www.agcensus.usda.gov/Publications/2007/Full_Report/Census_by_State/.

While the data obtained can be valuable in finding out total production data, information about individual farms is not available to the recruiter on the NASS site.³

Another diverse resource is the Department of Labor. This is the government agency that manages the NAWS. This survey is the most comprehensive employment-based, random survey of the demographic, employment, and health characteristics of the U.S. crop labor force (<http://www.doleta.gov/agworker/naws.cfm>). The Department of Labor also maintains the iCERT Visa Portal site (<http://icert.doleta.gov/index.cfm>). This site provides current and past job order postings for H2A workers made by agricultural employers. The H2A temporary labor certification program allows farms to contract temporary workers when local labor force is not available. While not all H2A workers are eligible due to MEP age requirements, the recruiter may find this site useful for identifying agricultural employers who contract H2A workers. The site is user friendly.

³ National Agricultural Statistics Service (NASS), *NASS Census of Agriculture*, [online database], available at <http://www.nass.usda.gov/> (July, 2012)

Migrant Families. It is important for the recruiter to develop strong relationships with migrant families. Migrant parents can inform the recruiter about the kinds of community activities they participate in and the services they use, which is useful information as the recruiter develops a recruitment network. Additionally, migrant parents whose children are currently in the MEP can often provide information regarding other migrant parents who live in their neighborhood, go to their church, or work at a neighboring farm. Finally, migrant families who have had good experiences with the MEP are more likely to seek out the MEP when they move to a new town.

Migrant Out-of-School Youth (OSY). OSY have unique needs resulting from their migrant lifestyle. Some recruiters state it is even more difficult to locate and recruit the OSY population than it is to locate and recruit migrant families. Fortunately, providing services to OSY can be very rewarding. OSY need advocates: people who can both motivate them and help them access needed services. Young people not in school have little or no access to federal or state resources.

Building Relationships and Gathering Data

Recruiting students by waiting in the school for migrants to come through the door is like lying under a cherry tree with your mouth open. Sooner or later, a cherry will fall in your mouth, but look at all of those you lost out on.

The primary benefit of a recruitment network is to get referrals of potentially eligible migrant children and youth. For example, a community healthcare worker in an agricultural region may notify the MEP if a large number of new families have their children immunized at the local clinic at spring planting time. Each time the recruiter interviews a migrant family the recruiter should ask if the family knows of other migrant families or OSY in the area that the recruiter should visit. Furthermore, the recruiter should actively seek out new organizations to add to the recruitment network. It takes time and effort to build and sustain a recruitment network since the recruiter must continually make fresh contacts, as well as nurture long-standing contacts. However, the benefits outweigh the time commitment required. Here are some strategies for building and maintaining networks.

Personal Relationships Build Professional Relationships. Migrant families often use personal relationships to share information about jobs, housing, schools, and services (including MEP services). Information shared within these informal networks often moves faster than more formal communications (e.g., learning about job openings by word-of-mouth versus in a newspaper). The recruiter can learn valuable lessons from migrant families about how to develop and maintain a network. Over time, the recruiter will develop his or her own networking and communication strategies to develop a strong professional recruitment network.

First Impressions. Making a good first impression can be critical when a recruiter meets a potential member of the recruitment network. The recruiter should be friendly, but should also be sensitive to the responsibilities and workload of the contact. The recruiter who is met with resistance may find it helpful to locate someone who already has a good relationship with the contact and who can allay any concerns the contact might have about the MEP (e.g., a peer, a respected school or community leader, another local agricultural employer who has given permission to do so, or a migrant family who is familiar with the MEP).

Importance of Trust. It is important for the recruiter to earn the trust of migrant families and agricultural employers, as well as the trust of professional organizations that serve the migrant community. Migrant families often have good reasons for being careful about whom they trust. They are vulnerable because they may not have legal standing in the U.S. or financial security. In addition, the word migrant may have a negative connotation attached to it for some families, so the recruiter may need to be careful about terminology. In other languages, the word migrant may imply or be confused with immigration status. Organizations that work with migrant families recognize the importance of maintaining the trust of their clients and therefore are careful about the information they share and with whom they share it.

The recruiter who is trusted by migrant families and youth reaps many benefits including having migrant families seek him or her out to enroll their children in the MEP and refer other migrant families to the program. Families are also more likely to share the personal employment and family information that is needed to document their children's eligibility for the MEP (including qualifying employment that may have been performed without a legal work permit or for cash). The recruiter who is trusted by those who work with migrant families can gather important information on where migrant families gather, live, and work.

Trust is built slowly and is based on the experiences migrant families and organizations have with the individual recruiter and with the MEP. Some steps the recruiter can take to build trust include the following:

- Provide clear information on why the recruiter is interested in finding migrant families.
- Describe what migrant families can expect from the MEP.
- Keep promises to migrant families and organizations; be careful not to make promises that cannot be kept.
- Protect the family's privacy and confidentiality by not discussing other migrant parents and children except in the most positive and professional manner. Always ask permission before sharing information with other professionals or organizations (in writing, if needed).

Develop a Personal Relationship. As with everything else, personal relationships are key to achieving success and to feeling fulfilled. This is true for *both recruiters and members* of the recruiter's network. Learning specific information about key contacts can help the recruiter develop an effective professional relationship with members of the recruitment network. For example:

- What is the crew chief's name?
- When is the school secretary's birthday?
- Has a local farmer fully recovered from a recent illness?
- When is the best time of day to catch Jaime, an OSY?
- Where do local migrant workers congregate on a Saturday night?

Many successful recruiters make an effort to learn these types of details, include them in their contact sheets, and act on them. For example, the successful recruiter asks about the secretary's children each time they meet, wishes people a happy birthday, asks for the crew chief by name, visits Jaime at 7:00 p.m. after he gets off work, and participates in the social life of the migrant community.

Communicate Regularly. The recruiter should maintain ongoing contact with the members of the recruitment network by attending key meetings and events. Schools, employers, and community service providers may have their own meetings, or may have collaborative groups that meet for everyone's benefit. In addition to maintaining professional contacts, this is an opportunity for the recruiter to educate the recruitment network on the MEP. If it is not possible to have ongoing one-on-one contact, there are other ways the recruiter can develop and maintain professional relationships. For example, occasional telephone calls can be an effective way of reminding contacts about the services and successes of the MEP. It is important that the recruiter follow up with contacts regularly to get new information and to let the contact know the relationship is valued.

Follow Up Quickly on Referrals. Each time the recruiter receives a referral it is important to call or visit the contact to acknowledge the referral and to share the results, particularly if it resulted in a child's enrollment in the MEP. Many programs send cards or official letters from the MEP offering thanks. Taking the time to follow up with contacts validates their effort and good will and can motivate them to provide future leads.

If the recruiter does not follow up on leads quickly, migrant children may not receive extra support and educational services they urgently need. Furthermore, contacts may stop providing leads if the recruiter does not visit the family or youth in a timely manner.

Getting information through personal contacts is one of the most valuable strategies the recruiter can employ. The recruiter should think carefully about how to establish good relationships with key members of the recruitment network, and how to increase their awareness and understanding of the MEP. For network contacts to understand the benefit of sharing information, the recruiter and the MEP must be perceived as credible and as delivering a quality service.

Surveys/Questionnaires. Surveys are another effective way of gathering information from the recruitment network. Survey forms often vary depending on where and how they are administered. However, common survey questions often include:

- Have you or your family moved within the past three years?
- Have you looked for work in agriculture or fishing?

Some programs try to ask questions in more than one way on a survey form in case the reader does not fully understand the question the first time. The following are common types of surveys:

- **Employer/workplace surveys.** The recruiter should survey local employers to determine which ones are the most likely to hire migrant workers (see the sample Migrant Education Workplace Survey form in Appendix III). Once the recruiter has identified these employers, the recruiter should encourage them to have new employees complete a MEP survey as part of the hiring process. Other programs have found success by having MEP surveys and recruiter contact information inserted in with workers' paychecks. The purpose of the MEP survey is to identify those workers who are the most likely to have children who qualify for the MEP (See the sample Migrant Education Employee Survey form in Appendix III.)
- **School surveys.** The recruiter should determine the schools that are the most likely to enroll migrant students based on the presence of a local agricultural community and industry and ask them to distribute migrant surveys to every family during the annual registration process. These schools should also be encouraged to distribute surveys to families who enroll their children after the school year begins (See the sample Migrant Education School Survey form in Appendix III.)
- **Community agency surveys.** The recruiter should encourage community agencies to include screening questions as a part of their intake process to help the MEP identify migrant families. At the same time, the recruiter may refer families to these agencies, where appropriate. This two-way cooperation benefits all involved. Sometimes agencies will want the recruiter to refer clients to them but will not reciprocate. If this is the case, the recruiter should advise his or her direct supervisor. A meeting on the supervisory level between the agency and the MEP may resolve the problem.

The recruiter should ask if the state or local project has conducted any surveys. If so, the recruiter should find out what forms were used and when the surveys were last updated. If the state has not been conducting surveys, the recruiter should initiate the process. As mentioned previously, over time, the collection of surveys will serve as a detailed directory for the recruiters key recruitment networks, samples of surveys are provided in Appendix III.

The recruiter should be aware that survey forms alone are not sufficient to record or document a child or youth's eligibility for the MEP. However, information obtained through surveys provides a good starting point for recruitment efforts by identifying those families who are the most likely to have children who qualify for the MEP, the employers who are the most likely to hire migrant laborers, etc. All states are required to use a COE form to document a child's eligibility for the MEP (see Chapter 8 for detailed information on completing the COE).

I work closely with the Chamber of Commerce and give out materials from the local town such as lists of business and community resources, maps, and emergency contact phone numbers.

Promotion. In addition to using the recruitment network for referrals or surveys, the recruiter can also use the network to promote the MEP. To use this strategy, the recruiter provides promotional materials to employers, schools, community organizations, and previously recruited migrant families to share with other families that might be eligible for the MEP. In this way, migrant families learn about the MEP and can contact a recruiter to see if they are eligible for services.

Promotion through a network can happen in a variety of ways. The National Institute of Cancer's *Pink Book* identifies several ways to promote a program, including interpersonal, organizational, or mass media promotions, as described below:¹

Interpersonal Promotion. Every time a contact in the recruitment network meets with a family, interviews a family, or makes a home visit, there is an opportunity for that contact to share information about MEP services and to disseminate information about the MEP. Other examples of interpersonal promotion include using a hotline that migrant families can call when looking for MEP services, or having informal discussions about the MEP at migrant "hotspots." Materials and equipment that can support interpersonal promotion include business cards and toll-free numbers. Even providing a small informational item like a school calendar may remind the migrant family that the recruiter and the MEP are available to help the child participate effectively in school.

Organizational Promotion. A common organizational promotion is to present at a community agency meeting or workplace to educate potential members of the recruitment network about the MEP. This could occur during a regularly scheduled meeting or at a special community fair. A particularly effective form of organizational promotion is providing awareness training about the MEP for key contacts (e.g., bus drivers, registrars, attendance clerks, school nurses, counselors, and teachers). Other common organizational promotions are MEP newsletters, articles in newsletters of other organizations that serve migrant families, posters, brochures, and display tables.

Mass Media Promotion. Mass media offers one of the best means of promoting the MEP to a broad group of people. Radio, television, and newspapers may reach remote areas that the recruiter cannot easily or efficiently explore. Local radio stations and newspapers may be willing to broadcast community service announcements that welcome migrant families to the area. These announcements should reflect the language and culture of the local migrant population (e.g., Spanish-language radio stations in areas where migrant families are predominantly Latino). Newspaper stories, letters to the editor, and visits from local politicians are all ways to maintain community awareness of the MEP and are examples of strategies that help the recruiter "get the word out." Posters left in strategic places such as churches, supermarkets, laundromats, convenience stores, auto repair shops, health clinics, and other locations that migrant families frequent can educate possible migrant families about MEP services.

The recruiter should be aware of community sentiment regarding migrant and farmworker issues; some communities may react to MEP mass media promotions in a negative way. If the recruiter is

¹ National Cancer Institute, *Pink Book—Making Health Communication Programs Work* [book on-line] (Washington D.C.: National Cancer Institute, n.d., accessed March 30, 2012); available at <http://www.cancer.gov/cancertopics/cancerlibrary/pinkbook>.

unsure how the local community will accept mass media promotions, he or she should talk with fellow recruiters and/or the state ID&R coordinator before including it in the ID&R action plan. Furthermore, the recruiter should follow state and local policies on media review, releases, and approvals. In any mass promotion, the recruiter should provide clear information on the basic eligibility requirements so as not to be flooded with families who need help but are not remotely eligible for program services. However, recruiters should avoid providing too much specific information on eligibility requirements so families do not *learn* the eligibility requirements and provide the information they believe the recruiter wants. In response to specific questions about eligibility criteria, it is best to say, “There are general eligibility requirements and guidelines, but program eligibility is determined on a case-by-case basis.”

Promotions may be particularly effective at reaching the migrant community in both densely and sparsely populated areas. It may be too difficult or expensive to recruit in these areas, so promotions can be used to encourage migrant families to find the MEP, rather than the reverse. Promotions can also be done through cultural or social clubs that may attract migrant farmworkers.

In any promotion of the MEP, it is important to present a consistent message. In particular, everyone who comes into contact with the MEP should have the same understanding of its mission. Promotions should also use uniform symbols or images. One of the greatest tools the recruiter can use is the national MEP logo (shown in Figure 3). Families who are familiar with the MEP may recognize the logo when they arrive in new areas. This familiarity can make the recruiter’s job easier.

Figure 3. The Migrant Education Program Logo.



Conclusion

In order to effectively conduct ID&R activities the recruiter needs to research the local migrant community, develop relationships with key contacts, build and use the recruitment network, and find migrant children. Gathering information on the migrant community before beginning recruitment activities can save both time and effort. Furthermore, it helps the recruiter prioritize key activities and manage time efficiently. Once the recruiter has identified areas that are likely to have migrant families and youth, the next step is to develop an individual action plan. Chapter 5 will discuss developing action plans, contacting migrant families, and safety while recruiting.

Recruiter Checklist

Chapter 4: Conducting Research to Building a Recruitment Network

Did you?

- Identify the local organizations and individuals who work most closely with the migrant community?
- Develop profiles of key local employers, school staff, community organizations, and the migrant community?
- Determine the best way to build relationships with each of these key contacts (e.g., find out how they can be assisted; provide awareness training on the MEP)?
- Follow up regularly with key contacts, particularly when they provide leads on local migrant families (e.g., call or visit them, attend important meetings, send thank you notes)?
- Work with schools, community organizations, etc., to see if they will include pre-screening questions for the MEP as part of their enrollment or intake process?
- Create a recruitment map that shows areas where migrant families are likely to live and work, services they use, and where their children go to school?

Chapter 5. Developing Action Plans and Contacting Families

Developing State, Local, and Individual ID&R Action Plans

Every year I work with the recruiters in my region to develop a recruitment calendar. The calendar lists the best times to recruit based on crop cycles, dates of important school events like school enrollment and kindergarten orientation, and when employers do most of their hiring. Each quarter, we compare what the recruiters planned to do with what they actually did and decide how we want to change the recruitment calendar for the next year. We've learned how to use our time more efficiently.

Now that the recruiter has determined where migrant families are the most likely to live and work, the recruiter needs to use that information to develop a personal recruitment action plan. Action plans come in many different forms and have different names (e.g., recruitment calendar, “to do” list, time management plan). The goal of an ID&R action plan is to become more efficient at finding all *eligible* migrant children.

Reasons for Developing an Action Plan. An action plan helps the recruiter, the supervisor, and other recruitment staff, organize and prioritize recruitment activities and establish timelines for their completion. The recruiter who has clear objectives and a plan for reaching them is more likely to be successful than a recruiter who leaves things to chance. The primary reasons for developing an action plan include:

- The process of creating an ID&R action plan forces the recruiter to think about what should be accomplished, to establish recruitment objectives, to decide the best way to attain these objectives, and to develop specific action steps and timelines for their completion.
- An ID&R action plan encourages the recruiter to be efficient and to use time wisely.
- ID&R action plans keep the recruiter focused and on task. Recruiters will face many different situations in the field and on the job; an action plan focuses the recruiter to a specific set of tasks.
- The completed ID&R action plan can serve as the basis for evaluating the recruiter's efforts and for continually adjusting and improving the recruiter's strategies for finding migrant children.
- If the recruiter leaves the job (e.g., retires, moves), the new recruiter has a clear blueprint of how to recruit in the local area.

Contents of an Action Plan. Action plans are developed at the state, local, and individual level. Here are some examples of what a plan at each of these levels could include:

1. *State.* The state action plan provides overall direction for recruiters from across the state. It includes the state's ID&R objectives, as well as strategies, staff assignments, and timelines to meet those objectives. The state action plan, which may be part of the comprehensive state plan for service delivery or the state's ID&R manual, could also include useful resources like:
 - A statewide map of where migrant families live and work
 - A calendar with seasonal crop activities
 - Profiles of major crops and employers
 - Recruiter resources (e.g., technical assistance provided by the state, toll-free numbers for recruitment questions, agencies that serve migrants, related web sites)
 - State laws and state and local recruitment policies (e.g., child abuse reporting requirements)
 - The state's MEP ethics and safety policies
 - The state's quality control procedures, such as the *prospective* re-interviewing plan

2. *Local.* The local action plan should build on the state's plan and should provide direction for local recruiters. In some states, particularly small states, the local MEP may use the state action plan rather than developing a local plan. The local plan should have ID&R objectives that support the state's objectives, as well as strategies, staff assignments, and timelines to meet those objectives. The local action plan could also include useful resources like:
 - Procedures that focus on recruiter safety (see below) and related contacts
 - A consolidated calendar that tells when to recruit in specific areas (including information like seasons for major crop activities, housing availability, school calendar)
 - Maps or directions to major employers, agencies, and schools
 - Who to contact at specific farms, agencies, or schools
 - Enrollment procedures for specific schools
 - Hiring procedures used by individual employers; and any Memoranda of Understanding(s) (MOU's) between service providers

3. *Individual*. The recruiter's individual action plan should build on the state and local action plans, should be detailed and specific, and should translate into a schedule or "to do" list for the recruiter within a specific timeframe (see the example in Appendix VI). The recruiter's initial action plan may be rather basic, but the objectives should evolve and improve over time. Year-round recruiters may work with their supervisor to develop an action plan or recruitment calendar. Part-time or summer recruiters may receive very specific instructions from their employer so they can start recruiting migrant children immediately. The local MEP should review the recruiter's action plan to make sure it is consistent with the project's recruitment priorities and the state action plan. Action plan recruitment objectives generally consist of the following four parts:
- What the recruiter will do
 - When the recruiter will do it
 - How the recruiter will do it
 - How the recruiter will measure success

The following are **sample** recruitment objectives:

- I will visit five agricultural or fishing employer(s) every month as documented by my activity log. (Note: The number of employers visited may vary by district and/or state).
- I will conduct employer surveys with at least six new growers in my recruitment area within the next 12 months as documented by the completed survey forms. (Note: The number of employers visited may vary by district and/or state).
- I will spend three days recruiting at the turkey processing plant in October, when they hire seasonal Thanksgiving workers, as documented by my activity log.
- I will implement one new idea from this manual each month as documented by the completed actions on my task list.

Again, note that the recruitment objectives listed above are only examples. It is very important to understand that while it is good to set recruitment objectives such as the examples listed above, the recruiter should NEVER set an objective that establishes a recruitment quota or specifies that more migrant children will be found next year than were found in the current year. For example, a recruiter should NEVER set a recruitment objective that requires finding five percent more children in the coming year than were found in the last year. Furthermore, if the recruiter's supervisor sets a recruitment quota, the recruiter should report the practice to the next level supervisor or the MEP State Director (see the *Sample Recruiter Ethics Guidelines* in Appendix VII). These kind of hard objectives or quotas are tied not to correct eligibility determinations but to annual increases in numbers. They therefore raise ready conflicts of interest that may not only create serious questions about the reliability of a recruiter's eligibility determinations, but also undermine the entire local or State's MEP.

The individual action plan can serve as both an evaluation of the recruiter's work and a time management tool. To evaluate his or her own work, the recruiter may wish to ask questions such as:

- Were all of the objectives (i.e., action items) completed?
- Were they completed on time?
- Were the objectives (and the recruiter's work schedule) revised as the recruiter learned more effective recruitment strategies?
- How can the objectives be improved to find all migrant children while making better use of the recruiter's time?

The recruiter may also wish to evaluate the strategies in the action plans by asking new migrant families and recruitment network contacts how they heard about the MEP and by tracking the promotional strategies to learn which ones have been the most effective. Updating the ID&R action plan should be an ongoing task.

Each time a recruiter is hired or re-assigned, it is an excellent opportunity to conduct the research needed to develop new local and individual ID&R action plans or to update existing action plans. The recruiter who is new to an area brings fresh thinking to the task and an interest in learning about the local migrant community. Supervisors should gather as much information as possible from departing seasoned recruiters. Supervisors should make sure data logs and contacts have been updated and should consider conducting an exit interview that makes note of any suggestions the recruiter has for improvements. This will help prepare for the next recruiter's action plan. If available, the recruiter should review state and local ID&R action plans to see what information already exists and talk to local MEP staff about whether any updates are needed. If there is no state or local plan, the recruiter should talk to local MEP staff about how past ID&R efforts were organized. Where action plans have not been developed, the recruiter's plan could become a starting point for local or state planning.

I look forward to our end of season debriefings. We celebrate our accomplishments and plan for the coming year.

Time Management. To maximize productivity and manage time wisely, the recruiter should work with an immediate supervisor. For example, the recruiter may plan to canvass a migrant camp and visit a migrant Head Start center located in the same area on the same day. Scheduling visits to several sites that are located in the same geographic area on the same day saves time and travel expenses. Some basic things the recruiter should consider when setting a schedule include the following:

Weekly/daily considerations:

- The best days/hours to work (early mornings, nights, weekends)
- The best times to visit migrant families, schools, and employers
- Which employers, farms, or growers to visit in the current week
- When to promote the program with community agencies

- When to be in the office to complete paperwork and follow up on leads
- How the work schedule can be changed when needed

Monthly considerations:

- When to submit daily recruiter logs and other paperwork to the supervisor
- Attending monthly recruiter meetings
- Whether all schools, growers, employers, and farms have been contacted for the current month

Annual considerations:

- The high recruitment seasons
- Activities during low recruitment seasons
- When and how often training is conducted
- When professional development should be scheduled
- When to take vacations

Locating Migrant Families and Youth

To find local migrant farmworkers, I follow the port-a-john trucks to the fields and post flyers about the program on the inside of the doors.

The recruiter's research and the recruitment network should help identify when and where migrant families can be most easily found. Some common recruiting sites include work sites, schools, community organizations, and migrant families' homes. Each of these recruiting sites is discussed below.

Employer-based Recruitment

To get my foot in the door when I visit a new employer, I bring along someone the employer knows and trusts.

The recruiter may find it productive to visit the employer's work site and interview migrant families in the fields, processing plant, or migrant labor camps. Depending on the history and the local MEP's relationship with a particular employer, the approach may differ. For example, is this the MEP's first contact with this agricultural employment site or does MEP have a pre-established relationship? To prepare, the recruiter may want to do the following:

- *Use research and the recruitment network.* The recruiter should use the previous research to determine which local employers are the most likely to employ temporary or seasonal migrant farmworkers or fishermen, including which employers have employed migrant workers in the past.
- *Meet with individual employers.* As discussed previously, if this is a first contact, the recruiter may wish to have the supervisor help establish the recruiter's credibility with migrant employers by sending a letter about the MEP and following it up with a phone call. This gives the employer advance notice that the recruiter will visit and provides information about the MEP. While an unannounced visit is sometimes the only course of action in order to reach an employer, attempting to provide advance notice is recommended when possible.

In whatever manner the encounter is made, when the recruiter does meet with the employer, the recruiter should:

- Introduce himself or herself; a firm handshake is common in the agricultural community.
- Determine their MEP knowledge.
- As appropriate, explain the purpose of the MEP.
- Determine if the employer has temporary or seasonal jobs.
- Solicit the employer's cooperation in recruiting migrant children.
- Determine which workers are the most likely to qualify for the MEP or to have a child or spouse who qualifies.
- Find out the best times to interview workers (e.g., provide information about the MEP and the upcoming recruitment visit by including it with their paychecks) and which languages the workers speak.
- Find out if there are any workplace requirements that the recruiter needs to obey (e.g., parking locations, farm or plant safety measures, where to meet workers).
- Schedule the recruitment visit.

- When meeting with key personnel, the recruiter should remember to keep it short, positive, and to the point.
- *Conduct onsite recruitment.* Onsite recruitment usually involves direct interviews with family and youth to determine eligibility (see Chapter 6 on *Interviewing Migrant Families and Youth*).
- *Follow up.* After the meeting, the recruiter should:
 - Thank the employer.
 - Discuss the results of the recruitment visit (e.g., how many migrant children were identified).
 - Solicit feedback on how the employer thought the recruitment visit went and whether any changes need to be made for future recruitment visits.
 - Ask the employer to inform MEP staff when new workers are hired who might qualify for the MEP or might have a child or spouse who qualifies.
 - Schedule future recruitment visits.
 - Request that employers put MEP contact information in new employee packets or allow the recruiter to hang posters in the employee break room.

School and Community-based Recruitment

I had a hard time getting a school to work with me, so I had my coordinator send the school a letter of introduction and call the school principal. The school was much more open the next time I visited.

The recruiter may find it beneficial to recruit during annual school enrollment periods or to participate in community health fairs or other community outreach efforts. When recruiting at these venues, the recruiter may find it useful to have families fill out “pre-qualification” forms to identify the parents who are the most likely to have children who are eligible for the MEP. If the pre-qualification form looks promising, the recruiter can interview the family immediately. Establishing a positive relationship with school personnel is very important. Many recruiters work with school registrars by having MEP surveys or pre-qualification forms inserted into the school’s new student enrollment packets. Promising surveys then get mailed to the ID&R office, allowing for the screening of potentially eligible families throughout the year. The local recruiter follows up with a phone call to further screen the family for eligibility details, and if eligibility looks good, sets an appointment to visit the family as soon as possible. To find possible leads, the recruiter may want to find out which children are enrolled in other school-based programs that often enroll migrant students, like the ESL program. Similarly, the recruiter should attend community service fairs where local service providers set up temporary intake offices in a single location to allow migrant families to sign up for a number of benefits and services at one time. As with agricultural employment logs and profiles, recruiters may find it useful to keep school profiles detailing the primary MEP contact at the school (registrar, guidance counselor, school nurse, main office secretary, etc.). When the recruiter maintains a contact log it establishes a record of communication and helps to maintain the relationship. Email is another great form of communication with school personnel.

Get a copy of the student handbook from all the schools in the area where you recruit. Read the handbooks and become familiar with the policies for such things as attendance, discipline, graduation requirements, and grading periods. Keep the handbooks for reference. Then you'll be prepared to help the parents when they have questions.

Residence-based Recruitment. Canvassing, or going door-to-door, is the primary form of residence-based recruiting. However, if there is insufficient preparation or research done before conducting a canvass, it may not be the most efficient method. For example, it can be extremely efficient to go door-to-door looking for migrant children in a migrant labor camp. On the other hand, it can be extremely inefficient to randomly go door-to-door in a large urban center. Through research and the recruitment network, the recruiter can often identify the most productive areas to canvass. For example, the recruiter is likely to find migrant children in housing near local farms, and in modest apartment complexes or local trailer parks where migrant children have been found in previous years. The recruiter may want to use the state's migrant student database to print off a list of children along with their previous addresses that have been eligible in the past to look for them as well as any new children who may be residing in the same area.

It can be useful to invite school personnel to participate in recruitment visits to break down barriers between the school system and migrant families. Moreover, it is often preferable for teams of recruiters to canvass together, especially in areas where large numbers of OSY might be found.

A good recruiter is prepared. Recruiters should always have a stocked toolkit on hand containing materials and resources relating to ID&R such as:

- Blank national COEs and pens (or a laptop computer or personal digital assistant (PDA) with an electronic national COE)
- A local map that can help identify promising areas in which to recruit
- Online georeferencing map or other directional guide
- The *Basic Migrant Child Eligibility Factors Chart* and the *Sample Interview Script* (see Appendix VIII)
- Business cards or a badge that identifies the recruiter as being employed by the MEP
- Brochures on the MEP
- Local school student handbooks
- Language dictionaries (e.g., English/Spanish)
- Important contact information (e.g., names and phone numbers for the recruiter's supervisor and co-workers, key school personnel, emergency contact information for local hospitals and police, etc.)
- Local resource guides (e.g., a list of local schools, social service agencies, adult education materials)

- School information (e.g., school bus schedules, enrollment procedures, school calendars)
- “While-You-Were-Out” doorknob hangers or sticky notes that include the recruiter’s contact information
- A U.S. atlas and list of state abbreviations to look up the spelling of city names when filling out the national COE
- Maps of Mexico and a state/city index to help identify migrant family origins and to help the recruiter look up the spelling of city names in Mexico when filling out the national COE
- A cell phone, walkie-talkie, or other communication device
- A whistle or other safety device

Each of the three main recruitment activities (i.e., employer-based recruitment, school and community-based recruitment, and residence-based recruitment) is effective in certain settings. Therefore, the recruiter should mix and match these approaches, depending upon which will be the most effective and efficient in the local community. For example, K-12 students are usually the easiest to locate, as they are a “captured” population who are likely to attend school. Parents bring the children to school to register, and elementary school-aged children, in particular, usually attend regularly. Networking at the school and getting referrals from school staff can be an effective and efficient strategy for recruiting these students. Pre-school children, on the other hand, may not have any connection to the school system unless a local school or other agency operates a daycare or preschool; thus, the recruiter may need to find pre-school children through networking with other service agencies, agricultural employers, or by canvassing in neighborhoods where migrant families often live. Finally, OSY, who are often teenagers, are usually found in the community where they live or work. Promotional activities combined with employer-based recruitment may be the best way to contact this hard-to-reach group.

Safety While Recruiting

Dogs have chased me on recruitment visits, so now I always check to be sure that they are chained. If they aren't chained, I stay in my car and call for someone to come out and get the dog before I get out of the car. I'm required to call my office twice a day so they know I'm safe.

The recruiter should always be alert to the surroundings and be aware of his or her personal safety and security. Driving down a country road after dark, entering a building in a dangerous part of town, coming across threatening dogs guarding a farmhouse, or being female in a camp full of males are just a few situations the recruiter may encounter. Many of these circumstances arise in any outreach job and some occur because of the rural nature of ID&R. Each MEP should have safety policies that are reviewed during the recruiter's initial training. In addition, many MEPs find it useful to meet annually with local law enforcement officers to review personal safety strategies. Planning, preparation, awareness, and common sense can be the recruiter's best defense. Experts on safety refer to an individual's "instincts" or "sixth sense" that warns of danger. If a situation does not "feel" right, the recruiter should rethink the visit and return another time. Safety is always the first priority of the MEP. No student enrollment opportunity is greater than a recruiter's personal safety. If the recruiter is in a dangerous situation, he or she should leave and return another time with additional support (recruitment team or agricultural employer). Using personal safety strategies such as those described below are important. States may come up with a range of safety measures. For example, some safety strategies may be best practices, others may be part of a safety system and finally, many states enforce safety protocols.

Best practices for recruiters include:

- Only enter migrant housing if necessary; most recruitment paperwork can be completed outside regardless of the season.
- Conduct pair or team recruiting visits whenever possible.
- Female recruiters can have a male outgoing message on their voicemail such as, "Hi, you've reached Jen and Jason, please leave a message," in order to deter unwelcomed voicemail and text message advances.
- Always have car keys readily accessible.
- Always carry a cell phone; 911 still works without a service provider and in many cases you can still text 911 with no reception.
- Consider carrying mace or pepper spray.
- Pay attention to instincts; recruiters should react appropriately if feeling unsafe.
- Pay attention to personal behavior; sometimes a recruiter's friendly behavior can give the wrong impression, especially if cultural differences are present.
- Notify farm employer or manager upon visiting farm worker housing.
- Consider taking a self-defense course.

Best practices for systems include:

- Pre-schedule farm visits whenever possible.
- Use a buddy information system with colleagues to keep everyone informed of when and where the recruiter is going to be while conducting recruitment efforts.
- Provide training on proper responses to uncomfortable advances.
- Provide training on how to report incidents and provide samples of previous reports to make new staff aware of potential situations.

Protocols:

- Do not distribute personal phone numbers of colleagues (or others) without their permission.
- Dress code—recruiters should wear MEP t-shirts and/or MEP vests if possible.
- Maintain a schedule with information on when and where recruitment efforts will be taking place.
- Do not recruit after dark unless pre-scheduled and accompanied by a buddy.¹

The information provided above is intended to be utilized as a guide to help ID&R administrators and recruiters come up with their own safety measures. While serious safety situations are a rarity in the MEP, unfortunately they do occasionally occur. The best defense against danger is being informed, having a proactive safety plan, and knowing what to do if a problem does occur.

Communication. The recruiter should always carry a cell phone with emergency numbers in the speed dial and have a backup plan for rural areas that may not have cell phone reception (recruiters who do not have a cell phone may want to invest in a walkie-talkie or other communication device). Before going on the road, the recruiter should tell a responsible coworker the day's visitation schedule and an expected time of arrival back at the office or home. When recruiting at a work site, the recruiter should check in with the farmer or crew leader before beginning recruitment activities. The authorities should be notified if the recruiter does not arrive at a particular destination on time and cannot be reached by telephone.

Local Knowledge. The recruiter should plan visits with safety in mind. Knowing which labor camps or neighborhoods may be cause for concern or what apartment complexes should not be visited alone may keep the recruiter from entering a potentially dangerous situation. The recruiter should consider which areas are best visited during daylight hours and whether a team, rather than an individual, should visit a particular apartment building. This type of information, which may be shared by local school personnel or community agency staff, should never be ignored. The recruiter should also be aware of the locations of local police stations, hospitals, and businesses that are open late. It is also important that the local community is aware of the MEP and the recruiter. Wearing a badge that has

¹ University of Vermont Extension, Migrant Education Program, *Identification and Recruitment Safety 101*, (Berlin, VT, 2011).

the recruiter's name and place of employment can establish credibility and identity in case of an emergency. The recruiter should also be careful not to share too much personal information, particularly his or her home address or home telephone number.

Transportation. Recruiters should make sure that car doors are locked when not in the vehicle and should also keep valuables out of view. The recruiter's car should be properly maintained and mechanically sound. Having a reliable car with a full tank of gas is a necessity when driving in rural areas. When possible, the recruiter should choose well-traveled roads and avoid shortcuts through isolated areas. The recruiter should have good maps (traditional or those downloaded from the Internet) to avoid getting lost. Many recruiters are issued GPS units or other navigation devices to aid in recruitment safety and efficiency. Emergency items (car jacks, flares, blankets, matches, flashlights, candles, water, a shovel in colder climates, etc.) can help the recruiter stay safe until help arrives in the case of an accident or an emergency.

Conclusion

The most effective recruiters plan their work and follow their plan. Gathering information on the migrant community before beginning recruitment activities and using that information to develop an individual action plan can save both time and effort. Furthermore, individual action plans help recruiters set priorities and manage time efficiently. The recruiter should consider which recruitment strategies are the most likely to be successful when developing his or her own recruitment action plan. Safety factors must always be considered when planning work in the migrant community.

Once the recruiter has identified areas that are likely to have migrant families, the next step is to interview individual families and youth, using the *Sample Interview Script* provided in Appendix VIII. Chapter 6 provides an interview protocol, discusses the interview process, and provides lessons learned from interviewing.

Recruiter Checklist

Chapter 5: Developing Action Plans & Contacting Families

Did you?

- Develop an action plan?
- Canvass areas where concentrations of migrant children and their families are likely to be found (e.g., migrant labor camps, major local employers)?
- Make personal safety provisions (e.g., carry a cell phone with emergency numbers on speed dial, have a backup plan for areas that do not get cell phone reception, leave a visitation schedule with a responsible coworker, visit potentially dangerous areas during daylight hours and with a partner or team, know the locations of local police stations and hospitals, have reliable transportation, use well-traveled roads)?

Chapter 6. Interviewing Migrant Families and Youth

The Recruiter as Interviewer

Recruiting requires a great deal of knowledge, skill, and sensitivity. In particular, the recruiter needs to thoroughly understand the MEP child eligibility requirements and be able to ask probing, yet not leading, questions to make informed decisions about whether a child or youth qualifies to receive MEP services. Furthermore, the recruiter needs to solicit this information without offending the migrant family or youth. This chapter addresses how the recruiter prepares to interview migrant families and youth, as well as how the recruiter should conduct the interview.

Is interviewing a science or an art? Is it the science of understanding rules and regulations, completing paperwork correctly, analyzing data, and making accurate eligibility determinations? Or is it the art of talking to people one-on-one to elicit information that may be very personal? Interviewing is both. The recruiter must strike a balance between having a relaxed conversation and gathering the very specific information needed to determine child eligibility.

Conducting a thorough interview and accurately documenting the information collected is key to determining a child's eligibility for the MEP. Therefore, in addition to the national COE, the official record of the state's eligibility determination for each individual child, many states also utilize a supplemental interview form to gather supporting information. For this purpose, a *Sample Interview Script* has been provided in Appendix VIII. This document will guide the recruiter through the actual interview process. This chapter will walk the recruiter through the process immediately before visiting prospective families or youth all the way through what to do after completing the interview.

Sample Interview Script

To determine whether a child or youth is eligible for the MEP, the recruiter needs to interview the migrant worker or another responsible adult to obtain information regarding eligibility. Supplemental interview forms guide the recruiter through a series of questions to create a structured, yet comfortable, conversation to draw out the information needed to make a preliminary eligibility determination. It is the *recruiter, not the migrant worker*, with the help of other MEP staff, who makes the preliminary eligibility determination of whether a child qualifies for the MEP. In many states, it is the ID&R coordinator or SEA director who makes the final eligibility decision. The recruiter should always remember his or her role.

While a supplemental interview form is a useful tool in determining child eligibility, it is not all-inclusive. There are situations where the recruiter may need to ask different questions to address a particular interview situation. However, supplemental forms provide two purposes: a starting point for new recruiters to understand the basic questions to determine child eligibility, and a supporting record of the underlying information the national COE is designed to collect. The new recruiter may find a script more useful than a veteran recruiter. However, the veteran recruiter should consider

making a script part of the standard interview process to ensure that he or she is asking all of the key questions through the process of the interview.

The *Sample Interview Script* example in Appendix VIII is formatted to guide the new recruiter through an eligibility interview. It is organized into six sections that reflect the interview process. The sections, which are named for the tasks the recruiter should complete, are:

1. Lay the Groundwork for the Interview
2. Transition to the Interview
3. Gather Information on Child Eligibility
4. Transition to the Confirmation Process
5. Confirm Responses
6. Close the Interview

The first two sections are introductions and explanations. The third section is what could be referred to as the eligibility interview, where the recruiter asks questions of the family or youth to determine eligibility for the MEP. After gathering information through these questions, the recruiter transitions to a summary and confirmation of the eligibility information. Finally, the recruiter closes the interview and leaves the family or youth.

Each section of the *Sample Interview Script* has a title that is centered on the page and a series of basic statements or questions (written in regular typeface) that the recruiter should ask. Instructions to the recruiter and notes are written in italics or are provided as footnotes at the bottom of the page; the recruiter should not read these aloud since they are meant to guide the recruiter in completing the interview. Where a question can be stated in several ways, options may be provided in parentheses. The script also provides columns that the recruiter can use to mark whether the family or youth answered “yes” or “no” to a particular question, and blank space to take notes on the interviewee’s responses.

The third section of the *Sample Interview Script*, which is entitled “*Gather Information on Child Eligibility*,” contains questions that are used to determine child eligibility. The recruiter should ask each numbered (i.e., basic) question, because these questions will determine if the child meets each basic eligibility requirement for the MEP. When using the *Sample Interview Script*, the recruiter should keep the following in mind:

- If the numbered questions do not draw out the information the recruiter needs, the numbered questions are followed by probes or follow-up questions, lettered a-z, that the recruiter can use to get at the same information in a different way, or to ask for additional information that the recruiter may need to confirm, clarify, or supplement the initial response.
- The recruiter may or may not need to ask follow up questions depending on how the interviewee responds to the numbered question.

- If a recruiter gets a response to a numbered question that would make a child ineligible for the program, the recruiter should make sure the interviewee understood the question before terminating the interview. The recruiter can restate the question in another way, using one of the additional questions provided, being careful not to lead the interviewee or make it appear as if there is a “right” answer.
- Depending upon the particular family or youth’s situation, some follow-up questions may not appear to be directly related to the numbered question, but they elicit information that will support the response to the numbered question.
- Space is provided on the *Sample Interview Script* form to make notes.

The third section of the *Sample Interview Script* is broken down into the following basic child eligibility factors:

1. **AGE:** The child is younger than age 22.
2. **SCHOOL COMPLETION:** The child is eligible for a free public education under state law. For example, the child is *not* a high school graduate or does *not* hold a high school equivalent certificate.¹
3. **MOVE:** The child has moved across school district lines² in the past 36 months on his or her own, or with or to join an agricultural or fishing worker. And, the move was a change, from one residence to another, due to economic necessity.
4. **PURPOSE OF MOVE:** The purpose of the worker’s move was to obtain (or seek) qualifying work.
5. **QUALIFYING WORK:** The worker sought or obtained temporary or seasonal employment in agricultural or fishing work.

The *eligibility factors* are based on the definition of a migratory child found both in the statute and regulations. The next chapter, *Determining Eligibility*, will discuss how to interpret the interviewee’s responses.

The new recruiter is encouraged to complete the *Sample Interview Script* each time an interview is conducted. Furthermore, the new recruiter should keep the completed script to document how the preliminary eligibility determination was made. The completed *Sample Interview Script* is a good tool for a supervisor and a recruiter to use to discuss individual child eligibility determinations.

Variations of Supplemental Interview Forms. While the *Sample Interview Script* described above provides a very detailed guide for the new recruiter, other supplemental interview forms may be

¹ The recruiter should find out which older children are still entitled to a free public education in his or her state. If a question arises (e.g., the child has a secondary school degree issued by another country or has received a certificate of completion in lieu of a diploma), the recruiter should find out from state officials whether the child is entitled to continue to pursue a high school diploma in that state.

² For a state that is comprised of a single district; has moved from one administrative area to another within such district; or resides in a school district of more than 15,000 square miles and migrates a distance of 20 miles or more to a temporary residence to engage in a fishing activity. (This provision only applies to Alaska.)

more condensed for a traditional interview situation. The purpose of supplemental interview forms is to provide a recruiter with the questions needed in order to consistently obtain sufficient information to make an eligibility determination for a migrant child, youth, and family.

While no tool can meet the needs of every state, every recruiter, and every interview, states may wish to adopt a supplemental interview form to address state initiatives or to meet quality assurance goals. In some states, the recruiter may need to collect additional information that is required for the Consolidated State Performance Report (CSPR) or for special program services, or may want to collect information on children's home language, learning skills, or medical history including immunizations. Finally, the state may want to revise a supplemental interview form so it can be used to conduct re-interviews. Although recruiters are not required to use supplemental interview forms, every interview should address all of the basic child eligibility factors discussed earlier.

Asking Screening Questions. After the new recruiter has conducted several interviews and has gained experience with the structure and questions, he or she might want to select a few questions, as briefly mentioned above, that can be used to screen families and youth. This practice helps by quickly screening whether anyone in the household meets the primary eligibility criteria, thereby warranting a full interview. Although the most reliable way to determine which children or youth are eligible for the program is to conduct a full interview with every prospect, because of time constraints, the recruiter may decide to focus on those children and youth who are most likely to be eligible. The recruiter should recognize that using screening questions will mean that some eligible children are likely to be missed, so the recruiter must weigh the need for efficiency against the importance of identifying *all* eligible migrant children.

If the recruiter uses screening questions, he or she should not make a preliminary eligibility determination without asking all of the numbered questions on the *Sample Interview Script*. The type of friendly conversation that often occurs during an initial screening will not give the recruiter enough information on each of the basic child eligibility factors to make a reliable child eligibility determination. During the full interview, the recruiter will need to ask enough follow up questions to gather all needed information. Asking screening questions may help the recruiter use time wisely by only conducting interviews when it is likely that a child or youth will be eligible for the MEP. However, screening questions cannot replace a full interview.

Changing the order of Questions. Another adaptation or modification that a recruiter might consider is changing the order of the questions on the supplemental interview forms to get at the questions that would be most likely to disqualify a particular child or youth first. For example, if the recruiter is interviewing a mother who has three young children with her, the recruiter might find it more productive to begin the interview by asking whether the family has moved within the last 36 months rather than by asking the ages of the children. If the family has not moved, there is no reason to proceed further with the interview. Also, the recruiter may want to change the phrasing of questions to use language that local families might be more familiar with or may want to translate the questions into the family's native language. Although recruiters have the flexibility to modify the order of questions, recruiters must examine the basic eligibility factors to determine whether a child is eligible for the MEP.

Visiting Families or Youth

I don't jump into a full interview too soon. I let the family see me around before I do a full interview.

Although the interview is the most important interaction in ID&R, there is important preparation work that the recruiter must do to make the interview successful. The state or local program may require the recruiter to complete some or all of the following activities before, during, and after interviewing families and youth.

Before the Visit. When the recruiter makes a home visit, often without an invitation or advance notification, the recruiter is stepping into the world and culture of the migrant family. Therefore, it is important for the recruiter to make a good first impression and respect the dignity of the individuals and families being visited. The following are general steps the recruiter may wish to follow prior to visiting a family:

- Pre-screen families or youth prior to the visit, if possible. For example, follow up with families or youth who have completed either a school or employer survey such as the ones found in Appendix III and appear to be eligible for the program or have a child or spouse who is likely to be eligible. If that is not possible, the recruiter can call the family prior to the visit or get information from others who know the family or youth.
- Develop a schedule of who to visit each day and get directions to the family or youth's home or workplace. If interviews will be conducted at a housing unit or work site, contact the housing unit manager, farm owner, plant manager, etc. first to explain the reason for the visit and ideally obtain permission to conduct the interview (see Identifying Important Information Sources and Building Relationships and Gathering Data in Chapter 4).
- Determine whether an interpreter is needed and, if so, make suitable arrangements. Bring a copy of the national COE that is translated into Spanish if that is the family's native language. Find out as much as possible about the family or youth's needs prior to the visit so that the recruiter can bring useful resources. For example, if an older child did not complete high school, the recruiter may want to bring information on a local high school equivalency program.
- Print out information on the family from the state migrant student database, if available, such as any COE data that is in the system or a list of courses the child has taken that are only partially complete.
- Dress neatly, but not too formally, so that the family feels comfortable.
- Give a colleague a copy of the day's schedule, complete with locations, approximate times, and when the recruiter expects to return to the office or home (see Safety While Recruiting in Chapter 5). Notify the office or a co-worker if plans change.
- Print a copy of the *Sample Interview Script* and the basic child eligibility factors to be addressed during the interview.

- Bring any materials the recruiter will need to complete the national COE and any other forms required by the state. For example, some states require the completion of a needs assessment for all families or an OSY profile for every OSY enrolled into the program. Some states use a paper copy of the national COE form and require a pen. In other states, tablets, smartphones or laptop computers may be used (see suggestions for what to take on a recruiting visit in *Contacting Migrant Families and Youth* in Chapter 5).
- Take time to get organized before conducting each interview. Fumbling for promotional materials or COEs makes the recruiter look ill prepared and can reflect poorly on the MEP.

During the Visit. As stated previously, during the interview, the new recruiter should follow the *Sample Interview Script* (see Appendix VIII). Supplemental forms provide detailed questions that the recruiter should ask; however, the following are additional guidelines to follow when interviewing:

- *Observe the surroundings.* The recruiter should always be observant about the family or youth's environment. For interviews that are conducted at the home or workplace, the recruiter should look for clues that may require the recruiter to ask additional questions to help determine if the child is eligible for the MEP. For example, seeing that a migrant mother is operating a well-established day care center out of her home might alert the recruiter to ask more questions about whether the family has moved within the last three years. Observing that a father has a fleet of trucks with the name of the family's construction business on them in the driveway should alert the recruiter to ask questions regarding the economic necessity of the migrant agricultural or fishing work to the family's livelihood. The recruiter should use all available information to ask the right questions to accurately determine the child's eligibility for the MEP.
- *Make introductions and explain the purpose of the visit.* The recruiter should begin by introducing himself or herself and explaining the program the recruiter represents and the reason for the visit. It is not necessary to go into great detail about MEP services, but the recruiter should provide enough information to put the interviewee at ease so the recruiter can gather accurate information. A parent or youth may feel less apprehensive and may be more forthcoming if he or she understands the reason for the interview. The recruiter may also want to point out that he or she is not selling anything; the MEP is free for eligible children and the information they provide is confidential.
- *Find common ground.* The recruiter will need to think about how to build a rapport with migrant families. Saying things such as, "I see we both have three children" or "You've lived in Texas; I've been to Texas several times and really liked it" may relax the interviewee and keep the conversation going as the recruiter obtains the required information. Making friendly conversation with the children or admiring a pet or a child's artwork may also make parents feel more comfortable.

Use a conversational tone. This will help put the interviewee at ease and will make the recruiter more likely to obtain accurate information. Administrators often try to hire recruiters who are friendly, non-threatening, and if possible, from similar cultural backgrounds so families and youth feel comfortable talking with them. Being too “business-like” or asking probing questions too quickly can make a family or youth feel uneasy and unwilling to share information. Having an understanding of possible cross cultural differences will help to set the proper tone of the interview.³

- *Take notes.* The recruiter should always take notes during the interview rather than relying on memory. These notes, which can be filed with the completed national COE or on a supplemental interview form, become important when an eligibility determination is questioned or when a third party requests additional information on how the decision was made (e.g., as in the case of a quality control re-interview, or in an appeal by a parent).
- *Practice active listening.* The recruiter only gets the information that is needed when the interviewee is talking. Therefore, the recruiter should be sure not to dominate the conversation. The recruiter should use active listening skills, including techniques like the following:
 - Focus on the speaker.
 - Sit near the speaker.
 - Lean forward in an engaged pose.
 - Restate the speaker’s key points.
 - Summarize the conversation.
 - Ask relevant questions.
 - Show interest through facial expressions and gestures like nodding.
 - Let the speaker rest after talking.

Interrupting speakers, dominating the conversation, or even coaching answers from a parent or youth is not only a sign of disrespect, but it can lead to faulty eligibility determinations.

- *Repeat or reword questions.* The recruiter should feel comfortable asking a question a second time or approaching it from a different angle. For example, a recruiter might ask, “Has your oldest daughter graduated from high school?” “Has she received a GED?” “Did she take a test and receive a certificate that said she passed high school?” Rewording a question may help the interviewee understand what information the recruiter is seeking.
- *Answer questions or make a note to follow up.* If the family or youth asks a question that the recruiter cannot answer, the recruiter should not be afraid to say, “I do not know the answer to that, but I’ll be glad to find out for you.” It is much better for the recruiter to admit not knowing something than to give the wrong answer. Writing

³ Texas Education Agency, *2011-2012 Texas Manual for Identification and Recruitment of Migrant Students*, (Austin, 2011).

down any questions or concerns the family or youth might have and following up with them later will help build the recruiter's credibility within the migrant community.

- *Ask for additional information or documentation.* There are five scenarios in which the recruiter is advised to ask more questions or to get additional documentation. They are:
 - The facts are unclear. An interviewee may give conflicting or unclear answers because of fear or stress, an inability to recall specific information, language issues, or other unintentional reasons. For example, one family member may say the family moved in the spring, and another family member may say they moved in the summer. The recruiter should ask for more information to clarify the date of the move. Another example is where language issues prevent the recruiter from getting clear responses to eligibility questions (e.g., the person being interviewed speaks a language that is not typically spoken in that area and the local project is unable to find a good translator). Again, the child **should not** be enrolled until the MEP has enough information to determine if he or she is eligible.
 - It is not clear that the worker is seeking qualifying employment. If the worker moved to find work that the state has not qualified previously, it may not be clear whether the work meets the definition of being agricultural or fishing or of being temporary or seasonal employment. In this case, the recruiter would need to collect enough information to allow the state to determine if the work qualifies for purposes of the MEP.
 - It is a high-risk area or an area that has been a problem in the past. Some audits discovered cases in which recruiters incorrectly identified children as being eligible for the MEP. These children were misidentified because the recruiter did not properly apply the eligibility requirements in areas such as the economic necessity of the move and the temporary nature of the employment. These are areas in which the state MEP should be particularly watchful. For example, if a recruiter has completed a number of national COEs recently where the worker claimed to look for work but did not obtain the work, the recruiter should document such information as where each worker sought work, why the work was not available, whether there was an environmental condition that reduced the number of workers needed (e.g., flood, crop failure, hail), whether the worker has done this type of work before, etc. It is important to be especially vigilant in documenting eligibility in high-risk areas such as these.
 - The recruiter suspects that the family has not been truthful. In some cases, a family may say whatever they need to say to get their child a desired MEP service (e.g., extra tutoring). For example, a worker may claim to have moved to another state for qualifying employment during a specific time period. However, the recruiter may have viewed records that show the children in attendance at the local school or seen the worker in town during that time. In this case, the recruiter should ask for additional information such as proof of employment that may include verbal confirmation from the employer, a copy of a pay stub, or a

copy of an employment application. The recruiter might also speak with school personnel to find out if the child missed any school during the time the worker claimed to have moved to another state.

- If there is a question regarding economic necessity. If a move was of an extremely short duration of time, for example a few days or less than one week, it may be questionable whether the family moved due to economic necessity. The ED considers economic necessity to mean the worker moved either because he or she could not afford to stay in the current location or went to a new location in order to earn a living. Therefore, in situations such as short term moves or other visible cues such as a family business or a lavish home, the recruiter must probe further. The key is to figure out whether or not the family or youth would have moved regardless of whether there was agricultural employment available. In cases where economic necessity may be questioned, the recruiter should clearly document why the move did or did not qualify.

Additional documentation should only be requested when the information is needed to determine a child's eligibility for the MEP, since parents may view these requests as unnecessary and intrusive. The recruiter should talk with a supervisor to decide if additional documentation is needed and, if so, what type of documentation to request (more information on documentation is provided in Chapter 7). If the recruiter and supervisor are not able to determine if a child is eligible for the MEP because the parent is unwilling to provide additional documentation or there are still questions about the child's eligibility after the recruiter reviews the additional documentation, the child **should not** be enrolled in the MEP.

- *Confirm the information on the national COE and get the form signed.* The recruiter should review the COE with the person who was interviewed to make sure that everything recorded on the form is accurate. When you review the information, the interviewee may make corrections or remember additional details; the recruiter should take the time to get it right. The recruiter should summarize the information gathered from the interview and repeat it back to allow the interviewee to make corrections if necessary. Once any needed corrections have been made to the national COE, the recruiter can then ask the interviewee to sign the form to verify that he or she provided the information and that it is true to the best of his or her knowledge. The recruiter may have permission slips or other forms that need to be signed as well.
- *Thank the interviewee and ask for referrals.* The recruiter should thank the interviewee for his or her time and ask whether there are other farmworkers or fishers who live in the local community who might be eligible for the program or have additional family members or co-workers who might be eligible.

I'm careful not to promise the family that their child will receive services because my state doesn't get enough money to serve every child. I'd rather tell the family that I will find out whether their child can get extra services so I don't promise something I can't deliver. I want migrant families to be able to trust me.

After the Visit. After the recruiter has completed the interview portion of the visit, he or she should do the following:

- Check the national COE to make sure it is complete, clear, signed, and correct (see the sample national COE Review Checklist in Appendix XII).
- If needed, consult with the translator to verify the information on the national COE and observations regarding the interview.
- Make a note of any observations about the family or youth that may assist in making the final eligibility determination.
- If appropriate, thank the housing unit manager, farm owner, or employer for being cooperative.
- Follow up on any promises made to the family during the interview.
- With the interviewee's permission, contact community agencies and provide them with referral information so they can help address any needs the family may have that are outside of the scope of the MEP.
- Where required by the state or local program, record the interview in an activity log (i.e., a record of how the recruiter uses his or her time) and complete any other required paperwork.
- If the recruiter gathered any new or updated information from the family or youth, enter that information in the state or local migrant student database.
- Avoid sharing private information about the family that came out of the visit. Respecting confidences is a way of gaining the respect and trust of the family. Much of this information is also protected by privacy laws.

Difficulties While Interviewing

The recruiter may encounter any number of difficulties during an interview. While it is impossible to anticipate every possible issue a recruiter might encounter, some of the most common are discussed below.

Resistance. A migrant family or youth may refuse to be interviewed or may not want to disclose information about their employment, particularly if the family or youth is not familiar with the program. While there are many reasons why a recruiter could face resistance, one reason is that a number of recent immigrants and farmworkers are uneasy about providing information to a government representative for privacy or other reasons. It is important that the recruiter assure the interviewee that the national COE will only be used to document the child's eligibility for the MEP and that the MEP does not collect information on immigration status of a family or individual. By explaining the MEP's basic purpose, the recruiter may be able to persuade the family to allow the recruiter to interview them. The recruiter may also ask a family who has been served by the MEP to talk with the new family. Many times a resistant migrant family or youth will become more

cooperative after talking with a satisfied parent or other OSY. Another strategy is to give the family time to think about the request and come back later.

To overcome resistance, it might be helpful for the recruiter to make the following points:

- A family or worker’s immigration status is not a factor in determining eligibility for the MEP.
- In the U.S., all children are entitled to receive a K-12 education, regardless of their immigration status. In fact, each state has compulsory school attendance for children who are within a specific age range⁴.
- The state is required to look for all children who are eligible for MEP services.
- The MEP is a supplemental educational program that helps migrant children who are struggling to keep up in school due to factors such as a lack of educational continuity, lost instructional time, difficulty adjusting to a new school, lack of educational support in the home, health issues, and access to services.
- Even if a child does not need help at this time, the family should know about the MEP for future reference.

The recruiter does not need to mention all of these points if the family is comfortable with sharing information or already knows about the program.

Assumptions and Judgments. The recruiter is susceptible to making assumptions and judgments about people he or she encounters that may make interviewing difficult. Some common assumptions the recruiter may unintentionally make include those found in Table 1.

⁴ Digest of Education Statistics, Age range for compulsory school attendance and special education services, and policies on year-round schools and kindergarten programs, by state: Selected years, 2000 through 2010 , [online data spreadsheet], available at http://nces.ed.gov/programs/digest/d10/tables/dt10_174.asp (January 3, 2012).

Table 1. Eligibility Interviewing Assumptions and Facts

Assumption	Fact
Every child in a family qualifies for the MEP.	There are times when one or more children in a family may not be eligible for the MEP. For example, a child may have been born after the family made the qualifying move or an older child may already have completed high school.
The children moved with the worker.	In some cases, a worker may move alone, leaving the children with a spouse or grandparent. In these cases, the children are not eligible for the MEP because they did not move. Also, it is possible some of the children moved and others did not.
All workers at a particular job-site qualify.	Some sites have both permanent and temporary or seasonal jobs. The recruiter should make sure that the job the worker sought is temporary or seasonal.
All migrants are Latino (or some other ethnic group).	While the majority of migrant workers nationally are Latino, migrants have been identified in every major ethnic group.
All Latino immigrants are migrants.	There are many Latino immigrants who do <i>not</i> meet the eligibility requirement for the MEP.
If the family's most recent move was not to find qualifying employment, they do not qualify.	Migrant families may qualify for the MEP based on any qualifying move they made during the preceding 36 months. The qualifying move does not have to be their most recent move.

The recruiter may unconsciously make judgments about individual families or youth that affect the outcome of the interview. For example, over time the recruiter may become aware that some families are more or less respected by other members of the local migrant community. The recruiter should be careful not to base eligibility decisions on assumptions or judgments formed by others, but rather look objectively at the facts. Even if the recruiter is uncomfortable with a particular family or youth's lifestyle or behavior, the recruiter cannot factor these feelings into the eligibility decision. The recruiter's role is not to judge a family or youth, but rather to make objective eligibility determinations for the MEP.

Language and Culture. The recruiter may come in contact with unfamiliar languages or cultural norms. If the recruiter does not speak the family's language, he or she may overcome linguistic differences with the use of an interpreter. When using an interpreter, the recruiter should remember to communicate with the family, not just the interpreter. Avoiding slang and long statements can make interpretation easier. The interviewee should be reminded that talking slowly and pausing when responding will help the interpreter. Cultural challenges can be more difficult to overcome. However, most people generally appreciate sincere attempts to be cordial and respectful. Having sincere concern for the welfare of the family and children will also help to avoid awkward cultural misunderstandings.

Distractions. The recruiter should be aware that distractions can diminish the quality of an eligibility interview. To increase the reliability of the interview, the family or youth should be in a comfortable environment with limited distractions. For example, a recruiter that interviews a worker at the doorstep of the home—with cars passing, children playing, and dogs barking—may not get accurate information or may not record the information accurately. The recruiter should be aware of the surroundings, and if there are too many distractions, the recruiter could ask screening questions, but wait to do the full interview at a more convenient time. If appropriate, the recruiter could also suggest moving the interview to a more accommodating space.

Leading Questions. Because the interview is critical to determining the child or youth’s eligibility for the MEP, the recruiter should avoid asking questions that lead families to give vague or untruthful answers. Leading questions can often be answered by “yes” or “no” responses and prompt the interviewee to give a particular answer. On the other hand, open-ended questions prompt the interviewee to provide more information than simply yes or no. In the first example below, “you moved here to work in agriculture, right?” the phrasing makes it appear that “yes” is the correct response. Rephrasing the question to “why did you move here?” allows the interviewee to provide various reasons without having a predetermined answer in mind. Below are several examples of leading questions that the recruiter should avoid, along with suggestions on how to rephrase them to be open-ended.

Table 2. Comparison of Open-Ended vs. Leading Questions

Ask open-ended questions...	DO NOT ask leading questions...
Why did you move here?	You moved here to work in agriculture, right?
What kind of work were you looking for? How did you know this type of work was available?	Did you move to obtain <i>any</i> type of agricultural work?
Has anyone in your family moved recently? When did they move?	You have moved recently, have you not? Say, within the past 3 years?
How long has your family been living in [name of current home town]? Did you ever travel anywhere else?	You know we have a great summer program for children who have moved. I will bet your kids have moved in the last few years, have they not?

The recruiter should not tell the interviewee the MEP eligibility requirements before the interview begins as this might inadvertently affect the interviewee's responses. Instead, the recruiter should ask questions similar to those in the *Sample Interview Script* in order to obtain accurate information.

Chronological Confusion. Experienced recruiters often report that it is easier to get a worker to tell *what* was done than *when* it was done. For example, a worker may recall having worked at a chicken processing plant, but may have trouble remembering the exact start date. Many people have trouble remembering specific dates; this can be even more difficult for migrant families who move frequently. It is critical that the recruiter get the most accurate date possible since the child or youth must have moved within the preceding 36 months to be eligible for the MEP.

To help the worker place the event in time, the recruiter may wish to:

- Review a calendar with the worker and ask the worker to point to the date of the move.
- Ask about the weather during the time the worker moved or obtained the agricultural or fishing work.
- Help the worker recall important news, school, or family events and try to determine if the move happened before or after that event.
- Ask the worker to recall the ages or grade levels of the children at the time of the move.
- Check with other family members.
- Ask to see pay stubs or school records.⁵

If the family has previously qualified for MEP services, information in the MEP student database or MSIX may help place the family or youth's move.

Contradictions. During an interview, a family may give answers that appear to be contradictory or inconsistent with what the recruiter has observed. For instance, the recruiter may observe that the family runs a thriving construction business even though the parent says agricultural work is an important part of the family's livelihood. If a situation is unclear or if the recruiter is not satisfied with the answers that the interviewee provided, the recruiter should tell the interviewee that he or she has to consult with a supervisor before determining if the child or youth is eligible and that he or she will inform the family of the supervisor's decision. A family or interviewee may feel pressure to give false or exaggerated information for a variety of reasons: to qualify for services, to please a friendly recruiter, to appease another family member, or to compensate for not knowing or remembering the answers to certain questions. The recruiter should be aware of these motivations and clarify any information that does not appear to be accurate. More information on this topic is found earlier in this chapter; material on falsification of information by the recruiter is found in the next chapter.

⁵ Floyd J. Fowler, Jr., *Improving Survey Questions: Design and Evaluation*, (Thousand Oaks: Sage Publications, Inc., 1995).

Premature Determinations. The recruiter should avoid telling the interviewee whether the child or youth is eligible for the MEP during the initial visit. There may be circumstances or issues that the recruiter did not consider during the interview that may later affect the eligibility determination. For example, the MEP staff person who reviews the national COE may question whether the work that the family does is temporary or may know something about the family that might affect the child's eligibility (e.g., the child did not move with the parents to do agricultural work). This additional information could change the recruiter's initial eligibility determination.

Similarly, the recruiter should avoid telling the interviewee that the child or youth will receive MEP services. The MEP is not required to serve every eligible migrant child. In some areas, there may not be enough migrant children to justify the cost of starting a program. In others, an eligible child may not be served because there are other eligible children who have greater needs. Funds are limited and local programs are often forced to make tough decisions. Families often ask what kind of services their children will receive, and the recruiter may be tempted to list all the services the local program provides. However, the recruiter should keep in mind that not *all* eligible children will receive *all* services. Therefore, while most programs assess migrant children and do their best to deliver the most appropriate services, there is no guarantee that every child will be served.

The recruiter should avoid the uncomfortable and unpleasant position of having to return to a family to inform them that there has been a mistake and their child is not eligible for the MEP and will not receive promised services. The recruiter should inform the family that others need to review the national COE before a final eligibility determination is made, and that someone from the MEP will notify the family of the outcome.⁶

Lessons Learned: Interviewing Migrant Families and Out-of-School Youth

In the fall of 2004, most states re-interviewed a sample of children who had been determined to be eligible for the MEP as part of a National Re-Interview Initiative. Through this initiative, there were a number of lessons that were learned about interviewing migrant families and youth. Some of those lessons are listed below.

The Role of the Recruiter. The recruiter may encounter families who are living far below the poverty level and who have great needs. Regardless of the level of poverty the recruiter finds in a home or shelter, the recruiter cannot confuse empathy for the family with the duties of the job. The recruiter should be careful not to perceive himself or herself as having the power to decide which children are eligible to receive services and which ones are not. Furthermore, the recruiter cannot use the MEP as a way to "level the playing field" by occasionally making a questionable eligibility determination to help a particularly deserving family. While it might feel good to be able to help a deserving family, the role of the MEP recruiter is to identify and recruit eligible migrant children, not children in need.

Moreover, for families that have domestic problems, there are social organizations that can help them with issues like domestic violence, drug abuse, child abuse, or neglect. The recruiter may not

⁶Massachusetts Department of Education, Migrant Education Program, *Massachusetts Identification and Recruitment Manual*, (Wilmington, MA, 2010), 15-16.

feel comfortable giving unsolicited information about these services to a family, but he or she should be aware that these services exist and should provide the information if necessary. In addition, the recruiter should learn the local, district, and/or state policy with regard to when and how to report suspected cases of child abuse and neglect.

Quality Control Procedures. Routine quality control checks are important for catching eligibility determination errors. The 2004 National Re-Interview Initiative resulted in ED’s issuance of regulations that mandate quality control procedures nationwide. Annual prospective re-interviews are designed to catch errors prior to reporting the number of migrant children in the state. An ongoing random sampling of students allows concrete training opportunities when errors are found. It also leaves less room for intentional inaccuracies from recruiters when they know ahead of time a family may be called for a random re-interview.

Services Vary. States and school districts offer a variety of different types of services through the MEP. A child may receive a service in one state that is not available in another state. Moreover, services may even vary within a state from one local project to another. Therefore, the recruiter should inform the family that services can vary from one MEP to the next.

Referring Families and Youth to Appropriate Services. The recruiter, with the family’s consent, should feel free to refer a family to other suitable service providers. When the recruiter is able to accurately identify the family’s needs and provide complete information on the referral source, the family is more likely to get the services they need. In making a referral, the recruiter should provide the family with the following information:

- Name of organization
- Location and hours of operation
- Name of contact person and telephone number
- Eligibility criteria
- Services provided

To increase the likelihood that the family will actually receive services, the recruiter should follow-up by:

- Contacting the person to whom the migrant family was referred—after receiving the family’s consent to do so—and providing the following information: (1) the name of the family, (2) the service(s) needed, (3) the date the referral was made, and (4) contact information for the recruiter (or the family) if the family does not make contact.
- Following up with the family to see if they received the service(s) they needed.

Youth who qualify for the migrant program may be eligible for a variety of other services, including:

- ESL classes
- Adult Basic Education classes

- Referrals to health and other community services (e.g., legal, housing, clothing)
- “Reconnection” to high school programs
- Semi-independent study courses (e.g., the Portable Assisted Study Sequence (PASS))⁷
- Local volunteer or student group contacts

Do Not Set Recruitment Quotas. At times, the recruiter may use techniques that are similar to the strategies used in sales and promotion to find and recruit migrant children; however, the recruiter is not a salesperson. The recruiter should never feel compelled to meet specific recruitment targets or quotas. Instead, the recruiter should concentrate on finding all of the eligible children in the recruitment area to the best of his or her ability. Agricultural and fishing jobs may change over time due to factors such as development, farm consolidation, changing weather patterns etc., which can affect the number of migrant families and youth who move into a particular area to work. All the recruiter can do is find the eligible children who reside in the recruitment area. The recruiter should never feel pressured to make questionable eligibility determinations to increase the number of identified migrant children.

Do Not Give Families Recruitment Incentives. Never give families gifts like jackets or backpacks to entice them to enroll their children in the MEP. Giving gifts may encourage a family or youth to say what the recruiter wants to hear to get the gift. It can also cause hard feelings if one child receives a gift and another one does not. Once enrolled into the program, some programs may offer small “welcome bags” to eligible students as a means of reminding them about the MEP and preparing them for school, but this is not appropriate as a recruitment tool.

Conclusion

When conducting an eligibility interview, the recruiter should be prepared to do the following: introduce himself or herself, explain the reason for the visit, find common ground with the family to build rapport, screen the interviewee using the basic child eligibility factors to determine whether the child qualifies for the MEP, and use a supplemental interview form to obtain the supporting information needed to determine whether the child is eligible for the MEP and to fill out the national COE. The new recruiter may rely heavily on the more in-depth *Sample Interview Script* when conducting an interview, while a seasoned recruiter will learn how to draw out the information that is needed to determine eligibility using a more conversational approach or a more condensed supplemental interview form.

Interviewing skills develop and improve over time. With solid research, a good individual ID&R action plan, working knowledge of eligibility requirements, and practice, the recruiter will gain confidence and proficiency as an interviewer. The next chapter provides tools that will help the recruiter make accurate preliminary eligibility determinations.

⁷ Texas Education Agency, 2011-2012 *Texas Manual for the Identification and Recruitment of Migrant Children* (2012).

Recruiter Checklist

Chapter 6: Interviewing Migrant Families and Youth

Did you?

- Work with a supervisor to learn the *Sample Interview Script*?
- Prepare an introduction to the MEP and a way to connect with migrant families or youth?
- Memorize the basic child eligibility factors?
- Practice asking the numbered questions and probes in the *Sample Interview Script*?
- Develop a form or system for taking and saving notes?
- Review the steps to take before, during, and after visiting with a family or youth?
- Think about how to handle people who are uneasy or unwilling to be interviewed?
- Consider how to tell families that they are not eligible?
- Decide how to handle special situations, such as interviewing emancipated youth or someone who speaks another language?
- Prepare for your *first* interview?

Chapter 7. Determining Eligibility

The Importance of Accurate Determinations

It takes time and effort for the recruiter to complete the initial training, create an individual ID&R action plan, build a recruitment network, and learn the nuances of interviewing. However, all of this is critical preparation for one of the most important parts of the recruiter's job: making accurate preliminary eligibility determinations.

One of the primary responsibilities for a state in administering and operating the MEP is to identify those children who are eligible for the MEP so that they can receive the services they need. States are also required to provide to ED an annual count of the number of eligible migrant children who reside in the state. The state's ability to report this number accurately depends almost entirely on how adequately and accurately recruiters make eligibility determinations.

Eligible migrant children are deprived of services they need if the state serves ineligible children with MEP funds. Furthermore, the state may have to repay to ED MEP funds spent on ineligible children. Thus, accurate eligibility determinations are critical in order for a state to have an effective, compliant MEP. The cycle of responsible eligibility decisions begins with the MEP recruiter.

The Recruiter's Role

Although the recruiter's role in making preliminary eligibility determinations is critical, he or she should not feel overwhelmed by this responsibility. If the recruiter works hard to learn the eligibility requirements, applies that knowledge consistently, and seeks help from supervisors whenever he or she has an eligibility question, the recruiter will be able to identify and recruit migrant children who are truly eligible for the MEP.

If the recruiter has used *The Sample Interview Script* supplemental interview form to gather all of the information needed to make an eligibility determination, a simple review of the MEP eligibility criteria should usually lead the recruiter to conclude, "yes, this child is eligible" or "no, this child is not eligible." This process is meant to be straightforward. Questions occasionally arise when the information the recruiter receives on a particular factor or set of factors is unique or unclear. For example, a worker may have moved to perform an unusual agricultural activity that the state has not previously encountered.

Any time the recruiter has a question regarding whether a child or youth is eligible for the program, he or she should ask the supervisor for help. Every program has someone at either the local or state level, or both, who is responsible for resolving eligibility questions. It is important for every recruiter to know his/her point of contact and to feel comfortable contacting that person when questions arise. There will be more discussion on how to determine eligibility in difficult cases later in this chapter.

Primary Resources to Help Determine Eligibility

There are several documents that lay out the eligibility requirements for the MEP. The three sources listed below contain the basic eligibility definitions and criteria that recruiters are *required* to use to determine if a child or youth is eligible for the MEP. They include the relevant sections of the following:

1. Federal statute (see below).
2. Federal regulations (see below).
3. State requirements, if any.

In addition, there are a number of resources that have been developed to help recruiters determine a child or youth's eligibility for the MEP. These resources include the:

- *MEP Guidance*.
- *Basic Child Eligibility Factors Chart* (introduced later in this chapter).
- *Sample Interview Script* (see Appendix VIII).
- National Certificate of Eligibility (detailed information is provided in Chapter 8).
- The New Recruiter Self-Check (see Appendix IX).
- State manuals and/or recruitment tools.

The relationship between these documents and the interpretation of them by MEP personnel is key to properly determining child eligibility.

Who is a Migratory Child? A child is a “migratory child” and is eligible for MEP services if all of the following conditions are met:

1. The child is not older than 21 years of age; *and*
2. The child is entitled to a free public education (through grade 12) under state law or is below the age of compulsory school attendance; *and*
3. The child is a migratory agricultural worker or a migratory fisher *or* the child has a parent, spouse, or guardian who is a migratory agricultural worker or a migratory fisher; *and*
4. The child moved within the preceding 36 months in order to seek or obtain qualifying work, or to accompany or join the migratory agricultural worker or migratory fisher identified in paragraph three, above, in order to seek or obtain qualifying work; *and*
5. With regard to the move identified in paragraph 4, above, the child:
 - a. Has moved from one school district to another; *or*
 - b. In a state that is comprised of a single school district, has moved from one administrative area to another within such district; *or*

- c. Resides in a school district of more than 15,000 square miles and migrates a distance of 20 miles or more to a temporary residence to engage in or to accompany or join a parent, spouse, or guardian who engages in a fishing activity. (This provision currently applies only to Alaska.)

This definition appears in ED’s Guidance. It derives from the statutory and regulatory definitions of a “migratory child,” but restates the definitions in an easier to read format and it incorporates other applicable definitions from Title I⁸. The Guidance is intended to be the place where state and local MEP personnel can go to learn about the MEP statute and regulations in a format applicable to everyday situations. For this reason, the ID&R manual will refer frequently to the Guidance definition of “migratory child” instead of the statutory and regulatory definitions. Terms such as “migratory agricultural worker,” “migratory fisher,” “move or moved,” “in order to obtain,” and “qualifying work” are also defined in regulation (see below), but this manual also focuses on the discussion of these terms in the Guidance.

A brief description of the statute, regulations, Guidance, their relation to one another, and the eligibility definitions they include is provided below for reference.

The MEP Statute. The ESEA is the statute authorizing the MEP, as well as other educational programs at the federal level. It was first enacted by the U.S. Congress in 1965. The ESEA (also referred to as “the Act”) provides basic provisions for how SEAs and LOAs are to operate the MEP, including the definitions of the basic terms. It has been amended (or “reauthorized”) several times since 1965. The current amendment to the ESEA is known as the “No Child Left Behind” (NCLB) Act. Congress can change the ESEA only by enactment of another law or amendment. Section 1309(2) of the ESEA, as amended, defines a migratory child as follows:

MIGRATORY CHILD- The term “migratory child” means a child who is, or whose parent or spouse is, a migratory agricultural worker, including a migratory dairy worker, or a migratory fisher, and who, in the preceding 36 months, in order to seek or obtain, or accompany such parent or spouse, in order to seek or obtain, temporary or seasonal employment in agricultural or fishing work —

- (A) has moved from one school district to another;
- (B) in a state that is comprised of a single school district, has moved from one administrative area to another within such district; or
- (C) resides in a school district of more than 15,000 square miles, and migrates a distance of 20 miles or more to a temporary residence to engage in a fishing activity.

⁸ The first two conditions, are based on the term “eligible children” defined in section 1115(b)(1)(A) of the ESEA and the term “children” is defined in 34 CFR § 200.103(a). These Title I definitions apply to the MEP by virtue of section 1304(c)(2) of the ESEA.

The entire text of the MEP statute is available on ED's website at <http://www2.ed.gov/programs/mep/legislation.html#legislation>.

The MEP Regulations. Federal regulations are rules promulgated by Executive branch departments and agencies. Regulations interpret and fill in gaps in terms, phrases, practices, language contained in statute. Chapter 34 § 200.81 of the Code of Federal Regulations (C.F.R.) defines several terms that appear in the statutory definition of “migratory child”. Like the statute, regulations have the force of law and therefore must be followed. Section § 200.81 (a)-(k) states:

- a. *Agricultural work* means the production or initial processing of crops, dairy products, poultry, or livestock, as well as the cultivation or harvesting of trees. It consists of work performed for wages or personal subsistence.
- b. *Fishing work* means the catching or initial processing of fish or shellfish or the raising or harvesting of fish or shellfish at fish farms. It consists of work performed for wages or personal subsistence.
- c. *In order to obtain*, when used to describe why a worker moved, means that one of the purposes of the move is to seek or obtain qualifying work.
 - 1) If a worker states that a purpose of the move was to seek any type of employment, i.e., the worker moved with no specific intent to find work in a particular job, the worker is deemed to have moved with a purpose of obtaining qualifying work if the worker obtains qualifying work soon after the move.
 - 2) Notwithstanding the introductory text of this paragraph (c), a worker who did not obtain qualifying work soon after a move may be considered to have moved in order to obtain qualifying work only if the worker states that at least one purpose of the move was specifically to seek the qualifying work, and—
 - I. The worker is found to have a prior history of moves to obtain qualifying work; or
 - II. There is other credible evidence that the worker actively sought qualifying work soon after the move but, for reasons beyond the worker's control, the work was not available.
- d. *Migratory agricultural worker* means a person who, in the preceding 36 months, has moved, as defined in paragraph (g), from one school district to another, or from one administrative area to another within a state that is comprised of a single school district, in order to obtain temporary employment or seasonal employment in agricultural work, including dairy work.
- e. *Migratory child* means a child—
 - 1) Who is a migratory agricultural worker or a migratory fisher; or
 - 2) Who, in the preceding 36 months, in order to accompany or join a parent, spouse, or guardian who is a migratory agricultural worker or a migratory fisher—
 - I. Has moved from one school district to another;
 - II. In a state that is comprised of a single school district, has moved from one administrative area to another within such district; or
 - III. As the child of a migratory fisher, resides in a school district of more than 15,000 square miles, and migrates a distance of 20 miles or more to a temporary residence.

- f. *Migratory fisher* means a person who, in the preceding 36 months, has moved, as defined in paragraph (g), from one school district to another, or from one administrative area to another within a state that is comprised of a single school district, in order to obtain temporary employment or seasonal employment in fishing work. This definition also includes a person who, in the preceding 36 months, resided in a school district of more than 15,000 square miles and moved, as defined in paragraph (g), a distance of 20 miles or more to a temporary residence in order to obtain temporary employment or seasonal employment in fishing work.
- g. *Move or Moved* means a change from one residence to another residence that occurs due to economic necessity.
- h. *Personal subsistence* means that the worker and the worker's family, as a matter of economic necessity, consume, as a substantial portion of their food intake, the crops, dairy products, or livestock they produce or the fish they catch.
- i. *Qualifying work* means temporary employment or seasonal employment in agricultural work or fishing work.
- j. *Seasonal employment* means employment that occurs only during a certain period of the year because of the cycles of nature and that, by its nature, may not be continuous or carried on throughout the year.
- k. *Temporary employment* means employment that lasts for a limited period of time, usually a few months, but no longer than 12 months. It typically includes employment where the employer states that the worker was hired for a limited time frame; the worker states that the worker does not intend to remain in that employment indefinitely; or the SEA has determined on some other reasonable basis that the employment is temporary. The definition includes employment that is constant and available year-round only if, within 18 months after the effective date of this regulation and at least once every three years thereafter, the SEA documents that, given the nature of the work, of those workers whose children were previously determined to be eligible based on the state's prior determination of the temporary nature of such employment (or the children themselves if they are the workers), virtually no workers remained employed by the same employer more than 12 months.¹

The regulations that apply to the MEP are available on ED's website at <http://www.ed.gov/programs/mep/legislation.html#legislation>.

¹ 34 Code of Federal Regulations (CFR) §200.81

The MEP Guidance. ED's Guidance provides what ED considers to be the best and safest way to interpret and implement the MEP eligibility requirements. In addition to presenting MEP definitions and conditions in an easy-to-read question-and-answer format, the Guidance also provides examples of how to comply with the law. It is intended to be the place where state and local MEP personnel can read about the MEP statute and regulations in a format that is applicable to everyday situations. Every recruiter should study the Child Eligibility chapter of the MEP Guidance. Recruiters should also follow the policies provided in the Guidance unless they have clear written approval from state MEP officials stating otherwise.

The Guidance for the MEP is available on ED's website at <http://www2.ed.gov/programs/mep/legislation.html#guidance>.

State Requirements. States may provide their own interpretation of MEP eligibility requirements providing that the state interpretations are reasonable and comport with the federal statutes and regulations. The recruiter should find out if the state has any specific MEP requirements.

Basic Child Eligibility Factors Chart

To assist the recruiter in making eligibility decisions, OME has developed the *Basic Child Eligibility Factors Chart* (Figure 4). This tool is a graphic representation of the basic eligibility requirements.

Figure 4. Basic Child Eligibility Factors Chart

Basic Child Eligibility Factors	Yes	No
1. AGE: The child is younger than age 22.	√	
2. SCHOOL COMPLETION: The child is eligible for a free public education through grade 12 under state law. ¹	√	
3. MOVE: <ul style="list-style-type: none"> The child moved on his or her own as a migratory agricultural worker/fisher OR the child moved with or to join/precede a parent, spouse, or guardian who is a migratory agricultural worker/fisher, AND 	√	
<ul style="list-style-type: none"> The move was from one school district to another, AND 	√	
<ul style="list-style-type: none"> The move was a change from one residence to another residence, AND 	√	
<ul style="list-style-type: none"> The move was due to economic necessity, AND 	√	
<ul style="list-style-type: none"> The move occurred within the past 36 months. 	√	
4. PURPOSE OF MOVE: One <u>purpose</u> of the worker's move was to seek or obtain qualifying work : <ul style="list-style-type: none"> The worker moved to obtain qualifying work and obtained it, OR The worker moved to obtain any work and obtained qualifying work soon after the move, OR The worker moved for qualifying work specifically, but for reasons beyond his or her control, did not obtain the work, AND The worker has a prior history of moves to obtain qualifying work, OR There is other credible evidence that the worker actively sought qualifying work soon after the move. 	√	
5. QUALIFYING WORK: <ul style="list-style-type: none"> The employment is seasonal or temporary, AND 	√	
<ul style="list-style-type: none"> The work is agricultural or fishing. 	√	

¹ The recruiter should find out which older children are still entitled to a free public education in his or her state. If a question arises (e.g., the child has a secondary school degree issued by another country or has received a certificate of completion in lieu of a diploma), the recruiter should find out from state officials whether the child is entitled to continue to pursue a high school diploma in that state.

In order to be eligible for the MEP, a child must meet **all** of the basic eligibility criteria listed in Figure 4. The basic eligibility criteria are denoted in the chart above with a check mark to the right. If the answer to even one of these criteria is no, the child is not eligible for the MEP. If the recruiter is unclear about how to answer a statement, the recruiter must resolve the issue by (1) collecting any additional information that is needed to make a determination, and (2) following the state's procedure for resolving eligibility questions (e.g., consulting with a supervisor, asking the SEA to make a determination, etc.) **before** the child can be considered eligible for the program.

ED has provided *The Sample Interview Script* discussed in Chapter 6 (and provided in Appendix VIII), and the *Basic Child Eligibility Factors Chart* (Figure 4), to assist recruiters in making adequate and accurate eligibility determinations.

When the recruiter has: (1) learned the eligibility criteria contained in the MEP statute, regulations, and Guidance, (2) learned all applicable state laws, regulations and policies, and (3) practiced making eligibility determinations under supervision and/or with others in a team approach, the recruiter should be ready to make most preliminary eligibility determinations without help. As discussed previously, the recruiter is encouraged to talk with the supervisor any time he or she is uncertain whether a particular child or youth qualifies for the MEP.

Comprehensive Eligibility Training

This ID&R Manual is a resource developed to assist SEAs with ID&R systems implementation, as well as, provide a thorough understanding of MEP statute and regulations. While components of this manual discuss the necessary criteria for determining MEP eligibility, this manual is not intended to train recruiters on the many nuances of eligibility decisions; for that purpose, OME has developed an ID&R Curriculum. SEAs are responsible for providing all recruitment staff with comprehensive training. This can be accomplished by using OME's ID&R Curriculum or a similar SEA developed curriculum. OME's ID&R Curriculum can be found at: <http://RESULTS.ed.gov>.

Making Eligibility Decisions

In order to make adequate and accurate decisions regarding eligibility, the recruiter must gather as much relevant information as possible. Additional information or documentation the recruiter may wish to collect and/or review to support the determination includes:

- Notes from the eligibility interview (including the family's work history).
- School data (names and enrollment records from schools attended in the past).
- Employment data (employment records, pay stubs, job applications, names of past employers, etc.).
- Crop data (approximate dates of temporary or seasonal crop activities, qualifying local production, and processing activities).
- Migrant database records such as MSIX or an independent state database.
- Family documents (birth certificates, health immunization records).

- Names of other families with whom the family has worked or traveled.
- Information from the recruitment network that helped the recruiter to identify the worker or family (written and verbal referrals from community agencies, school personnel, employers, etc.).
- Recruiter observations (whether what the recruiter observes is consistent with the information the interviewee provides).
- Other relevant documentation.

The recruiter should remember that records from other states, including copies of COEs, may help inform eligibility determinations. However, each state must make its own eligibility decisions because each state is responsible for ensuring the eligibility of each child included in its annual child count.

The recruiter should use his or her analytical skills and all available resources (both material and people) to make a preliminary determination as to whether each child meets the definition of a migratory child. To make that decision the recruiter should review the information gathered at the interview, along with any other sources of information. The recruiter should also consider contradictory information from other sources or from observations that lead the recruiter to doubt or question the interviewee's responses, such as school records that do not match interview information (e.g., school records show the child in attendance every day in September, but the parent says they moved out of state for two weeks in September to pick apples. The school records might indicate that the child did not move with the parents).

It is critical that the recruiter remembers that children must meet *ALL* of the applicable eligibility criteria in the statute and regulations in order to be determined eligible for the MEP. If there is even one criterion that the child does not meet, the child does not qualify for the MEP.

Determining Eligibility in Difficult Cases

At times, the recruiter may face situations that are beyond his or her knowledge or level of authority. In this situation, it is imperative for the recruiter to take detailed notes during the interview, because it will allow the recruiter to effectively research any lingering questions at a later time. The recruiter should check to see if the question has been answered in the state's ID&R materials (e.g., the state ID&R Manual, state policy letters) or in the MEP's Guidance. If the recruiter cannot find the answer in any of the written materials, the recruiter will want to talk with knowledgeable peers in his or her state to see if any of them have encountered a similar situation, and if so, how it was resolved (eligibility policies may differ from state to state, so the recruiter should either ask other recruiters within his or her own state or confirm responses from other states with the state ID&R coordinator). Finally, the recruiter will also want to consult with a supervisor. To help the supervisor understand the scenario, the recruiter should clearly present all of the relevant facts. As a general rule, the individual who asks an eligibility question should provide as much applicable background information as possible, including information on each eligibility factor found on the *Basic Child Eligibility Factors Chart* (Figure 4). The recruiter should also tell the supervisor whether he or she thinks the child or youth is eligible and explain the rationale.

The recruiter’s supervisor, who will try to answer the eligibility question, should make sure he or she understands all of the relevant facts, asking for additional information when needed. Once the supervisor has a clear understanding of the issue, the supervisor should:

1. Check to see if the question is answered in the state ID&R materials (e.g., the state ID&R Manual, state policy letters) or in the MEP’s Guidance.
2. Determine if there is a precedent (by contacting the next person in the established process for resolving eligibility questions).

If there is a clear answer, the supervisor should provide that answer to the recruiter. If not, the supervisor should move the question through the state’s official process for resolving eligibility questions. The following graphic (Figure 5, below) shows how a question from a recruiter moves through the chain of command within the MEP and how the answer moves back to the recruiter. If the supervisor does not know the answer to a question, the question would be referred to the next person in line, generally the state ID&R coordinator, who will perform the same analysis that the local supervisor conducted.

Figure 5. Eligibility Question Chain of Command

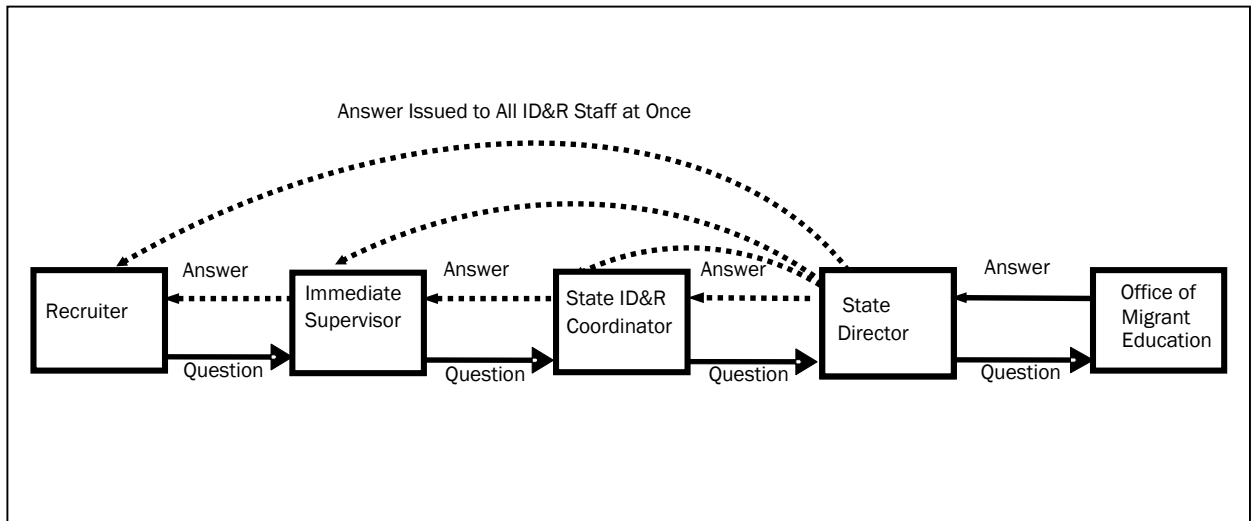

If the state ID&R Coordinator cannot answer the question, and the outcome will affect the eligibility of a significant number of children within the state, the State Director should send the question to the assigned OME program officer. A complete list of OME program officers can be found on ED’s website at <http://www.ed.gov/about/offices/list/oese/ome/aboutus.html#contact>.

Any question that is sent to OME should include the following information:

1. The question;
2. All of the facts that are relevant to the question;
3. The approximate number of children whose eligibility will be affected by the determination;
4. The state's analysis of the question;
5. Why the state believes the question does not have a clear answer; and
6. The response (i.e., ruling) that the state believes is appropriate based on its analysis.

In cases where the outcome will only affect the eligibility of a few children, the state is encouraged to make a decision on its own that is consistent with the statute and regulations. In cases where the eligibility of a large number of children will be affected, states are encouraged to refer their questions to OME. Regardless of who provides the answer, the recruiter should know there is support for answering difficult eligibility questions. The recruiter is encouraged to ask questions any time he or she is unsure whether a particular child qualifies for the MEP. As questions are answered, the state's process for resolving eligibility questions must allow for the response to be disseminated to all LOAs across the state. Not only is this required by regulation, it is a good professional development opportunity, and it is likely that if one recruiter encounters this question, others will as well.

The specific process for answering eligibility questions will vary somewhat from state to state depending on the size of the program and the recruitment model that the state uses. For example, the "immediate supervisor" and the "state ID&R coordinator" may be the same person in states that employ "statewide recruiters." Also, larger state and local programs may refer eligibility questions to experienced recruiters or to regional ID&R coordinators prior to referring them to the state ID&R coordinator. In some small states the state director may also serve as the state ID&R coordinator. In every case, all MEP personnel share the responsibility of ensuring that only eligible children are enrolled in the MEP.

The Recruiter's Instinct

Some experienced recruiters have said, "It only takes me about two minutes into the interview to tell if a child is eligible for the migrant program!" Can a recruiter truly develop an instinct or intuition for who is eligible and who is not? Over time, most workers develop a sense about their jobs, and the recruiter is no different. Thus, there are specific situations and places in which the new recruiter may begin to make educated guesses. For example, in many regions of receiving states, migrant families tend to live in particular housing units within the community (e.g., apartments in farming communities that offer short-term leases). Also, certain farms are more likely to employ migrant help. The recruiter can gather clues about eligibility from the way people answer questions, or from visual clues (e.g., a person who lives in a mansion or drives a brand new luxury car is not likely to be eligible for the MEP).

However, while instinct or educated guesses based on experience can help the recruiter focus on the children who are the most likely to be eligible for the MEP, there is no substitute for asking the necessary questions to determine the Basic Eligibility Factors. The new recruiter could use intuition as a guide on the most productive places to recruit, as well as when to probe more deeply, look for more evidence, find another source, or ask a question a second time. However, when making a preliminary eligibility determination, the decision must be based on facts and evidence, not simply on “gut feelings,” because that may not result in making an adequate and accurate determination.

Lessons Learned: Eligibility

When making preliminary eligibility determinations, there are several areas where problems can arise. Recruiters should watch out for these problem areas.

Warning Signs. At the time of an interview, there may be certain warning signs or red flags to alert the recruiter that a child or youth may not be eligible for the MEP. The recruiter should note that the presence of these red flags would not automatically disqualify a child from being eligible for the MEP, but instead indicate that the recruiter needs to ask additional questions, gather supporting documentation and, after concluding the interview, perhaps discuss the situation with others before making a preliminary eligibility decision. In these situations, the recruiter should not indicate to the family that they are eligible; rather, the recruiter should indicate that there is some information that needs to be checked before making a preliminary determination.

Listed below are a few examples of warning signs that should prompt the recruiter to dig deeper:

- First agricultural or fishing move: the family has not performed agricultural or fishing work before
- Moves to urban or non-traditional migrant areas: the family moves to an area where migrant work is not generally found
- Households where some members are employed in occupations that are not related to agriculture or fishing
- The worker has an occupation that is not related to agriculture or fishing for part of the year (especially if the worker goes back to this job regularly)
- A lifestyle where migration does not seem to be an important factor in the family’s life (non-traditional migrant housing, no school interruptions)
- Non-entry-level occupations, especially for the non-qualifying work: the worker or other family members have positions that are not entry-level or positions that require training or higher education
- New farm or industry with possibly new qualifying activities
- Moves of short duration or short distance: these types of moves might not be a change of residence due to economic necessity
- Travel associated with vacations, family events, holidays or other non-work reasons

- Moves in which the family arrives late in the season after agricultural or fishing jobs have been filled or early in the season before work is available

Quality Control. An SEA is required under MEP regulations to implement a system of quality control in order to promote adequate and accurate migrant child eligibility determinations. In the event that the recruiter misses warning signs or errs in some other way in making preliminary eligibility determinations, a quality control system must be in place for finding errors. The recruiter should know the basics of quality control and the federal and state requirements for ensuring the quality of child eligibility determinations. The recruiter should also be aware of his or her role in the state's quality control plan and assist in developing state and local plans. Understanding the benefit of having an effective quality control system and the consequences of having an ineffective system are essential to the recruiter's understanding of quality control.

34 C.F.R. § 200.89(d) of the MEP regulations require an SEA to establish and implement a quality control system with the following minimum components:

- Training to ensure that recruiters know the requirements for adequately and accurately determining and documenting child eligibility under the MEP.
- Training to ensure that all other staff involved in determining eligibility and in conducting quality control procedures know the requirements for adequately and accurately determining and documenting child eligibility under the MEP.
- Reviewing and evaluating an individual recruiter's ID&R practices on an annual basis.
- Supervising recruiters.
- Implementing a process to resolve eligibility questions raised by recruiters and supervisors, and to communicate responses to questions to all LOAs.
- Examining each COE to verify that the written documentation is sufficient and supports the recruiter's preliminary determination that the child is eligible for MEP services.
- Confirming eligibility determinations were made properly by conducting annual prospective re-interviewing.
- Documenting that the quality control system was implemented and maintaining a record of actions taken to improve the system where periodic reviews and evaluations indicate a need to do so.
- Implementing a process for implementing corrective action if the SEA finds COEs that do not sufficiently document a child's eligibility for the MEP, or in response to internal State audit findings and recommendations, or monitoring or audit findings of the Secretary.

An established plan for quality control is designed to help both the SEA and the recruiter learn from mistakes and improve child eligibility determinations. Quality control can also help identify falsification in determining eligibility.

Falsification. If the recruiter conducts thorough interviews and collects supporting documentation where needed, making preliminary eligibility determinations—including the process of resolving difficult cases—should be fairly straightforward. However, serious problems arise when the recruiter intentionally falsifies information on a COE. There are a number of reasons why the recruiter might falsify eligibility documentation, including the following:

- Even though the recruiter knows the child does not qualify for the MEP, the child or family really needs or deserves extra help.
- The recruiter does not believe that the government makes the best use of its funds; the recruiter believes it is better to spend this money helping children in need, regardless of their eligibility for the MEP.
- The recruiter gains status or importance in the migrant community by having the authority to decide which families are eligible and which are not.
- The recruiter feels that identifying more “eligible” migrant children makes his or her job more secure.

Although the recruiter may try to justify falsifying a COE, **knowingly falsifying information on a COE is a crime that is punishable by fines and/or imprisonment.** If a recruiter falsifies a COE to make an ineligible child or youth appear eligible, the consequences can be dire for the state, local MEP, and recruiter. States are liable for money spent on ineligible children, local programs can lose MEP funding, and MEP staff (including recruiters) can face prosecution. Falsifying information undermines both the fiscal and programmatic integrity of the MEP.

However, mistakes are not crimes, so the honest recruiter need not worry. It is the job of everyone in the MEP to find and correct mistakes as soon as possible. For this reason, data entry specialists, supervisors, state ID&R staff, and/or independent auditors may check COEs regularly. States are encouraged to implement a rigorous quality control system. Annually, states must conduct prospective re-interviewing. This process requires individuals to re-interview or re-verify the eligibility of a random sample of child eligibility determinations. Usually, this process is carried out by someone who is employed by the MEP, but this person was not associated with the original eligibility determination. Every third year, states must have an independent re-interviewer (someone external to the local and state MEP) carry out this process. This ensures the quality of the recruitment system and of every recruiter’s work. This system helps the honest recruiter get better by finding, correcting, and learning from mistakes. Implementing quality control plans helps to ensure that the statewide recruitment system is consistently making valid eligibility determinations. (For more on falsification, see Chapter 5).

Report Fraud or Misconduct. The recruiter should follow his or her state’s policies to report fraud or misconduct. If the recruiter feels pressured by a supervisor or colleague to enroll a child who does not appear to be eligible for the MEP or to increase the program’s numbers of identified children, the recruiter should:

- Make it clear that the recruiter is not comfortable with what is being asked.

- Write down what happened with as much detail as possible (if others witnessed what happened, have them write down what they observed as well).
- Report what happened to the appropriate person (if the supervisor is the person who is applying the pressure, the recruiter should report the problem to someone at a higher level within the MEP).

The recruiter should not do things that he or she believes are wrong, and should follow up on any concerns until they have been properly addressed. Furthermore, if the recruiter suspects that another recruiter is enrolling children in the MEP who are *not* eligible, the recruiter is obligated to report that as well. It is everyone's job to preserve the integrity of the MEP and to maintain public confidence in the program's efforts to find and serve eligible migrant children. If the state MEP does not address the recruiter's concern, the recruiter should report the problem to the program officer at OME. Current contact information for the OME is available on ED's website at <http://www.ed.gov/about/offices/list/oese/ome/aboutus.html#contact>.

Anyone suspecting fraud, waste, or abuse involving ED funds or programs is advised to call or write to the Office of the Inspector General's (OIG) Hotline. The OIG keeps these complaints confidential; it will not release the recruiter's name, address, or any other identifying information. The OIG can be contacted using any of the following methods:

- Call the OIG Hotline's toll free number 1-800-MIS-USED. The Hotline's operating hours are from 9:00 a.m. until 4:00 p.m. Eastern Time, Monday through Friday, except for holidays.
- Send an email message to oig.hotline@ed.gov.
- Complete and submit an electronic complaint form, which is available on ED's website at: <http://www2.ed.gov/about/offices/list/oig/hotline.html>.
- To ensure complete anonymity, download a hard copy of the complaint form, complete, and mail to: Inspector General's Hotline; Office of Inspector General; U.S. Department of Education; 400 Maryland Avenue, SW; Washington, D.C. 20202-1510.

Fraud is a crime; intentional falsification should be taken seriously by everyone and should be reported immediately.

Conclusion

One of the most important parts of the recruitment system is making correct eligibility determinations. By gathering all of the information needed to make a determination and carefully applying the rules of eligibility, the recruiter should have everything needed to make an adequate and accurate preliminary determination. Every MEP success story begins with a recruiter who made an adequate and accurate preliminary eligibility determination. Every migrant child who improves in reading, every migrant mother who learns how to better prepare her child for kindergarten, and every migrant teenager who graduates from high school began with a recruiter who found and correctly identified him or her.

The next chapter will explain how to complete a COE.

Recruiter Checklist

Chapter 7: Determining Eligibility

Did you?

- Consider how to use the *Basic Child Eligibility Factors Chart*?
- Talk about how to resolve difficult eligibility cases with your supervisor?
- Discuss your role in quality control?
- Think about the consequences of bending the rules in making eligibility determinations?
- Prepare to make your *first* preliminary eligibility determination?
- Think about what you would do if you suspected fraud or falsification of COEs?

Chapter 8. Completing the Certificate of Eligibility

Documenting Eligibility

The recruiter's job is not complete until the eligibility determination has been documented.

The recruiter should now know how to find migrant workers and families and understand the rules and regulations regarding eligibility. In particular, the recruiter should know how to ask basic eligibility questions and conduct interviews, and be able to make preliminary eligibility determinations. The next step in the process is to document each child's eligibility on the COE form.

States are required to use the COE form issued by ED. The form and accompanying instructions establish the minimum requirements the SEA must meet to document its eligibility determinations under the MEP. The national COE is comprised of three parts:

1. **Required data elements**, which states can organize according to state preference and need.
2. **Required data sections**, which states can place according to state preference and need, but must be maintained in whole and unaltered.
3. **State required/requested information**, where space is available, for states to use if they choose to collect other data¹.

The instructions for completing a COE in this chapter are based on the national COE form. This chapter outlines all required data elements in addition to offering instruction for the most common state required information. The chapter notes when data elements are not federally required.

The Purpose of a COE

You should be able to read a COE like a storybook that tells the story of a migrant family.

The SEA is ultimately responsible for documenting every migrant child's eligibility for the MEP on the national COE form. The COE serves as the official record of why the recruiter and state believe the child is eligible for the MEP. Because the COE establishes the basis for a particular child's eligibility, it is crucial that the information on the COE be adequate, accurate and reliable. As such, it is important that the COE be properly reviewed, filed, secured, and maintained so it is available for review at any time.

The recruiter obtains the information needed to complete the COE by conducting a personal interview with a migrant worker or credible family member and collects supporting documentation, where needed. As stated in previous chapters, states may require recruiters to complete other forms to provide additional information on why the child is eligible or to gather additional information

¹ ED, National Certificate of Eligibility, COE Instructions

needed by the state (e.g., parental permission for the child to participate on field trips, a supplemental interview form, etc.). The recruiter should only enter data on a COE if the recruiter finds the source to be credible and believable since the COE serves as the primary record of eligibility when an auditor or reviewer checks the child's eligibility. States often use the information from the COE to determine the number of migrant children who live in the state each year and to compile demographic information about these migrant children. States are required to complete a COE before the MEP provides services to a child. For these reasons, the COE is the most important document generated by the MEP and it is vital that it is completed adequately and accurately.

Required Data Elements (continued on following page).

Family Data

Male Parent/Guardian Last Name
 Male Parent/Guardian First Name
 Female Parent/Guardian Last Name
 Female Parent/Guardian First Name
 Current Address
 City
 State
 Zip
 Telephone

Child Data

Residency Date
 Last name 1
 Last name 2
 Suffix
 First name
 Middle name
 Sex
 Birth Date
 Multiple Birth Flag (or MB)
 Birth Date Verification Code (or Code)

Required Data Sections

Qualifying Move & Work Section

1. The child(ren) listed on this form moved from a residence in _____ School district / _____ City / _____ State / _____ Country to a residence in _____ School district / _____ City / _____ State.
2. The child(ren) moved (complete both a. and b.):
 - a. on own as worker, OR with the worker, OR to join or precede the worker.
 - b. The worker, _____ First Name and Last Name of Worker _____, is the child or the child's
 - parent spouse guardian.
 - i. (Complete if "to join or precede" is checked in 2a.) The worker moved on _____ MM/DD/YY _____.
 - The child(ren) moved on _____ MM/DD/YY _____. (provide comment)
3. The Qualifying Arrival Date was _____ MM/DD/YY _____.
4. The worker moved due to economic necessity in order to obtain:
 - a. qualifying work, and obtained qualifying work, OR
 - b. any work, and obtained qualifying work soon after the move, OR
 - c. qualifying work specifically, but did not obtain the work. If the worker did not obtain the qualifying work:
 - i. The worker has a prior history of moves to obtain qualifying work (provide comment), OR
 - ii. There is other credible evidence that the worker actively sought qualifying work soon after the move (provide comment).
5. The qualifying work,* _____ describe agricultural or fishing work _____ was (make a selection in both a. and b.):
 - a. seasonal OR temporary employment
 - b. agricultural OR fishing work

*If applicable, check:
 personal subsistence (provide comment)
6. (Complete if "temporary" is checked in #5a) The work was determined to be temporary employment based on:
 - a. worker's statement (provide comment), OR
 - b. employer's statement (provide comment), OR
 - c. State documentation for _____ Employer _____.

Comment Section (Must include 2bi, 4c, 5, 6a and 6b of the Qualifying Move & Work Section, if applicable)

Parent/Guardian/Spouse/Worker Signature Section

I understand the purpose of this form is to help the state determine if the child(ren)/youth listed on this form is/are eligible for the Title I, Part C Migrant Education Program. To the best of my knowledge, all of the information I provided to the interviewer is true. [This section must include fields labeled "Signature," "Relationship to the child(ren)," and "Date".]

Eligibility Certification Section

I certify that based on the information provided to me, which in all relevant aspects is reflected above, I am satisfied that these children are migratory children as defined in 20 U.S.C. 6399(2) and implementing regulations, and thus eligible as such for MEP services. I hereby certify that, to the best of my knowledge, the information is true, reliable, and valid and I understand that any false statement provided herein that I have made is subject to fine or imprisonment pursuant to 18 U.S.C. 1001. [The section must include fields labeled "Signature of Interviewer," "Signature of Designated SEA Reviewer," and "Date" for each signature.]

State Name: _____

National Certificate of Eligibility Template

Migrant Education Program

I. FAMILY DATA

Male Parent/Guardian:	Last Name	First Name	Female Parent/Guardian:	Last Name	First Name	
Current Address:			City	State	Zip	Telephone

II. CHILD DATA

Last Name 1	Last Name 2	Suffix	First Name	Middle Name	Sex	Birth Date	MB	Code	Residency Date

III. QUALIFYING MOVE & WORK

1. The child(ren) listed on this form moved from a residence in _____ /
City / State / Country to a residence in _____ /
City / State
2. The child(ren) moved (complete both a. and b.):
 - a. on own as worker, OR with the worker, OR to join or precede the worker.
 - b. The worker, _____, is the child or the child's parent spouse guardian.
 - i. (Complete if "to join or precede" is checked in 2a.) The worker moved on ____MM/DD/YY____. The child(ren) moved on ____MM/DD/YY____. (provide comment)
3. The Qualifying Arrival Date was ____MM/DD/YY____.
4. The worker moved due to economic necessity in order to obtain:
 - a. qualifying work, and obtained qualifying work, OR
 - b. any work, and obtained qualifying work soon after the move, OR
 - c. qualifying work specifically, but did not obtain the work. If the worker did not obtain the qualifying work:
 - i. The worker has a prior history of moves to obtain qualifying work (provide comment), OR
 - ii. There is other credible evidence that the worker actively sought qualifying work soon after the move (provide comment).
5. The qualifying work,* _____, was (make a selection in both a. and b.):
 - a. seasonal OR temporary employment
 - b. agricultural OR fishing work
6. (Complete if "temporary" is checked in #5a) The work was determined to be temporary employment based on:

<ol style="list-style-type: none"> a. <input type="checkbox"/> worker's statement (provide comment), OR b. <input type="checkbox"/> employer's statement (provide comment), OR c. <input type="checkbox"/> State documentation for _____. 	<p style="text-align: center;">*If applicable, check:</p> <input type="checkbox"/> personal subsistence (provide comment)
--	---

IV. COMMENTS (Must include 2bi, 4c, 5, 6a and 6b of the Qualifying Move & Work Section, if applicable.)

V. PARENT/GUARDIAN/SPOUSE/WORKER SIGNATURE

I understand the purpose of this form is to help the State determine if the child(ren)/youth listed on this form is/are eligible for the Title I, Part C, Migrant Education Program. To the best of my knowledge, all of the information I provided to the interviewer is true.

Signature	Relationship to the child(ren)	Date

VI. ELIGIBILITY DATA CERTIFICATION

I certify that based on the information provided to me, which in all relevant aspects is reflected above, I am satisfied that these children are migratory children as defined in 20 U.S.C. 6399(2) and implementing regulations, and thus eligible as such for MEP services. I hereby certify that, to the best of my knowledge, the information is true, reliable, and valid and I understand that any false statement provided herein that I have made is subject to fine or imprisonment pursuant to 18 U.S.C. 1001.

Signature of Interviewer	Date
Signature of Designated SEA Reviewer	Date

Instructions for the National COE

The national COE template and corresponding instructions are available on ED's website at <http://www.ed.gov/programs/mep/legislation.html#legislation>. For convenience, the instructions are provided, in full, in this chapter of the ID&R manual.

General Instructions

- A COE must be completed every time a child makes a new qualifying move.
- All attempts should be made to complete all data elements and sections of the COE. In cases where a response may not be required or does not apply, flexibility has been built into the instructions. In these cases, the recruiter must write a dash (-) or "N/A" in the appropriate blank. All other information must be provided.
- With the exception of the "Qualifying Move and Work Section," if the instructions ask for additional information in the Comments section and the state has required this information as a state data element, the recruiter does not need to provide the information again in the Comments section. For example, the instructions prompt the recruiter to record the first and last names of the child's legal parents in the Comments section if different from the current parents. However, if the state includes data elements for legal parent information, the recruiter would not have to repeat this information in the Comments section.
- If the recruiter completes a COE for a family, the recruiter must fill out a separate COE for any child who has a different qualifying arrival date (QAD) or for any child who has different eligibility criteria than the rest of the children in the family, such as an out of school youth (OSY) who may have moved on his or her own. In general, the QAD is the date that both the child and worker completed the move for the worker to find qualifying work. There are special cases that are described in the instructions for the section titled "Qualifying Move and Work Section."
- The recruiter must not include any child who:
 1. Was born after the qualifying move.
 2. Is not eligible to receive a free public school education [e.g., has graduated from a high school or obtained a General Educational Development (GED) certificate].
 3. Did not make the qualifying move described on the COE.
- If more than one COE is necessary, the recruiter must complete all sections on each form.

Completing the Data Elements of the COE

Family Data. In this section of the COE, the recruiter will record the name and address of the child's male and/or female parent or parents. The recruiter may have to pay special attention to ensure that the family's last name is accurate. A mother and father may have different last names or hyphenated names, or the use of last names may vary by culture or ethnic group. It is important that the recruiter become familiar with the naming customs of the various groups that the local MEP serves.

- *Male Parent/Guardian [Last Name(s), First Name].* Record the name of the male (if any) currently responsible for the child(ren). Record this individual's legal last name (or names) and legal first name. If the male parent has two last names or a hyphenated last name, record the male parent's last name(s) as it legally exists. The term "parent" on this form and in other sections of these instructions includes a legal guardian or other person who is standing in the place of the parent or *in loco parentis* (such as a grandparent, spouse, or stepparent with whom the child lives who is responsible for the welfare of the child). If the child has more than one male parent or if the child's legal parent is different from the current parent, provide the name of the child's legal male parent in the Comments section. If there is no parent information disclosed, write a dash (-) or "N/A." If the "child" is the worker and a male, write the child's name for this data element.
- *Female Parent/Guardian [Last Name(s), First Name].* Record the name of the female (if any) currently responsible for the child(ren). Record this individual's legal last name (or names) and legal first name. If the female parent has two last names or a hyphenated last name, record the female parent's last name(s) as it legally exists. The term "parent" on this form and in other sections of these instructions includes a legal guardian or other person who is standing in the place of the parent or *in loco parentis* (such as a grandparent, spouse, or stepparent with whom the child lives who is responsible for the welfare of the child). If the child has more than one female parent or if the child's legal parent is different from the current parent, provide the name of the child's legal female parent in the Comments section. If there is no parent information disclosed, write a dash (-) or "N/A." If the "child" is the worker and a female, write the child's name for this data element.
- *Current Address.* Record the physical address, including the complete name of the street or road where the child(ren) currently resides. In cases where a formal physical address is not available, include as much other identifying information as possible (e.g., trailer number, rural route, migrant camp, landmark). If the physical address is different from the mailing address, provide the mailing address in the Comments section of the COE.
- *City.* Record the name of the city or town where the child(ren) currently resides.
- *State.* Record the postal abbreviation used by the U.S. Postal Service for the state where the child(ren) currently resides.

- *Zip.* Record the five or nine-digit zip code where the child(ren) currently resides. The U.S. Postal Service has an online zip code directory service at <http://zip4.usps.com/zip4/welcome.jsp>.
- *Telephone.* Record the telephone number, including area code, of the family. If no telephone number is available, write a dash (-) or “N/A.”

Child Data. Child/school data includes the name, sex, birth date, etc. of each child. A recruiter should include all children with the same family and eligibility data on the same COE. Any child who has different (1) current family [see “Family Data” above for additional definition] or (2) eligibility data—including a different QAD—must be documented on a separate COE.

- *Residency Date.* If the “Residency Date” is different from the QAD, record the date (MM/DD/YY) that the child(ren) entered the present school district. Use the two-digit number that refers to the month and day, and the last two digits of the year. For example, May 20, 2008, would be written as 05/20/08. If the child(ren) qualified for the MEP on a move prior to the move to the present school district, the residency date will be later than the QAD. If the child(ren) moved prior to the worker’s move, the residency date would precede the QAD. If the “Residency Date” is the same as the QAD, write a dash (-) or “N/A.”
- *Last name 1.* Record the legal last name of each eligible child in the family. If the child has a multiple or hyphenated last name (e.g., Ramírez-García), record the first part of the name (i.e., Ramírez).
- *Last name 2.* If the child has a multiple or hyphenated last name (e.g., Ramírez-García), record the second part of the name (i.e., García). If the child does not have a multiple or hyphenated name, write a dash (-) or “N/A.”
- *Suffix.* Where applicable, record the child’s generation in the family (e.g., Jr., Sr., III, 3rd). Otherwise, write a dash (-) or “N/A.”
- *First name.* Record the legal first name of each eligible child in the family. This is the name given to the child at birth, baptism, or during another naming ceremony, or through a legal name change. Do not record nicknames or shortened names (e.g., Ale or Alex for Alejandra).
- *Middle name.* Record the legal middle name of each eligible child in the family. This is the secondary name given to the child at birth, baptism, or during another naming ceremony, or through a legal name change. Do not record nicknames or shortened names (e.g., Ale or Alex for Alejandra). If the child does not have a middle name, write a dash (-) or “N/A.”
- *Sex.* Record the child’s sex: “M” for male or “F” for female.
- *Birth Date.* Record the month, day and year the child was born. Use the two-digit number that refers to the month and day, and the last two digits of the year. For example, September 20, 2003, would be written as 09/20/03.

- *Multiple Birth Flag (MB)*. Record “Y” for “yes” if the child is a twin, triplet, etc. Write a dash (-) or “N/A” for not applicable (i.e., the child is not a twin, triplet, etc.).
- *Birth Date Verification Code (Code)*. Record the last two numbers that correspond to the evidence used to confirm each child’s birth date (see the codes and corresponding evidence listed below).

A birth certificate is the best evidence of the child’s birth date, if available. If a birth certificate is not available, the interviewer may use another document to confirm the child’s birth date, including any of those listed below.

1003 – baptismal or church certificate;	1010 – previously verified school records;
1004 – birth certificate;	1011 – state-issued ID;
1005 – entry in family Bible;	1012 – driver’s license;
1006 – hospital certificate;	1013 – immigration document;
1007 – parent’s affidavit;	2382 – life insurance policy; or
1008 – passport;	9999 – other.
1009 – physician’s certificate;	

If written evidence is not available, the interviewer may rely on a parent’s or emancipated youth’s verbal statement. In such cases, the interviewer should record “07” – the number that corresponds to “parent’s affidavit.”

Qualifying Move & Work Section. While all of the information on the COE should be completed adequately and accurately, the eligibility data elements are absolutely critical, as they document why the state believes the child(ren) are eligible to receive MEP services. Auditors often focus on this section because the child(ren)’s eligibility rests on the adequacy and accuracy of the information provided here. Most of the information that is recorded will come from the interview discussed in Chapter 6. However, in some cases, the worker may not know whether the work he or she moved to obtain is temporary or seasonal (information required for the COE). However, by understanding and evaluating the answers given, the recruiter should be able to provide adequate and accurate information on the COE and, more importantly, make reliable preliminary eligibility determinations.

In this section, recruiters will record the qualifying move and qualifying work information which the state believes documents the child’s eligibility for the program. Note that exceptions apply for moves within states comprised of a single school district and school districts of more than 15,000 square miles.

Required Data Section¹

1. *The child(ren) listed on this form moved from a residence in _____ (School District/City/State/Country) to a residence in _____ (School District/City/State).*
- *from a residence in _____ (School District/City/State/Country).* Enter the full legal or commonly used name of the local educational agency (i.e., school district or local operating agency) from where the child(ren) listed moved. This location is the last place of residency before the child(ren) and the parent, spouse, or guardian moved due to economic necessity in order to obtain qualifying work. If the most recent move was from a country outside of the U.S., enter the country instead of the state. Note that the child(ren) might have made subsequent non-qualifying moves.
 - *to a residence in _____ (School District/City/State).* This location is the place of residency to which the child(ren) and the parent, spouse, or guardian moved due to economic necessity in order to obtain qualifying work. A qualifying move can never be made to a country outside of the United States. As mentioned previously, the child(ren) might have made subsequent non-qualifying moves.

The following are several “qualifying move” scenarios. Identify which scenario applies to the specific eligibility situation and record the necessary information.

- If the child(ren) moved from a residence in one school district to a residence in another school district within the same U.S. city -
 - *from a residence in _____ (School District/City/State/Country) -* Record the full legal or commonly used name of the school district where the child(ren) listed resided immediately prior to the qualifying move. Also record the name of the city from which the child(ren) listed moved.
 - *to a residence in _____ (School District/City/State) -* Record the full legal or commonly used name of the school district where the child(ren) listed resided immediately following the qualifying move. Also record the name of the city from which the child(ren) listed moved.
- If the child(ren) moved from a residence in one school district to a residence in another school district within the same U.S. state (and these school districts are not within the same U.S. city) -
 - *from a residence in _____ (School District/City/State/Country) -* Record the name of the city where the child(ren) listed resided immediately prior to the qualifying move.
 - *to a residence in _____ (School District/City/State) -* Record the name of the city where the child(ren) listed resided immediately following the qualifying move.

¹U.S. Department of Education, National Certificate of Eligibility, COE Instructions

- If the child(ren) moved from a residence in one U.S. state to a residence in another U.S. state -
 - *from a residence in _____ (School District/City/State/Country) -* Record the name of the city and state where the child(ren) listed resided immediately prior to the qualifying move.
 - *to a residence in _____ (School District/City/State) -* Record the name of the city and state where the child(ren) listed resided immediately following the qualifying move.
- If the child(ren) moved from a residence in a country other than the U.S. to a residence in the U.S. -
 - *from a residence in _____ (School District/City/State/Country) -* Record the name of the state (within the other country) if available and the name of the country where the child(ren) listed resided immediately prior to the qualifying move.
 - *to a residence in _____ (School District/City/State) -* Record the name of the city and state in the U.S. where the child(ren) listed resided immediately following the qualifying move.
- **Exception.** If the child(ren) migrated a distance of 20 miles or more to a temporary residence in a school district of more than 15,000 square miles (NOTE: this exception only applies to the children of migratory fishers or children who are migratory fishers) -
 - *from a residence in _____ (School District/City/State/Country) -* Record the name of the city where the child(ren) listed resided immediately prior to the qualifying move. Also record the name of the school district within which this city is located. (NOTE: school district name is requested in order to identify this move as one that meets the 20 miles criterion.)
 - *to a residence in _____ (School District/City/State) -* Record the name of the city where the child(ren) listed resided immediately following the qualifying move. Also record the name of the school district within which this city is located. (NOTE: school district name is requested in order to identify this move as one that meets the 20 miles criterion.)
- **Exception.** If the child(ren) moved from a residence in one administrative area to a residence in another administrative area within a U.S. state that is comprised of a single school district -
 - *from a residence in _____ (School District/City/State/Country) -* Record the full legal or commonly used name of the administrative area where the child(ren) listed resided immediately prior to the qualifying move. Also record the name of the city from which the child(ren) listed moved.
 - *to a residence in _____ (School District/City/State) -* Record the full legal or commonly used name of the administrative area where the child(ren) listed

resided immediately following the qualifying move. Also record the name of the city from which the child(ren) listed moved.

- Provide as much of this information in these blanks as available. At a minimum (with the exception of states comprised of single school districts or school districts of more than 15,000 square miles), the state must be able to document that the child moved across school district lines and changed residences in the process. In the case of states comprised of a single school district, the state must be able to document that the child moved from one administrative area to another and changed residences in the process. In the case of school districts of more than 15,000 square miles, the state must be able to document that the child migrated a distance of 20 miles or more and changed residences in the process.
- If the child and parent moved from different previous residences, record the child’s prior residence in response to #1 and record the parent’s residence in the Comments section. In order for the child to be eligible, both the child and the parent must have moved across school district lines and changed residences in the process.
- For more information on documenting the move from one school district to another, see the chart provided below.

Type of move	The child’s residence immediately prior to the qualifying move	The child’s residence immediately following the qualifying move
The child(ren) moved...	The child(ren) moved from a residence in _____ (School District/City/State/Country)	The child(ren) moved to a residence in _____ (School District/City/State)
...from one school district to another within the same U.S. city	School District, City	School District, City
...from one school district to another within the same U.S. state	City	City
...from one U.S. state to another U.S. state	City, State	City, State
...from a country other than the U.S. to the U.S.	State, Country	City, State
...20 miles or more within a school district of more than 15,000 square miles (exception)	School District, City	School District, City
...From one administrative area to another within a U.S. state comprised of a single school district (exception)	Administrative Area, City	Administrative Area, City

2. *The child(ren) moved (complete both a. and b.):*

- a. on own as a worker, OR with the worker, OR to join or precede the worker.
[Mark only one box]

- Mark the box “on own as a worker” if the child himself or herself moved in order to obtain qualifying work. Only complete the worker’s name in 2b.
- Mark the box “with the worker” if the child(ren) moved with a parent, spouse, or guardian in order for the worker to obtain qualifying work.
- Mark the box “to join or precede the worker” if the child(ren) moved either before or after the date the parent, spouse, or guardian moved in order to obtain qualifying work. If this box is marked, also complete “i” under 2b.

- b. The worker, _____ (First and Last Name of Worker), (Continued below)

- Record the first and last name of the individual who sought or obtained the qualifying work (i.e., parent, spouse, guardian, or child – if on own as a worker).

(Continued from above) ...is the child or the child’s parent spouse guardian.
[Mark only one box]

- Mark the box that indicates the child’s relationship to the worker (i.e., parent, spouse or guardian). Do not select one of these boxes if “on own as a worker” is checked in 2a.
- *(Complete if “to join or precede” is checked in 2a.) The worker moved on _____ (MM/DD/YY). The child(ren) moved on _____ (MM/DD/YY). (provide comment)*
 - Record the date the worker moved in order to obtain qualifying work. Also record the date the child(ren) moved in order for the parent, spouse, or guardian to obtain qualifying work. Also record the reason for the different moves in the Comment section.

3. *The Qualifying Arrival Date (QAD) was _____ (MM/DD/YY). Record the QAD, using the two-digit numbers that refer to the month and day, and the last two digits of the year. For example, May 20, 2010, would be written as 05/20/10.*

- In general, the QAD is the date that both the child and worker completed the move. The child must have moved on his or her own, or with or to join a parent, guardian, or spouse to enable the worker (i.e., child, parent, guardian, or spouse) to obtain qualifying work. As referenced in 2a, the child and worker will not always move together, in which case the QAD would be the date the child joins the worker who has already moved, or the date when the worker joins the child who has already moved. (For more on “to join” moves, see *Guidance*, Chapter II, Question E2, Page 23.) The QAD is the date that the child’s eligibility for the MEP begins. The QAD is not affected by subsequent non-qualifying moves. For more information on determining the QAD, see the chart below.

Type of Qualifying Move The child . . .	Qualifying Arrival Date (QAD)–Eligibility Begins The QAD is . . .
. . .moved <u>with</u> the worker.	. . .the date the <u>child and worker both arrive</u> in the district where the worker will look for qualifying work.
. . .moved <u>before</u> the worker moved.	. . .the date the <u>worker arrives</u> in the district to look for qualifying work.
. . .moved to join the worker <u>after</u> the worker moves.	. . .the date the <u>child arrives</u> to join the worker.

4. *The worker moved due to economic necessity in order to obtain: (Mark only one of the following boxes: either a, b, or c.)*

- a. qualifying work, and obtained qualifying work, OR
 - Mark this box if the child, parent, spouse, or guardian moved due to economic necessity in order to obtain temporary or seasonal employment in agricultural or fishing work, and obtained that work.

- b. any work, and obtained qualifying work soon after the move, OR
 - Mark this box if the child, parent, spouse or guardian, moved due to economic necessity in order to obtain any work, and soon after the move obtained temporary or seasonal employment in agricultural or fishing work.

- c. qualifying work specifically, but did not obtain the work. If the worker did not obtain the qualifying work: (NOTE: Also complete box “i,” box “ii,” or both.)
 - Mark this box if the child, parent, spouse, or guardian moved due to economic necessity to obtain temporary or seasonal employment in agricultural or fishing work, but did not obtain that work. If this box is marked, also mark box i, box ii, or both.
 - i. The worker has a prior history of moves to obtain qualifying work (provide comment), OR
 - Mark this box to indicate that the worker has a prior history of moving to obtain temporary or seasonal employment in agricultural or fishing work. Explain this history in the Comments section. For example, the recruiter could write, “qualifying worker moved from Brownsville, Texas, to Decatur, Michigan, to plant tomatoes in May of 2012.” The recruiter could also check the MSIX database, or other local database, to see if it contains a history of prior moves to obtain qualifying work and attach the print-out to the COE.

ii. here is other credible evidence that the worker actively sought qualifying work soon after the move (provide comment).

- Mark this box to indicate that there is other credible evidence that demonstrates that the worker actively sought qualifying agricultural or fishing work soon after the move, but the work was not available for reasons beyond the worker's control. For example, a local farmer or grower confirmed that the worker applied for qualifying work but none was available; newspaper clippings document that work was not available because of a recent drought, flood, hail storm, or other disaster in the area. Explain this evidence in the Comment section and attach supporting documentation where available.

5. *The qualifying work**, _____ (describe agricultural or fishing work),
(Continued below)

- When describing the specific agricultural or fishing work, the recruiter should use a verb (e.g., picking) and a noun (e.g., strawberries). In other words, the recruiter should describe the worker's action (e.g., picking) and the crop, livestock, or seafood (e.g., strawberries). For example: picking strawberries, thinning sugar beets, pruning grapes, de-tasseling corn, catching chickens, planting oysters, walking (weeding) soybeans, and harvesting crabs.

(Continued from above)...was (make a selection in both a. and b.):

a. seasonal OR temporary employment, (Continued below)

- Mark the box for "seasonal employment" if the employment occurs only during a certain period of the year because of the cycles of nature and that, by its nature, may not be continuous or carried on throughout the year. Examples include planting, cultivating, pruning, harvesting, and related food processing in agriculture. Also, planting and harvesting clams and oysters, fishing during seasonal runs of fish, and related food processing in commercial fishing (§ 200.81(j)).
- Mark the box for "temporary employment" if the employment lasts for a limited period of time, usually a few months, but not longer than 12 months. It typically includes employment where the worker states that the worker does not intend to remain in that employment indefinitely, the employer states that the worker was hired for a limited time frame, or the SEA has determined on some other reasonable basis that the employment is temporary. (§ 200.81(k)).

(NOTE: The definition of temporary employment includes employment that is constant and available year-round only if, consistent with the requirements of § 200.81(k) of the regulations, the SEA documents that, given the nature of the work, of those workers whose children were previously determined to be eligible based on the state's prior determination of the temporary nature of such employment (or the children themselves if they are the workers), virtually no workers remained employed by the same employer more than 12 months.)

b. (Continued from above)... agricultural OR fishing work.

- Mark the box for “agricultural work” if the work involves the production or initial processing of crops, dairy products, poultry, or livestock, as well as the cultivation or harvesting of trees (§ 200.81(a)). The work may be performed either for wages or personal subsistence.
- Mark the box for “fishing work” if the work involves the catching or initial processing of fish or shellfish or the raising or harvesting of fish or shellfish at fish farms. (§ 200.81(b)). The work may be performed either for wages or personal subsistence.

**If applicable, check:*
 personal subsistence (provide comment)

- (*) Mark the box for “personal subsistence” if “...the worker and the worker’s family, as a matter of economic necessity, consume, as a substantial portion of their food intake, the crops, dairy products, or livestock they produce or the fish they catch” (§ 200.81(h)). Also provide a comment in the Comment section.

6. (Only complete if “temporary” is checked in 5a) *The work was determined to be temporary employment based on:*

- a. worker’s statement (provide comment), OR
 - Mark this box if the work was determined to be temporary employment based on a statement by the worker or the worker’s family (e.g., spouse) if the worker is unavailable (provide comment). For example, the worker states that he or she only plans to remain at the job for a few months. Provide explanatory comments in Comment section.
- b. employer’s statement (provide comment), OR
 - Mark this box if the work was determined to be temporary employment based on a statement by the employer or documentation obtained from the employer. For example, the employer states that he or she hired the worker for a specific time period (e.g., 3 months) or until a specific task is completed and the work is not one of a series of activities that is typical of permanent employment. Provide explanatory comments in Comment section. Attach supporting documentation if available.
- c. state documentation for _____ (employer).
 - Only mark this box if the state has current documentation to support that the work described in #5 is temporary employment for this particular employer. In other words, the state has verified that of those workers whose children were previously determined to be eligible based on the state’s prior determination of the temporary nature of such employment (or the children themselves if

they are the workers), virtually no workers remained employed by the same employer more than 12 months, even though the work may be available on a constant and year-round basis.

- *Employer.* Identify the employer, whether it is the name of, or code, for a farmer, a grower, a business, or a corporation, where the worker either sought or obtained qualifying work.

Comments Section. Comments must be provided for 2bi, 4c, 5, 6a and 6b of the Qualifying Move & Work Section, if applicable.

The Comments Section of the COE allows the recruiter to provide additional information or details that clarify the reasons for the recruiter’s eligibility determination. It provides an opportunity to “tell the story” if the reasons for eligibility require further explanation.

The recruiter should write clear and detailed comments so an independent party who has no prior knowledge of the eligibility determination can understand the recruiter’s reasoning for determining that the child(ren) is eligible. If applicable, the recruiter must provide comments that clearly explain items 2bi, 4c, 5, 6a and 6b of the Qualifying Move & Work Section. As mentioned previously, these items include the following scenarios:

- 2bi: The child’s move joined or preceded the worker’s move. If the child(ren) joined or preceded the parent, spouse, or guardian, record the reason for the child’s later move or the worker’s later move.
- 4c: The worker did not obtain qualifying employment as a result of the move. In this case, the recruiter must document that the worker stated that one reason for the move was to obtain qualifying work, AND
- the worker has a prior history of moves to obtain qualifying work;
 - OR there is other credible evidence that the worker actively sought qualifying work soon after the move, but for reasons beyond the worker’s control, the work was not available;
 - OR both. Examples of credible evidence include a statement by a farmer that the worker applied for qualifying work but none was available, or a newspaper clipping regarding a recent drought in the area that caused work not to be available.
- 5: The child(ren) qualified on the basis of “personal subsistence,” meaning “that the worker and the worker’s family, as a matter of economic necessity, consume, as a substantial portion of their food intake, the crops, dairy products, or livestock they produce or the fish they catch” (§ 200.81(h)).

6a/b: The employment is temporary based on the worker's statement or the employer's statement. In particular, record the information provided by the worker or employer regarding how long they expect the employment to last. The comment should be of sufficient length to adequately document how the recruiter came to the eligibility decision.

In addition, recruiters should provide additional comments on the COE in the following circumstances and in any other circumstances that require clarification or may be questioned by a third party reviewing the eligibility determination:

- The information on the COE needs additional explanation to be clearly understood by an independent outside reviewer.
- The basis for the preliminary eligibility determination is not obvious. For example, the work is unusual enough that an independent reviewer is unlikely to understand that it is qualifying work. An explanation is needed to enable a reviewer to understand how the preliminary eligibility determination was made.
- The work could be part of a series of activities that, viewed together, would constitute year-round employment (e.g., mending fences on a dairy farm and baling hay could be two parts of year-round ranching with one employer).
- The work may be viewed by an independent reviewer as either temporary or year-round employment (e.g., collecting eggs or milking cows).
- A "move" is of such brief duration or of such a short distance (or both) that one could question whether any migration has occurred (e.g., intra-city or intra-town move that is across school district boundaries).
- A parent or guardian uses a symbol such as an "X" or other valid mark as a signature.
- The person who provided the information on the COE form is not the worker.
- The qualifying move corresponds to school breaks and could be viewed by some as a return from vacation or a move for personal reasons, not a move for economic necessity whereby the worker sought or obtained qualifying work. In this case, the recruiter should explain why the move away was for economic necessity and not for personal reasons.
- The mailing address is different from the child's physical residence: provide the mailing address as a comment.
- The child(ren) and parent moved from different previous residences. Record the parent's previous *School District/City/State/Country* of residence.

Parent/Guardian/Spouse/Worker Signature. The recruiter should read and explain the following statement to the parent or guardian (in their primary language, if possible) before he or she signs the COE.

I understand the purpose of this form is to help the state determine if the child(ren)/youth listed on this form is/are eligible for the Title I, Part C, Migrant Education Program. To the best of my knowledge, all of the information I provided to the interviewer is true.

Signature, Relationship to the child(ren), Date

The interviewee signs and dates the COE on the day the interview is conducted. The interviewee must also write his or her relationship to the child.

The person who signs the COE must be the source of the information contained in the document and should verify any information provided by another source. A signature lets the MEP know that the person interviewed understands the purpose of the form and that the information provided is correct. If the parent is unable to sign his or her name, the parent must mark an “X” in the signature section and the recruiter must print the parent’s name and relationship to the child in the Comment section. If a parent refuses to sign his or her name, the recruiter must document the parent’s refusal in the Comment section and print the parent’s name and relationship to the child.

The recruiter should make sure the interviewee understands what he or she is signing. The recruiter can do this by reviewing every line of the COE and confirming with the parent that the information is correct. If the interviewee can read, the recruiter should give the interviewee a blank copy of the COE form in his or her native language (if available) so the interviewee can follow along. Once the SEA-designated reviewer reviews, signs, and dates, the COE, the MEP should send a copy of the COE by mail or hand-deliver it at a later date.

Eligibility Data Certification. The recruiter signs and dates the COE on the day the interview is conducted.

I certify that based on the information provided to me, which in all relevant aspects is reflected above, I am satisfied that these children are migratory children as defined in 20 U.S.C. 6399(2) and implementing regulations, and thus eligible as such for MEP services. I hereby certify that, to the best of my knowledge, the information is true, reliable, and valid and I understand that any false statement provided herein that I have made is subject to fine or imprisonment pursuant to 18 U.S.C. 1001.

Signature of Interviewer, Date

Signature of Designated SEA Reviewer, Date

At least one SEA-designated reviewer must check each completed COE to ensure that the written documentation is sufficient and that, based on the recorded data, the child(ren) may be enrolled in the MEP. The SEA-designated reviewer must sign and date the COE on the day it was reviewed.

NOTE: If an SEA wishes to add to any portion of the Eligibility Certification Section, it must submit its proposed statement to OME for approval.

Family Educational Rights and Privacy Act (FERPA(1974)). FERPA is a federal law that establishes the rights of parents to examine and question the content of their child’s education records and restricts the transfer of personally identifiable information from those records without written parental consent.¹ The act applies to any LEA or other educational agency or institution that receives federal funds. FERPA gives certain rights to parents regarding their child’s educational records. Programs must inform parents of their rights under FERPA and may share education records only in specific circumstances. While such a disclosure is not a required data element on the National COE, most states will add this section if space allows. **FERPA guarantees parents the right to:**

- Access and inspect their child’s educational records
- Seek to amend records in specific circumstances
- Consent prior to the disclosure of personally identifiable information from education maintained by LEAs

FERPA provides certain exceptions to the restriction of transferring education records without parental consent. One exception is when an LEA discloses information to school officials either (1) within the agency (whom the LEA has determined to have legitimate educational interests) or (2) to another school, school system, or institution of postsecondary education where the student seeks or intends to enroll. This exception applies only if the LEA notifies parents annually of this policy and certain other requirements are met.

Processing and Storing the COE

After the recruiter completes the COE, the SEA/LOA is responsible for reviewing the information on the document, and then storing and securing it appropriately. This process varies by state, but there are some basic guidelines for the recruiter and other ID&R staff. After the recruiter completes the COE, and before it is forwarded to the next person for review, the recruiter should:

- *Check the COE for accuracy.* Are all the items filled in? Are the dates of birth, QAD, and residency date correct? Are the names spelled properly? Are the recruiter’s and the parents’ signatures included? Is the writing legible?
- *Review the basic eligibility questions and eligibility determination.* Were the answers to all of the basic eligibility questions “yes?” Is it clear from the information on the COE that the child is eligible for the MEP? Were comments provided? If so, would they be clear to an independent reviewer?

After the recruiter completes these checks, the recruiter must forward the COE to at least one SEA-designated reviewer, usually a recruitment supervisor, local administrator, or other trained recruiter, who reviews the form. If the reviewer finds errors, the reviewer will return the form to the recruiter for

¹ These rights transfer to the student when she reaches the age of 18 or attends a school beyond the high school level.

corrections. If the form is complete and error-free, the reviewer signs and dates the COE to certify that, based on the information provided, each child listed is eligible for the MEP. Some states require additional reviews. Once the COE has the recruiter's and the reviewer's signatures, and it has gone through any other reviews the SEA requires, the COE is entered in the state MEP database. States that use electronic COEs generally have a comparable review process. These quality control checks help ensure that every COE is completed and that the information contained on the COE establishes eligibility under the MEP. States cannot provide services or include a child in the annual child counts reported to ED until the SEA (or its designee) has certified each child is eligible for the MEP.

COEs contain personal information that, under FERPA and some state laws, is not authorized for public disclosure. For this reason, the recruiter should check with a supervisor about policies and procedures for storing and securing COEs.

Record Keeping Requirements

Generally, records must be maintained for three years after the date the grantee or local operating agency submits its last expenditure report for the period in question (see sections 80.42(b) and (c) of EDGAR). If any litigation, claim, negotiation, audit, or other action involving the records has been started before the expiration of the three year period, the records must be retained until completion of the action and resolution of all issues which arise from it, or until the end of the regular three year period, whichever is later.

In practical terms, the length of time that an SEA/LOA must keep a COE to meet this three-year retention period depends on whether the child makes subsequent qualifying moves, which will increase the amount of time. For example, a COE that indicates that a child made a qualifying move in October 2012 means that the child will remain eligible, without another qualifying move, until October 2015. A child eligible in October 2015 would be included in the Category 1 child count for the period September 1, 2015 – August 31, 2016, and would generate fiscal year (FY) 2017 funding for the state. FY 2017 funds may be used, with carryover, until September 30, 2019. The SEA does not need to submit the final expenditure report for these funds to ED until as late as December 31, 2019. *The three-year record retention period begins in December 2019 when the SEA submits the final expenditure report and runs until December 31, 2022. Therefore, the SEA would have to keep this particular COE until December 31, 2022.* (See *MEP Guidance*, Chapter XI, Question C3). Of course, the SEA might have to keep this COE longer if there is any litigation, claim, negotiation, audit, or other action involving the record.

The SEA/LOA should ensure that records are stored in an orderly fashion and readily available if needed. By carefully maintaining and preserving MEP records, the SEA:

- Satisfies regulatory requirements¹
- Increases efficiency and saves administrative costs (both time and storage) by making it easy to locate and retrieve records
- Makes current data readily available to decision makers
- Helps document the demographic characteristics of migrant children and achievement of the MEP performance targets and measurable objectives
- Demonstrates accountability for the use of federal funds
- Protects the confidentiality and interests of migrant children

Individual State Requirements: Depending on state procedures or data-entry systems, additional instructions might apply. Recruiters should speak with their supervisors if additional instructions are required. Common ones include:

- Only trained—and, in some states, certified—recruiters are authorized to complete the COE.
- The COE should be completed legibly in blue ink to show that it is an original document, not a photocopy.
- Corrections that are made after the original interview should (1) be made in an ink color other than blue to distinguish from the original text, (2) provide the name or initials of the person making the correction, (3) provide the date the correction was made, and (4) indicate the source of all new or corrected information (e.g., the parent, the school).
- Additional comments in the comment section of the COE may be requested such as, last grade completed in home country for OSY, additional children not eligible for MEP services but who reside in the household or any safety concerns that service providers should be aware of.

Electronic COEs. Historically, the MEP has made efforts to incorporate technology into all aspects of the program and the area of ID&R has been no exception. The use of technology for documenting child eligibility is an emerging trend that states may wish to explore. Some of the advantages of using laptops, tablets, or other hardware that can be loaded with an electronic COE include:

- Electronic COEs are more likely to be completed in a standardized way. In particular, electronic COEs can be designed with drop down lists and option buttons that help how the data is received.

¹ Section 76.730 of EDGAR requires SEAs and subgrantees (including LOAs) to keep records that show (1) the amount of funds under the grant or subgrant; (2) how the SEA or subgrantee uses the funds; (3) the total cost of the project; (4) the share of that cost provided from other sources; and (5) other records as needed to facilitate an effective audit. Section 76.731 requires the SEA and its subgrantees to keep records to show their compliance with program requirements.

- The SEA can build edit and logic checks into an electronic COE that will help to identify inconsistent or illogical data relationships (e.g., comparing date of birth to grade level).
- Electronic COEs can be used for data analysis that could ultimately improve the quality of the data (e.g., the program could flag families who move north to do agricultural work in the middle of winter).
- Some recruiters can fill out an electronic COE faster than a paper COE, thus reducing the amount of time needed to complete the COE and freeing up time for other recruitment activities.
- Completing an electronic COE reduces the extra step of filling out a paper COE and then typing the same data into an electronic system.
- Electronic COEs can be linked to other data sources such as postal abbreviations for states, zip codes, lists of cities in other countries, etc.
- Having an electronic COE with a parent signature or even scanning a paper COE can reduce the number of paper files the MEP is required to maintain.
- Some people find electronic files easier to retrieve than paper files.

Some disadvantages and considerations around using an electronic COE include:

- For audit and quality control purposes, it is important for states to be able to produce a version of the COE that has all of the original data (including signatures) and to track any subsequent changes, corrections, and/or updates (by date and source). Therefore, the state must ensure that even if the most current information is displayed in the electronic database, users are able to examine the history of the COE.
- The information that is collected on the COE has to reflect the information on the national COE and has to print out in the same format (i.e., a one page document with all required data elements and sections).
- States need to be sure that parents can see what they are signing on the COE form and should make provisions for the parent to receive a copy.
- Some migrant parents may be more apprehensive about signing an electronic COE versus a paper document.
- States need to make security provisions to guard against identity theft and the release of personally identifiable information.

States should carefully weigh the advantages and disadvantages of anything new before deciding whether to adopt it, including performing a cost-benefit analysis of new technology and piloting the technology to work out any technical problems before it is fully implemented.

Lessons Learned: Completing COEs

Do Things Right the First Time. It is very important that preliminary child eligibility determinations are clearly documented. If the recruiter makes errors or does not submit complete paperwork, the work will have to be re-done. Having to re-do work delays services to children in need and costs the local MEP additional expenses which could otherwise be spent on educational services. When a recruiter does things right the first time, this saves time and money. The recruiter should always double check work before it is turned in.

Do Not Hide Mistakes. We are all human and we all make mistakes. If the recruiter finds mistakes when checking the COE, he or she should either fix them or find someone else who can fix them. The recruiter should use this experience to find ways of avoiding and/or catching mistakes in the future.

Conclusion

The COE is both a legal document and the most important document the recruiter will generate for the MEP, and it should be treated as such. The recruiter should complete the COE with care so that it is easy to read and understand and serves as a clear basis for the determination of a child's eligibility. The COE tells a very private story about a family's movement and employment. The family shares this information with the recruiter with the understanding that the information will remain confidential and that the recruiter will use it to determine whether their child is eligible to obtain needed services. Moreover, federal law requires the recruiter and other federal program staff, as well as SEA staff, to maintain the privacy of this information.

The next chapter will provide information for administrators of ID&R systems.

Recruiter Checklist

Chapter 8: Completing the Certificate of Eligibility

Did you?

- Think about how to follow the principles of proper records management?
- Review all of the information that you are required to collect in order to complete a COE meeting both the national and state requirements?
- Note situations in which you will need to include a written explanation in the comment section of the COE?
- Practice explaining the information in the parent/guardian consent block, including the provisions of FERPA?
- Confirm with your supervisor what your state's process is for reviewing and storing completed COEs?
- Find out your state's process and procedures to safely and securely store your copies of COEs?

This page left blank intentionally.

PART II:

The Administrator Manual

Chapter 9. Hiring and Training Recruiters

I don't want to forget what it's like to be a recruiter—late days and long drives. I also want my recruiters to know that I understand how hard they work. I go out with each recruiter every year so I don't forget the challenges they face every day.

Central Role of ID&R Administrators

An effective ID&R administrator understands the work of the recruiter (which is described in Part I of this manual), but also understands the unique responsibilities that come with managing a state, regional or local ID&R system. The administrator is central to the ID&R process, having primary responsibility for hiring, training, deploying, supervising, supporting, managing, and evaluating ID&R staff. The administrator also helps to develop and implement state and local policies and procedures, and to ensure the quality of eligibility determinations (including looking for defects and errors). In short, the skill of the ID&R administrator and the choices he or she makes define ID&R for the state.

The ID&R administrator's work is critical to developing and maintaining a healthy ID&R system. Because the role of the administrator is central to ID&R implementation, this chapter and the ones that follow, provide a structure for the administrator to use in managing and supervising a state, regional, or local ID&R system. Chapter 9 describes the administrator's responsibility in hiring, and provides resources for training recruiters. Chapter 10 explains the planning process for creating effective deployment and support systems for recruiters. Chapter 11 reviews the quality control requirements of an ID&R system, and strategies for managing and monitoring a local, regional, or statewide ID&R quality assurance system.

Common Responsibilities of ID&R Administrators

ID&R administrators may have different titles and may operate within different organizational structures. However, most ID&R administrators share most or all of the following common responsibilities:

- Hiring and training recruiters
- Planning recruitment and deployment of recruiters
- Supervising and supporting recruiters
- Knowing the child eligibility requirements
- Managing a quality control system
- Evaluating recruiters and improving the state's ID&R efforts
- Terminating or laying off recruiters, if needed

Among other responsibilities, the administrator's job is to ensure that recruiters are fully trained, to convene recruiters regularly to discuss eligibility scenarios, and to answer eligibility questions (or forward eligibility questions according to the state's process if the administrator does not know the answer). In addition, the administrator is often responsible for conducting outreach activities to educate school personnel, employers, and the community about the purpose of the MEP. In this role, the administrator may want to make personal contacts with key officials within local schools, employers, and key community members to pave the way for recruiters to find and recruit migrant children and youth. The administrator may write letters of introduction for recruiters that are sent or hand-delivered to these key contacts. The administrator also often serves as a liaison between the local project site and the SEA, ensuring that the policies and procedures established by the SEA are followed. The administrator ensures the reliability of eligibility decisions via state ID&R quality control measures. In addition, the administrator may determine how much time recruiters should spend on finding migrant children and their families, outreach to local employers, coordination with other programs and agencies, referrals, training and ongoing professional development, and other assigned duties. Finally, the administrator may need to establish and/or share state and local policies on issues like ethics, media contact, safety and security, sexual harassment, and equal opportunity.

Ways to Organize an ID&R System. States may choose to implement a centralized or a decentralized recruitment system, or a combination of both. In a *decentralized* system, the SEA may either delegate responsibility for ID&R to regions or LOAs or may have a state ID&R coordinator who plans and leads training activities and supports the state's recruiters, but does not directly hire or supervise recruiters. In this case, the regional or LOA administrator would hire and supervise recruiters for that region or program. One advantage of a decentralized organizational structure is that the recruiter is part of the local MEP and therefore understands how the local program works and what services are available to migrant children. One disadvantage is that the decentralized structure makes it harder to provide the close oversight and regular training that leads to a highly consistent statewide ID&R system.

By comparison, in a *centralized* system, the ID&R coordinator hires, trains, and supervises all recruiters through a central office. This centralized system results in more control and consistency, but has less flexibility, local ownership, and close communication with the local MEP. There are many ways an ID&R system can be organized; every system has its own advantages and disadvantages. Examples of common ways of organizing state ID&R systems are found in Appendix XV.

Hiring Recruiters. Finding the right person to identify and recruit eligible migrant children can be as challenging as finding the children themselves. As discussed in Chapter 2, the successful recruiter should be able to:

- Make correct preliminary eligibility decisions.
- Document child eligibility adequately, accurately, and clearly.
- Manage time wisely.
- Work independently.
- Remain flexible and adapt to a constantly changing environment.

- Represent the program effectively.
- Relate well to others and gain their trust.
- Create positive relationships with agricultural employers.
- Have good interviewing (i.e., questioning) skills.
- Maintain appropriate relationship boundaries.
- Follow confidentiality laws.
- Demonstrate personal integrity.
- Speak local migrant families' native language and exhibit cultural sensitivity.

The recruiter must be willing to drive back roads, work at night, knock on doors in poor rural neighborhoods, fend off barking dogs, and enter all types of residences alone, all for the purpose of soliciting the personal information required to fill out a COE. The recruiter's job is not for the faint of heart. Recruiters must also be able to communicate with different audiences, from recent immigrants to school administrators. It is the responsibility of the administrator to evaluate potential recruiters to see if they possess these characteristics.

Appealing to Potential Recruiters. There are a number of aspects of recruiting that many people find appealing. In particular, administrators might want to keep the following in mind when advertising a recruitment position:

- The opportunity to help children and youth in need has historically drawn good people to the migrant education community. Potential recruiters include former teachers, social workers, Peace Corps graduates, those who have worked in agriculture, and as discussed earlier, former migrant workers. It is rarely the pay that draws people to this work, but rather the opportunity to do something beneficial for migrant children and youth. This feature of the job should be emphasized when searching for applicants.
- The job of recruiting is attractive to those who like to work on their own. Many hours are spent alone driving the back roads in rural areas, looking for housing or farms where eligible families and or youth are typically found. Although this aspect of the job may sound daunting to some, it is appealing to others.
- Recruitment may interest those who are active in ethnic communities and community "connectors" who seem to know everyone, enjoy teaching "the ropes" to community newcomers, and can project a sense of trust and friendliness to new migrant workers and families.

Deciding Who to Hire. Recruiters are special people and finding the right person is a challenge for any ID&R administrator. Although the administrator should be aware of federal and state laws that govern employment and application for employment, there are some ways the administrator can evaluate these characteristics before hiring. For example, the administrator may want to ask questions like the following during the employment interview:

- How would you handle a situation like [provide a typical situation a migrant recruiter might encounter]?
- How have you dealt with someone from another culture or language background in the past?
- What kind of people do you find the most difficult to work with? Why?
- How would you describe your personality? What things give you the greatest satisfaction at work? What things frustrate you the most?
- Have you been in a situation where someone was not behaving ethically? What did/would you do?
- What is your experience with agriculture or fishing?
- How would you describe the ideal work environment?
- Have you had a project for which you had sole responsibility? How did you organize the project?
- How have you handled a problem with a boss or authority figure?

There are many other questions an administrator can ask to evaluate these skills. The administrator can also expose the applicant to the work by conducting a mock interview or showing a video about recruiting and interviewing. Whatever strategies the administrator uses to evaluate the skills of a possible recruiter, the administrator should keep in mind the following questions:

- Is the applicant a self-starter?
- Is the applicant a person of integrity (e.g., honest, no conflicts of interest)?
- Will the applicant be comfortable talking to strangers?
- Will the applicant be able to explain program services to others?
- Does the applicant have enough attention to detail to complete a COE adequately and accurately?
- Is the applicant comfortable talking both one-on-one and to small groups?
- Does the applicant speak the language of the primary local migrant population (e.g., if most of the local migrant workers are Laotian, does the applicant speak Lao)?
- Is the applicant willing to work non-traditional hours (particularly evenings)?
- Does the applicant have a valid driver's license, a dependable car, a good sense of direction, map reading and/or navigation skills?

- Does the applicant have relevant prior work experience? Has the applicant developed the skills needed to be a successful recruiter?
- Do others who have worked with the applicant have a high opinion of him or her?

Although the administrator would not have to ask all of these things of an applicant, the administrator should address them in some way through the interview and hiring process. For example, the administrator can give the applicant a list of job responsibilities like the following sample and ask if there are any items on the list that make the applicant uncomfortable.

Sample List of Recruiter Responsibilities. Although there is no all-inclusive job description for a recruiter, the following is a list of typical qualities and responsibilities that make an effective recruiter. This list is adapted from MEP Guidance. The administrator should explain that the applicant may be asked to do some or all of the following:

- Fully understand the federal law, regulations, and Guidance pertaining to the MEP.
- Follow all procedures and practices contained in the state's ID&R manual (if applicable) and in any other directives issued by the SEA.
- Identify and enroll into the MEP all eligible migrant children residing within the boundaries of the assigned school district(s) or region.
- Determine the location of migrant labor camps and housing units in the school district or region, which requires good map reading and/or navigation skills.
- Develop good working relationships with growers and other employers who use migrant labor for the purpose of identifying migrant children and youth as they move into the school district.
- Understand the cycles of seasonal and temporary agricultural employment.
- Serve as a communication link between MEP families and youth, the central district office and the schools, growers, and community agencies.
- Interview migrant families and youth in their primary language and collect and record the data that is required to enroll or update information on eligible children in the MEP and the state's student database systems.
- Certify the eligibility of children and youth to participate in MEP activities, adhering strictly to the MEP's eligibility criteria.
- Inform migrant families and youth about the MEP and FERPA.
- Have good attention to detail for completing COE forms accurately, fully, and legibly.
- Use the migrant student database to enter information and search for records.
- Maintain clear, secure, confidential, and auditable records and other information related to ID&R.
- Serve as a home-school coordinator, as requested by the local project director.

- Assist the migrant project director with the recruitment of parents for membership in the Parent Advisory Council (PAC) and with PAC activities.
- Attend training sessions.

When developing the job description, the administrator should think about how it can be aligned with the job's performance assessment (i.e., evaluation). Since the administrator is responsible for providing annual feedback on the recruiter's job performance, it is important to ensure that the successful applicant has or can learn the knowledge and skills required in the job description. Any knowledge or skill that the applicant does not have when hired can be identified as an area of growth that the applicant can work on through training. (See more information on training later in this chapter and performance assessments by supervisors in Chapter 10.) Some recruiters may work under a generic position description, so it is important that they have a full understanding of the position before they are hired.

Language and Culture. Throughout the history of the U.S., our agricultural economy has depended upon countless migrant communities. For example, in the 1880s, 75 percent of seasonal farmworkers in California were Chinese. The next wave of farmworkers were new Asian immigrants from Japan and the Philippines, soon followed by laborers from British India. On the East Coast, French Canadians, Caribbean Islanders, and Europeans labored in U.S. fields. One of the greatest internal agricultural migrations to date was during the 1930s infamous Dust Bowl migration where hundreds of thousands of Midwestern families moved west due to severe drought. Low-income native whites and African Americans made up much of the migrant labor pool for the early part of the 19th century. In the southern U.S. particularly, African Americans have made great contributions to the migrant farm labor economy. However, as World War II intensified, so did the need for the U.S. to grow food. From 1942 to 1964, the U.S. enacted the Mexican Farm Labor Program—commonly known as the “Bracero Program”—which brought between one and two million Mexican agricultural workers to the U.S. Since the 1980s economic crisis and internal conflict in much of Latin America has pushed workers north in search of a better life, landing them employment in the U.S. agricultural farm labor workforce.¹

While much of the agricultural farmworker population has remained Latino for the last six decades, there are increasing pockets of micro-migrant communities across the country. It can be difficult for MEPs to hire recruiters who represent every cultural and language group within the migrant population. Moreover, because the population itself changes as a result of economics and cultural migration, programs may find themselves with linguistically and culturally “outdated” personnel within a few years. This can be a serious challenge for the local administrator who strives to employ culturally competent staff for the MEP.

For example, in Pennsylvania there are several concentrations of ethnically diverse migrant groups within a relatively small geographic area. In particular, businesses in Philadelphia, a Mid-Atlantic receiving city, employs workers from Korea, Cambodia, China, Vietnam, Nepal, Burma, Indonesia and other Asian countries. Many of these individuals migrate to the U.S. and obtain qualifying work in

¹ Bread for the World Institute. Briefing Paper, number 12, December 2011. Retrieved from <http://www.bread.org/institute/papers/farm-workers-and-immigration.pdf>. January 4, 2012.

temporary or seasonal employment following their move. In all, more than ten different languages and countless cultures reside in one geographic area. To hire, train and deploy a culturally competent recruitment team takes ingenuity and logistical planning from a recruitment administrator.

Since the MEP provides services to families and youth from many different cultures and countries, the issues of language and culture are particularly important when hiring recruiters. There are many benefits of hiring recruiters who are of the same cultural or language group as the families being served. For example, since the majority of migrant children are Latino, MEPs often try to hire bilingual Latino recruiters to increase the effectiveness of their recruitment efforts and improve communication with migrant families. While speaking the same language and understanding the culture of local farmworkers may help facilitate the recruitment process, it can also present a hiring challenge to the administrator if there is a limited pool of qualified candidates who are comfortable with the language and culture or if there are many language and cultural groups represented in the community.

One possible solution is for the administrator to consider hiring former migrants whose life experiences are similar to current migrants and who, because they understand the culture so well, may be better able to assess the needs of the target population. In cases where a former migrant has a strong network within the migrant community, but does not have the English language literacy skills needed to adequately and accurately complete a COE or other required paperwork, the program can try to pair the former migrant with an experienced recruiter who would fill out the COE and other paperwork. In this way, the program has the benefit of the former migrant's language skills and credibility in the migrant community yet also ensures that eligibility determinations are documented properly. The MEP can also provide professional development opportunities and English language training to help the former migrant gain the skills needed to properly document a child's eligibility for the MEP.

The recruiter who is not of the same language, cultural, or ethnic background as the local migrant population can still be highly effective. A caring and nurturing person who is trusted by the migrant community often makes an exemplary recruiter. When the recruiter is concerned about the welfare of local migrant children, that concern is often apparent to migrant families. The recruiter who does not speak a family's native language often becomes adept at using interpreters and translators to obtain information and to communicate with migrant families. However, it is important that the recruiter understands and respects the language and culture of the families and makes a significant effort to establish networks within the migrant community. Taking the time to learn basic greetings and salutations for the various languages of the local migrant population is one way to gain rapport.

Providing Training

My job as an administrator is to make gray areas black and white for my recruiters. I try to give clear, simple answers to their questions.

Once the administrator has hired recruiters, the administrator should provide or arrange for training on how to develop individual ID&R action plans, interview families, and complete COEs. Recruiter training programs should be comprehensive and ongoing. Recruiting, like agriculture, is a changing field and, as a result, the administrator should make a long-term commitment to constantly train and re-train recruiters to keep their skills and knowledge up-to-date.

The National ID&R Curriculum. OME has developed an ID&R curriculum that describes the basic knowledge and skills that the OME believes a recruiter needs to master in order to properly identify and recruit migrant children and make preliminary eligibility determinations. The curriculum is made up of eight modules that correlate with one or more chapters of the National ID&R Manual. Each module consists of 1-3 levels that are the training framework for the following five objectives:

1. State and local MEP recruiters understand the background of the MEP, the ID&R process of the MEP, and the duties and responsibilities of the recruiter.

The first objective covers the purpose, basic history, and organization of the MEP. In addition, the recruiter learns the basic eligibility criteria and the general process for ID&R. The recruiter is also made aware of his or her basic duties and responsibilities.

As discussed in Chapter 1 of this ID&R Manual, the administrator often finds that the recruiter does a better job if he or she understands how the recruiter's work fits into the national, state, and local vision for migrant education. For this reason, objective one provides a complete picture of the fundamentals of the MEP, thus laying a solid foundation for a new recruiter.

2. State and local MEP personnel implement practices that result in the efficient ID&R of migrant children and youth.

The second objective teaches the recruiter how to develop a recruitment network. The recruiter learns how to determine where migrant families and youth live and work, and gains the knowledge and skills to find them. The recruiter practices how to explain the MEP to migrant families and youth and learns the major agricultural and fishing work in the local area.

3. State and local MEP personnel implement practices that result in reliable and valid child eligibility determinations.

In this third objective, the recruiter will thoroughly understand the basic eligibility requirements for the MEP as found in the law, regulations, Guidance, and state handbooks or policies. The recruiter will also learn the knowledge and skills to effectively interview a family or youth in a culturally competent manner.

The recruiter may be the first and perhaps only MEP staff member who migrant families and youth will meet. Additionally, for many parents, the recruiter sets the tone for the home-school relationship. For this reason, it is imperative that the recruiter has a diverse understanding of all MEP eligibility requirements and is able to explain the MEP in a manner which migrant parents and youth understand. The recruiter must be able to strike a balance between the many MEP formalities such as COE completion and quality control measures, while simultaneously maintaining a casual enough presence that puts the migrant family or youth at ease.

4. State and local MEP personnel are aware of and adhere to ethical standards of behavior in child eligibility determinations.

In the fourth objective, the recruiter will learn the ethical behaviors that are expected in determining the eligibility of a child or youth. Additionally, the recruiter will understand why it is so important to make proper eligibility determinations, and what can happen to the recruiter and to the MEP if decisions are not made properly. Finally, the recruiter will know what action is expected if he or she is asked to do something that makes him or her uncomfortable, and how to report suspected cases of fraud, waste, or abuse.

The administrator should consider developing an ethics statement and standards (see Appendix VII). To teach these concepts, the trainer may want to have recruiters work through case studies and discuss whether particular practices are legal and/or ethical and how they should be resolved.

5. State and local MEP personnel implement practices that strengthen coordination and collaboration between migrant families and youth, the school(s), and the community.

In this final objective, the recruiter will learn how to facilitate coordination and collaboration among migrant families, the school(s), and the community. The curriculum training for this objective allows the recruiter the opportunity to practice meeting planning, facilitation, and team building.

A recruiter must wear many hats. Recruiters who understand the importance of case management, while continuously teaching self-advocacy skills to the families and youth they serve, is a best case example for an administrator. Because the MEP is a supplemental educational program it is vital that recruiters learn to collaborate and partner with other organizations to share the workload. One way recruiters can expand their services is by promoting the MEP to like-minded agencies. To do this recruiters need a firm understanding of basic coordination principles and the professional skills to facilitate the process. Objective five covers the fundamentals for strong coordination, team building, and the positive promotion of MEP services.

National ID&R Curriculum Summary. As outlined above, each of the five objectives can be found throughout the modules of the National ID&R Curriculum. The content of each module is taught through research-based instructional strategies designed to meet the needs of all learners. Each module consists of 1-3 levels allowing the SEA the option of selecting specific topics to train based on the composition of the audience. Level 1 will provide the basic information for the module topic, which makes it ideal for new recruiters and/or migrant staff members, or to use as a refresher for veteran recruiters. Subsequent levels provide additional topics of study related to the module for follow-up or in-depth trainings.

The curriculum identifies what OME believes to be the knowledge and skills that a recruiter should have to successfully perform his or her job. It serves as a framework for training developed by OME, and as a guide for state programs to use in developing their own training.

The ID&R curriculum also suggests knowledge and skills that state trainers may wish to consider in developing their individual ID&R training. For example, the recruiter should learn:

- Basic information about the local MEP (e.g., services, dates of operation, hours, and contact information)
- The organizational structure and policies of the state and local ID&R system
- The content of existing local and state ID&R plans
- The characteristics of local migratory agricultural workers or fishers and their children, and their mobility patterns
- Agricultural employer locations and contacts
- Organizations with which the state or local education agencies expect the recruiter to coordinate with and the time allocated to this coordination
- Methods of collecting and maintaining data on migrant children and youth
- His or her role in the state's quality control process and how to assist in developing and implementing the state or local plan for quality control, as needed

States may also find it helpful to educate the recruiter on case law that affects migrant children, such as the right to a free public education regardless of civil status (*Plyler vs. Doe*) and the right to a meaningful opportunity for ELL students to participate in school programs (*Lau vs. Nichols*). For more information on relevant legal issues, see Appendix I. States may also want to provide training on specific state or local laws or regulations that directly affect migrant families or ID&R, like those on child abuse and neglect and truancy (see Appendix I).

Regardless of a state's size, location, agricultural and/or fishing industries, or the migrant communities demographic makeup, a recruiter training is always a combination of classroom training, independent study, and field-based training.

Classroom Training. The administrator is responsible for ensuring that the recruiter is trained on the basic information and skills he or she will need to do the job effectively (See Chapter 3). While the ID&R Curriculum described previously in this section is the most comprehensive classroom training available, for many states it is simply not feasible to administer the entire curriculum prior to deploying the new staff. The administrator will often need to decipher which modules to utilize for the limited training window they have. Administrators must pick and choose which modules and training methods work for their state and design an appropriate training accordingly. The curriculum is designed to be used for any initial recruiter trainings and throughout the year as needed.

Independent Study. The administrator should encourage the recruiter to study key documents on his or her own. In most cases, an initial recruiter training will range from a few days to a weeklong event. A typical recruiter in training may spend two days in the classroom, two days in the field, and finish with a final day back in the classroom. If this training straddles a weekend, this is the ideal time for independent study. Additionally, new recruiters should anticipate that the evenings during the week of training will require independent study. In particular, the administrator should encourage the recruiter to review:

1. The applicable law and regulations (including the instructions to complete the National COE);
2. The Guidance, which is available online at <http://www2.ed.gov/programs/mep/legislation.html>;
3. This ID&R Manual;
4. The state's ID&R manual, where available;
5. Applicable state and local laws, regulations and policy guidance; and
6. State and local ID&R action plans (more information on this topic is available in Chapter 5).

The first few months on the job are the ideal time for intensive independent study. This is the time the new recruiter formulates individual recruitment strategies. The stronger his/her comprehension is on MEP policy and background, the more likely it is the new recruiter will become a competent member of the ID&R team for years to come.

Field-Based Training. No recruiter training is complete without field-based training. For many new recruiters, field-based training will be the most eye opening and valuable component of their learning experience. A classroom setting can only teach so much; to really learn the ropes of recruiting, one must enter the field with an experienced mentor to observe, learn, and absorb the full spectrum of the job. Information on field-based recruiting (mentoring and peer coaching, teams and peer networks) is discussed later in the next chapter in the section entitled “*Supporting Recruiters.*”

In my experience, the recruiters who make the most errors when recruiting migrant families are either those who are brand new, because they don't have enough knowledge or experience yet, or those who have been around for a long time who haven't kept up with changes to the eligibility requirements.

Advanced Eligibility Training and Ongoing Professional Development. The administrator should provide advanced eligibility training and ongoing professional development to help the recruiter keep abreast of changes to the law, regulations, policies, and procedures that affect the eligibility of migrant children and to update and improve the recruiter's knowledge and skills. The recruiter who does not participate in ongoing eligibility training is more likely to make mistakes when determining child eligibility than the recruiter who takes regular "refresher" courses. Some topics for advanced training might include:

Changes to child eligibility requirements. The administrator should offer experienced recruiters periodic reviews of basic child eligibility requirements to keep them sharp. In particular, this training should focus on any changes or revisions to federal, state, and local laws, regulations, policies, and procedures that affect the eligibility of migrant children and youth.

Determining child eligibility in difficult cases. The administrator should address any problems identified through the prospective re-interviews, the most frequently asked questions that arose during the year, and any emerging issues that require further study or training. The focus of all eligibility training should be on topics that affect the eligibility status of many migrant children rather than unusual situations that affect a small number of children (see Chapter 7).

Strengthening the recruitment network. The administrator may wish to train on advanced strategies for developing recruitment networks across the state, and have skilled and experienced recruiters share techniques they have found to be effective at building relationships with employers and other key contacts. Over time, experienced recruiters can develop a set of "best practices" for building a recruitment network that can be shared with new recruiters.

Improving interview skills. It is important to provide periodic coaching and feedback to individual recruiters on their interview skills through mock interviews or other guided practice. The administrator should also regularly review the *Sample Interview Script* (see Appendix VIII) with the recruiter and discuss any needed changes or training. Finally, the administrator may want to cover issues that recruiters have encountered during interviews with migrant families (e.g., information or resources that migrant families need, concerns expressed by migrant families). If recruiters need support materials (e.g., a brochure that describes the local MEP, information on local human services organizations), this time in discussion and review with the administrator could also be used to plan how to develop these materials or how to get them through other sources.

Common mistakes made by recruiters in completing COEs. The administrator should cover the most common errors identified through the state's quality control system, as well as any new state or local procedures that have been developed to keep the recruiter from making these errors.

Ethical dilemmas. The administrator should cover situations that have arisen throughout the year that raised questions regarding how to respond ethically. The administrator should also address questions raised by recruiters and provide time to discuss or role-play possible responses. Recruiter generated questions can be used to develop scenarios for training new recruiters (see Chapter 7).

ID&R coordinators and key ID&R staff should make a point of attending local, regional, statewide and national trainings when possible as part of their ongoing professional development.

Developing a State or Local Training Curriculum. The initial training provided to the new recruiter is essential to his or her future success and can help ensure that eligibility determinations made in the recruiter's first year are correct. Experienced ID&R staff report that most eligibility mistakes are made by the rookie recruiter, which highlights the importance of effective initial training. As mentioned earlier, experienced recruiters can also make mistakes if they do not stay abreast of changes to eligibility requirements and evolving "best practices" in ID&R. Therefore, it is important to provide ongoing advanced training as well.

Before an administrator begins to develop a training curriculum or to expand on the national ID&R Curriculum available at <http://RESULTS.ed.gov>, he or she should ask the following questions:

- Has sufficient time been set aside to train new recruiters?
- Does the program have copies of the federal law, regulations and Guidance that pertain to the MEP (if not, they are available on the ED's website at <http://www2.ed.gov/programs/mep/legislation.html>)?
- Does the program have a pre- and post-assessment that can be given to new recruiters to find out what they already know and help focus the training on their specific training needs (as well as to measure their increased knowledge)?
- Is the state ID&R manual up-to-date and ready to be used as a primary source of guidance for new recruiters?
- Has the program developed or borrowed interesting learning activities (such as games, role plays or mock interviews) that can be used to reinforce eligibility rules and interviewing skills?
- Has the program determined how to select, train and support mentors? (See Chapter 10.)
- Is the program prepared to respond to questions that new recruiters will have after they begin their work?
- Has the program developed standards for what a recruiter needs to know before being allowed to make preliminary eligibility determinations and a way of assessing that the recruiter has met the standard?
- Does the training incorporate a combination of classroom, field-based training, and independent study?
- Has thought been given to how to evaluate whether recruiters have learned what the curriculum is designed to teach?

In developing a training program, the administrator might consider the following strategies and issues:

- *Establish objectives and learning outcomes.* It is important for the administrator to determine what the new recruiter should *know* and *be able to do* at the end of the training. The training activities should then be designed to teach these key concepts. The administrator should also develop a method of assessing how well the recruiter learned what the sessions were designed to teach.
- *Connect training with prior learning.* The recruiter does not come to ID&R training as a blank slate waiting for the trainer to write on it. Instead, the recruiter comes with a rich set of skills and experiences that are often related to the work the recruiter will do in the MEP. A skillful trainer will connect new learning with experiences that the recruiter may have had in the past. This connection is valuable because it recognizes what the recruiter already knows, it can reduce the amount of time needed to teach the new skill, and the recruiter may have insights from prior experience that could benefit the state.
- *Provide opportunities to practice.* Conventional wisdom says that learners are more likely to remember things that they have done than things they have read, heard or seen. A good training strategy is to present new material to recruiters, followed by both guided and independent practice with corrective feedback. For example, the trainer could (1) explain the key components of an effective interview, (2) model an interview and let participants discuss whether all of the components were included and how the interview could be improved, and (3) have participants practice interviewing each other, using the key components being taught. In all cases, the trainer should provide corrective feedback and guidance until the participant masters the content of the lesson.
- *Paint both a big and small picture view.* The new recruiter benefits greatly when they have a general understanding of the larger migrant farmworker community and the current local MEP student population. Providing a historical context for the MEP while telling the local state story enhances a recruiter's perspective about the job. It is easy to get bogged down in the policy components of the ID&R system, overwhelming a new recruiter with too much legal jargon. It is also important to not simply train about the big picture, focusing solely on the plight of migrant workers without clarifying the MEP eligibility criteria and target audience will surely lead to erroneous recruitment. The best trainings prepare a recruiter to step into the local MEP environment with a strong understanding of the program's foundation.
- *Ask questions beyond "Yes" and "No."* It is common for new staff to want to please their administrators. For example, if the trainer reviews the ID&R guidance and then asks the new recruiter, "Do you understand what is considered a reasonable timeframe to conclude a worker obtained qualifying work 'soon after a move'?" The response is often a simple "Yes." Instead of asking "yes" or "no" questions, the administrator should ask more in-depth, open-ended questions. For example, asking a question like "What is the general timeframe a worker needs to obtain work to be able to conclude that the worker obtained qualifying work 'soon after the move'?"

This question encourages the new recruiter to think through the answer and respond with specificity. This approach is a good check for how well the new recruiter understands the nuances of eligibility and gives the administrator immediate feedback on the effectiveness of the lesson.

- *Check for understanding.* Some common strategies that the administrator can use to check for understanding are repeatedly identified by Sharon Bowman in her many articles and publications. Her most recent book titled, *“Using Brian Science to Make Training Stick! Six Learning Principles the Trump Traditional Teaching”* states that in terms of learning when a participant physically moves around, sees images, practices the lesson with writing, is taught in short examples and in several different ways learning increases.¹ One example that is utilized throughout her teachings is the “repeat back” method. Here as it applies to MEP, administrators can ask recruiters to “repeat back” the information they have just learned; this not only checks whether the recruiter can recite the information accurately (thereby allowing the administrator to correct miscommunications quickly), but the process of repeating the information helps the recruiter retain it better. Administrators can also have recruiters “play back” information in the form of role plays and skits that act out learning objectives; extroverted trainees usually enjoy this technique. Introverted recruiters prefer to demonstrate their understanding through “think-back” activities, where they can consider learning objectives on their own and then share their thoughts in a reflective manner. Often the best way to check whether the recruiter understands the learning objectives is to “teach back” the material that was learned by instructing a fellow recruiter. The recruiter learns the objectives by explaining them to someone else. Finally, an administrator can check for understanding, and the quality of training, by asking recruiters-in-training to “report back” on how they are using their learning in their everyday recruiting activities. By getting feedback in various forms, the administrator or trainer can be sure that the recruiter thoroughly understands the training objectives.
- *Adapt training for ELL recruiters.* The administrator should know whether the new recruiter is an ELL. As language acquisition research reveals, many people learn to speak a new language before they are able to grasp complex content, especially when reading. The administrator can benefit from consulting a teacher who has experience with ELL strategies to review and revise the training agenda and activities, where needed, and to consider ELL recruiters’ different learning styles and ability to grasp verbal and written material.
- *Make it fun.* Memorizing rules and regulations can be an arduous task and much of the training for the new recruiter focuses on specific, and sometimes complex, policy. In order to make the training more effective, the administrator should develop fun, interactive training activities. Adapting versions of popular game shows, word games, and board games are just a few strategies the recruitment administrator can use to make learning fun. The administrator can check with other states to see what games

¹ Bowman, S. *Using Brian Science to Make Training Stick! Six Learning Principles the Trump Traditional Teaching*. (Glenbrook, NV: Bowperson Publishing, 2011), 15.

and similar strategies (simulations) they have developed and which have been the most successful.

- *Evaluate.* The training is not a success unless the recruiter learned what the curriculum was designed to teach. At a minimum, the recruiter should learn how to use tools like the *Basic Eligibility Factors Chart* and the *Sample Interview Script* to make a correct preliminary eligibility determination. A simple pre- and post-survey about the basic eligibility criteria with room for scenario-based eligibility determinations is very informative for an administrator to gauge the recruiters training comprehension. This not only confirms they grasped the concepts but it also provides a concrete assessment of what further training is needed. A well informed and approachable administrator/supervisor yields competent recruiters. Be sure recruiters know their questions are valued and be sure they know who to call when questions arise.

Conclusion

The administration of an ID&R system and supervision of recruiters can be challenging. The administrator needs to find the right people, and provide them with high-quality training. Hiring under-qualified candidates as recruiters and not providing adequate training can lead to significant errors that can take a great deal of time to correct and may result in the MEP having to return funds. Chapter 10 provides additional information on the planning and deployment of recruiters, as well as ideas for supporting recruiters in their work.

Recruiter Checklist

Chapter 9: Hiring and Training Recruiters

Did you?

- Develop guiding questions and a job description to use when hiring recruiters?
- Establish learning objectives for recruiter training (what a recruiter should know and be able to do at the end of the training)?
- Develop a training plan for new recruiters?
- Incorporate classroom, field-based and independent study opportunities into the training?
- Develop advanced eligibility training and ongoing professional development for seasoned recruiters?

Chapter 10. Planning ID&R Deployment and Supporting Recruiters

Planning Recruitment and Deploying Recruiters

In some ways, the administrator's role in planning recruitment activities and deploying recruiters mirrors the role of the local recruiter. Chapters 4 and 5 of this manual discuss the recruiter's role in conducting research, building a recruitment network, and developing an individual ID&R action plan. The administrator, who does much of the same work at a state, regional or local level, can refer to these chapters for more information.

Planning. In order to develop an effective ID&R plan, the administrator needs to understand the agricultural and migration patterns in the state or local service area. Chapter 4 of this manual provides the essential questions that the administrator needs to answer through careful research. For example, the state should assemble a statewide information database on common crops and qualifying activities, dates of growing and harvesting seasons (which may coincide with peak arrival and departure times for migrant workers), locations of major employers, etc. Not only is this information useful to recruiters, it is also essential to know when and where to deploy the state's recruitment workforce. Some ID&R systems are able to plan "from the top down," and produce useful information to disseminate to local sites across the state. Other states compile information developed by their local project sites. In these cases, the administrator should carefully review the quality and consistency of the information provided before distributing it to others.

In planning ID&R efforts, the administrator also has a unique opportunity to build relationships that can help the MEP statewide. Building a state network and promoting the program at the regional and state level with major employers, schools, community and commercial organizations, and government agencies can expand the reach of the MEP. Administrators should also consider developing statewide and regional promotions that will support local recruitment efforts, like developing a state MEP brochure or developing radio spots on the MEP. Promotional ideas are provided in Chapter 4. The administrator's next step is to decide, with input from recruiters, when, where, and how to focus the state's ID&R efforts.

Deployment. The administrator is responsible for the statewide deployment of ID&R staff, and should develop a strategy or action plan for deployment. Chapter 5 gives specific guidance on how to develop a state, local, and individual ID&R action plan. Here are some questions an administrator should consider in deploying recruiters:

- Where are the largest concentrations of migrant children and youth in the state?
- What does the state currently do to find migrant children and youth? How does the state know that these activities are working?
- Does the SEA employ a statewide recruitment coordinator?
- Who generally has the primary responsibility for field-based ID&R activities at the local/regional level? How many local/regional recruiters are employed across the

state? How many are employed year-round versus summer-only? Do most recruiters spend all of their time recruiting or do they recruit part-time in conjunction with other MEP responsibilities? What other types of job responsibilities do project recruiters usually have?

- Does the SEA have an ID&R manual? How is it updated and improved?
- What are the primary methods used by local MEP recruiters to identify and recruit migrant students? How much effort is made to identify and recruit previously unidentified migrant students?
- Are there areas of the state that do not have migrant projects? Does the state survey these non-project areas periodically? How are these surveys done?
- What agencies and data sources does the SEA coordinate with to determine where migrant families reside? What activities are coordinated? Do other organizations conduct recruitment activities for the state?
- What are the most common qualifying activities? What are the best times of the year to recruit? Where do most migrant families move from/to?
- Do the local MEPs collaborate well with agricultural and fishing employers? What is the overall relationship like with agricultural and fishing employers across the state? Do we work to enhance these relationships?
- Is the number of identified migrant students increasing or decreasing? Where and why?

An ID&R action plan that addresses questions like these will help to guide the state's ID&R efforts. It will also assist the individual recruiter in planning his or her individual recruitment efforts. Finding all eligible migrant children and youth is the state's responsibility; therefore, recruitment staff should first be deployed in agricultural areas where migrant workers are located, or near housing where the families and youth may reside. Since the MEP has limited resources, it is necessary to prioritize where to deploy recruiters.

Supporting Recruiters

Mentoring and Peer Coaching. Recruiters can learn a lot from fellow recruiters. Whenever possible, an administrator should provide a knowledgeable, skilled, and experienced mentor for each new recruiter. The administrator should be aware that being a good mentor can be challenging and time-consuming and takes careful planning. In particular, the administrator should consider the following:

1. How to select and train competent mentors;
2. What incentives to offer, for example, reduced workload, additional compensation, or public recognition;
3. How to match mentor recruiters with new recruiters;
4. How frequently mentors and new recruiters should meet;
5. How long (i.e., duration) the mentoring relationship should last;

6. What mentoring guidelines, responsibilities, expectations, roles, suggested activities, tips, and/or agreements are needed; and
7. How to evaluate and improve the mentoring program over time.

Ultimately, the administrator may wish to develop a certification program for mentors so only those recruiters who have demonstrated a high level of knowledge of child eligibility requirements and have good interpersonal skills are eligible to be certified as mentors.

When recruiting mentors, some of the benefits of the mentoring relationship that the administrator might want to point out include:

- Having the personal fulfillment that comes from helping a peer become successful
- Helping the MEP to better attract and keep good recruiters
- Helping the mentor remain well-versed on eligibility requirements and current issues in ID&R
- Expanding the mentor's network by meeting members of the new recruiter's network
- Seeing the mentor's experience and knowledge continue after the mentor retires or leaves the job¹

A primary component of the mentor's responsibility should be to take the new recruiter on recruitment visits to provide multiple opportunities for the new recruiter to observe how to properly conduct an eligibility interview. This provides the new recruiter with an opportunity to see how the mentor makes the initial contact with a migrant family or youth, explains the migrant program to parents and other family members, conducts an interview, and handles problems or questions that arise during interviews. Whenever possible, have the new recruiter observe more than one experienced recruiter and try to emulate the strengths of each. After observing several interviews, the new recruiter should be encouraged to conduct part of the interview, with the mentor's help and support. As the new recruiter's interviewing skills improve, the new recruiter should be encouraged to take over more of the interview to become comfortable interviewing a family or youth.

Here are some tips that administrators may want to provide to mentors:

- *Be available.* New recruiters may be reluctant to ask questions if they think they are interrupting the mentor or using too much of the mentor's time. The mentor should have an open door policy.
- *Be clear.* New recruiters may not know what questions to ask or may be confused by common acronyms and terminology. The mentor should clearly describe the responsibilities of the position, using words that the new recruiter will understand.

¹ National Academy of Science, National Academy of Engineering, and Institute of Medicine, *Adviser, Teacher, Role Model, Friend: On Being A Mentor To Students In Science And Engineering*; [online book], available at <http://www.nap.edu/readingroom/books/mentor/>. (March 30, 2012).

- *Encourage cultural sensitivity.* The mentor should teach the new recruiter how to work with all of the ethnical and cultural groups found within the local migrant community.
- *Point out pitfalls.* The mentor should alert the new recruiter to problems that may occur when recruiting and give ideas and strategies for avoiding or resolving these problems.
- *Encourage trying new skills.* When the mentor thinks the new recruiter is ready, the mentor should encourage the new recruiter to try out new skills.
- *Be constructive.* The mentor should provide the new recruiter with constructive and supportive feedback. Criticism should be tempered with legitimate praise. The mentor should also welcome suggestions from the new recruiter on how to do things better and faster.
- *Encourage self-sufficiency.* Eventually, the new recruiter will have to begin conducting interviews on his or her own. The mentor should help build the new recruiter's confidence and decision-making skills.
- *Model good time management.* The mentor should model efficient strategies for finding and recruiting families.
- *Provide introductions.* The mentor should introduce the new recruiter to members of the mentor's recruitment network, and also be open to meeting members of the new recruiter's network.
- *Encourage ethical behavior.* The mentor should talk with the new recruiter about professional ethics and demonstrate ethical behavior.²

The new recruiter may want to work with more than one mentor, and mentors may want to work with more than one new recruiter. A new recruiter should be encouraged to find several mentors, each with a different skill or knowledge that the recruiter wants to learn, instead of expecting a single mentor to have expertise in every topic.³

Having an experienced recruiter accompany the new recruiter can help the new recruiter gain confidence and get early feedback on his or her interviewing skills. Mentors and peer coaches should be encouraged to take on a range of roles with the new recruiter, including teacher, networker, sounding board, confidence builder, role model, rapport builder, listener, questioner, source of inspiration, explorer of options, etc.

² Ibid.

³ University of Michigan, Rackham Graduate School, *How to Mentor Graduate Students: A Guide for Faculty in a Diverse University*, [online book], 16, available at <http://www.rackham.umich.edu/downloads/publications/Fmentoring.pdf> (Accessed: July 30, 2012).

Teams and Peer Networks. The recruitment administrator should use team-building strategies to help the recruiter feel like part of the MEP family. The recruiter is a member of two basic “teams.” The first is the *recruitment* team, which includes the state ID&R coordinator, other administrators directly involved in recruitment, peer recruiters with whom the recruiter was trained, experienced recruiters, and data entry specialists. The second is the staff of the local MEP, which may include a local administrator, instructional and other direct service staff, and support personnel. This group may be school-based or may work independently from the local district.

Recruiting can quickly become an isolating job without a pre-established support team. Recruiters often find it essential to meet regularly with peer recruiters to share tips, discuss problems and network. It is important to establish a “safe” learning environment where the recruiter feels free to share and to learn from both successes and failures. The recruiter may find it useful to work with a team when developing or updating an individual ID&R plan. The recruiter should be encouraged to try new and promising ID&R strategies and to share the results (both good and bad) with peers. In this way, the whole ID&R team will continually learn and improve.

Here are some basic team building strategies that the administrator can use:

- *Establish common group goals.* It should be relatively easy for the recruitment team to identify common goals in the areas of finding, identifying, and enrolling migrant children. The common experiences of looking for migrant families, working through the rules and regulations governing ID&R, driving in rural areas, completing paperwork, etc., can unite the group.
- *Use teamwork to attain these goals.* A good team can help the recruiter find migrant children and youth. For example, the local MEP team can provide leads on families who might have eligible children, and can build the credibility of the MEP by providing quality services to those enrolled in the program. The recruitment team can provide advance notification when migrant families move to another recruiter’s area.¹
- *Recognize that team members can be their own best problem-solvers.* Bringing in “experts” to solve recruitment problems is often not the best solution. A strong team of people with common goals can often be more effective than an outside expert.²
- *Instill strong leadership.* The administrator should remember that team building starts with strong leadership, so it is important that the team leader receive the training, coaching, and on-going support needed to drive the effort. The administrator can draw from a number of team-building resources in the areas of leadership, diagnosis of individual team member strengths and weaknesses, team building activities, and ongoing team improvement. The administrator should consider arranging team-building training to learn how to increase the effectiveness of recruiters.

¹ Team Technology Co. “Team Building: A Basic Definition,” [online article], available at <http://www.teamtechnology.co.uk/tt/h-articl/tb-basic.htm>. (March 30, 2012).

² William G. Dyer and Jeffrey H. Dyer. *Team Building: Proven Strategies for Improving Team Performance*. (San Francisco, CA: Jossey-Bass A.Wiley Imprint, 2007), p. 4-5.

- *Provide recognition.* The administrator can help to motivate recruiters through positive reinforcement, such as public recognition and awards based on performance (i.e., having a low number of defective COEs, making numerous personal contacts with potentially eligible children or with members of the recruiter's network). The administrator should emphasize the *quality* of child eligibility determinations over the *quantity* of such determinations. The administrator should avoid using recruitment quotas as an incentive (i.e., the number of migrant children recruited each month). Such pressure could lead to making inaccurate eligibility determinations.

Evaluation and Improvement. An important part of any training program is evaluating the quality of the program and continuously making improvements. The most important evaluation of a recruiter training program is the extent to which the recruiter is making correct preliminary eligibility determinations. This is determined by the state's quality control system (see Chapter 11). Other methods of evaluation include measuring whether:

1. Training activities have led to more efficient ways of finding migrant families;
2. Training was implemented as planned;
3. Training goals were met;
4. Recruiters were satisfied with the training; and
5. The training program is improving over time.

Just as the recruiter is encouraged to participate in professional development activities, the administrator should also take advantage of professional development opportunities such as the OME Annual Conference and other national trainings and conferences. It is also important to hold ongoing state and regional meetings to coordinate efforts and communication across the network.

The administrator is also responsible for evaluating the performance of individual recruiters. Some of the things that an administrator should consider when evaluating a recruiter is whether he or she:

1. Makes correct eligibility decisions;
2. Documents child eligibility adequately, accurately and clearly;
3. Manages time wisely;
4. Represents the program effectively;
5. Relates well to others;
6. Has good interviewing (i.e., questioning skills);
7. Demonstrates personal integrity;
8. Exhibits cultural sensitivity; and
9. Meets both team and personal goals.

Meet with Recruiters Regularly and Assess Performance. MEP regulations require SEAs to supervise and annually review and evaluate the ID&R practices of individual recruiters. They can accomplish this

by carrying out the task themselves or delegating the responsibility to the regional or local level. A supervisor who meets regularly with recruiters will be in a good position to review and evaluate recruiter performance. These meetings provide an opportunity to discuss any child eligibility questions the recruiter might have and to find ways to increase the quality and efficiency of the ID&R system. In addition, these meetings provide an opportunity to reinforce what the supervisor sees as the recruiter's primary job duties and responsibilities, so recruiters do not spend too much time on activities that the supervisor sees as being less productive than others. The supervisor should make a point of meeting with the new recruiter to answer questions, show interest in the recruiter's work, and to provide support and guidance during those important early weeks on the job. For recruiters who work in isolated areas, these meetings could be done through weekly or bi-weekly telephone calls and as questions arise.

It is also important to observe recruiters and provide feedback and guidance on their interviewing and other skills. If the recruiter is not meeting the supervisor's expectation, the supervisor should develop a coaching and improvement plan.

Layoffs or Terminations. The administrator may be required to lay off recruiters because of reductions in funding or changes in the migrant population, or to terminate a recruiter because of performance. In all cases, the administrator should follow the policies and procedures established by the state program or local project.

Conclusion

Developing and executing a solid ID&R plan, while providing regular supervision and team-building, can be a difficult task for the ID&R administrator. Problems with recruitment put the MEP at risk. Providing recruiters with the resources and support they need and deserve provides reassurance that the children identified and served are truly eligible and in need of services. Chapter 11 provides information to administrators about quality control and ID&R monitoring.

Recruiter Checklist

Chapter 10: Planning ID&R Deployment and Supporting Recruiters

Did you?

- Consider how best to deploy recruiters on a statewide basis?
- Consider how to support recruiters?
- Consider how to develop programs for mentoring, peer coaching, team building, and peer networking?
- Consider how to evaluate and improve training strategies?
- Decide how and when to assess recruiter performance?
- Understand that employee termination is sometimes necessary?

Chapter 11. Quality Control in the ID&R System

Responsibility for Quality Control

The basic message that quality control should send to recruiters is that someone will check your work.

A core responsibility of each SEA is to ensure that only those children and youth who are truly eligible for the MEP are recruited, counted, and served. Each recruiter plays an important role in helping the SEA get the data it needs to make accurate MEP eligibility decisions and produce an accurate state child count. To that end, the SEA produces an annual Child Count Narrative that explains how the state counts only those children who met the program eligibility criteria and resided in the state for at least one day during the eligible period. Furthermore, the SEA is required to describe how it ensures the quality of all child eligibility determinations. One way this is ensured is through the federally-mandated re-interview process described in 34 C.F.R. § 200.89(b). Meeting this re-interviewing responsibility is key to ensuring that (1) the SEA only provides MEP-funded services to eligible migrant children, (2) the MEP allocation each state receives reflects its statutory share of the MEP funding that Congress appropriates annually for services to migrant children, and (3) public confidence and the integrity of the MEP remains strong. Rigorous quality control should be applied to all components of the ID&R process to ensure accountability and accuracy at every stage.

Everyone who works in ID&R, including the recruiter and the administrator, is responsible for knowing the child eligibility requirements and ensuring quality control. The recruiter's role—which includes conducting comprehensive eligibility interviews, filling out the COE adequately and accurately, and helping to make correct eligibility determinations—is discussed in detail in the previous chapters. The administrator has primary responsibility for ensuring that the quality control system works.

Overview of Quality Control

For the MEP, the key outcome of identification and recruitment activities is a “proper” and “timely” eligibility determination (not a COE).

The basic principles of quality control are widely used in engineering and manufacturing, and are designed to ensure that a high production standard is consistently met by testing the product at several points during the manufacturing process. “Most products are made with a profit in mind, so the main purpose of quality control is to maintain acceptable quality levels at the lowest possible cost.”¹ The MEP has a similar goal, to develop efficient and cost-effective strategies for identifying all eligible migrant children and for making proper and timely MEP eligibility determinations confirmed via routine checks and balances.

¹ *Encyclopædia Britannica Online School Edition*, s.v. “quality control,” accessed July 30, 2012, <http://school.eb.com/eb/article-9276608>.

Basic Principles. For the MEP, the primary focus of the quality control system is to determine whether or not only eligible migrant children are enrolled in the program. When the SEA qualifies an ineligible child or youth for the MEP, a defective eligibility determination has occurred. A strong ID&R quality control system will result in:

- Developing standard procedures that consistently result in correct MEP eligibility decisions
- Developing effective training programs to give recruitment staff the knowledge and skills needed to make correct MEP eligibility decisions
- Inspecting and testing MEP eligibility, particularly in areas where problems are the most likely to occur
- Taking corrective action when problems are found to make sure they do not happen again
- Receiving fewer complaints and maintaining public confidence by making sure that federal dollars are spent on eligible children

The purposes of quality control are to (1) ensure that the SEA's system of identifying children eligible for MEP services is working properly, (2) find children who have been incorrectly determined to be eligible for the MEP, and (3) to identify where problems have occurred and to fix them. When an administrator finds an incorrect eligibility determination, the administrator should determine which part of the ID&R process failed and why. For example, the failure might have occurred because the recruiter did not ask enough questions during the interview, the interview was not translated properly, or the recruiter did not fully understand the eligibility criteria. Once the administrator knows what went wrong, the administrator can use this information to improve the ID&R process by offering better training, meeting with recruiters more frequently, or providing clearer ID&R guidance.

Process-Oriented Quality Control. For purposes of the MEP, there are two kinds of quality control activities: “process-oriented” and “product-oriented.” Process-oriented quality control looks at each action a recruiter takes to determine whether a child is eligible for the MEP, and attempts to pinpoint where errors are the most likely to occur. To explain how process-oriented quality control works, here is an example from the car manufacturing industry. Car manufacturers have inspectors who check each job within the plant to see if that job was done correctly. If a worker forgets to screw in a bolt when installing a headlight, that worker has made a process-oriented error, which may lead to a loose headlight.

To apply this same principle to ID&R, if a recruiter forgets to ask if every child in the family moved when conducting an interview, that recruiter has made a process-oriented error. This may lead to mistakenly enrolling a child in the MEP who is not eligible. Here are some other examples of process-oriented errors in determining child eligibility:

- Not asking enough questions
- Misinterpreting or not understanding some aspect of the law, regulations, or Guidance
- Ignoring facts provided during an interview

- Forgetting to ask the reason why a family moved

However, there are a number of things an administrator can do to reduce the number of process-oriented errors. Here are some examples of process-oriented ID&R quality control activities that will help to reduce process-oriented errors:

- Hiring qualified recruiters
- Providing orientation programs for new recruiters and ongoing training for all recruiters
- Testing the recruiter’s knowledge of child eligibility rules
- Providing tools to help the recruiter make correct eligibility determinations (a supplemental interview form such as the *Sample Interview Script* (see Appendix VIII), and *Basic Child Eligibility Factors Chart* (see Chapter 7)
- Having the new recruiter observe knowledgeable and skillful recruiters conduct interviews with migrant families and youth and receiving guidance and feedback from them (“shadowing” and “coaching”)
- Having the supervisor observe the recruiter as he or she conducts an eligibility interview, particularly during the first months on the job
- Checking with the recruiter on a regular basis to make sure the recruiter is using a systematic, logical and efficient interview process
- Providing opportunities for the recruiter and other recruitment staff to talk about situations they have encountered and discuss whether particular children are eligible for the MEP such as during regular monthly meetings
- Having the recruiter work with others to make final eligibility determinations, particularly in difficult cases (e.g., the administrator, knowledgeable recruiters)
- Developing a recruiter ethics policy (see Appendix VII)
- Providing incentives for reducing errors

Thus, to eliminate or reduce errors which can lead to defective eligibility determinations, administrators and recruiters must understand and accept that: (1) an error or mistake in the recruiting process can lead to an incorrect eligibility determination, (2) the overwhelming majority of errors are human errors, (3) to fix a problem, you must determine the source of the problem and learn from the mistake, and (4) detecting and correcting human errors quickly is critical to reducing the number and costs of incorrect eligibility determinations.

Product-Oriented Quality Control

A “defect” is an imperfection that impairs worth or utility (of any type of product).¹

Product-oriented quality control activities examine the outcome or product to identify defects and suggest improvements. Product-oriented defects are usually identified after the activity or process has taken place—in this case, after the eligibility determination has been made. In the world of the MEP, product-oriented quality control usually refers to re-interviewing practices.

Administrators often ask the best way to discover defects. The answer is to inspect the final product. For example, a car manufacturer may test-drive a car to determine if it has any defects. Similarly, an administrator should arrange to have secondary reviewers check the accuracy of eligibility determinations after they are made. The best way to do this is by re-interviewing migrant families and youth to ensure that proper eligibility determinations were made. Re-interviewing is discussed in greater depth later in the chapter.

Figure 6 illustrates that, while there are costs associated with identifying problems at *any* stage of the ID&R process, these costs can be greatly reduced when errors are prevented or caught early (e.g., extra effort, ineligible children receiving MEP services).

Figure 6. Cost of Defects In Comparison to Time of Defect Detection²

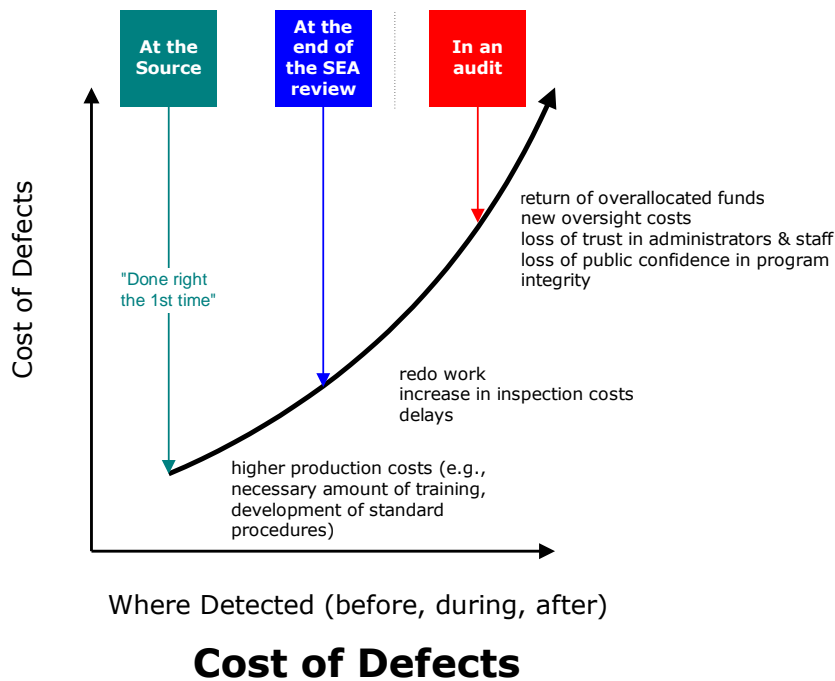

¹ Merriam-Webster, <http://www.merriam-webster.com/dictionary/defect>, accessed July 31, 2012.

² Ghinato, P., 2008. Quality control methods: Towards modern approaches through well established principles, Total Quality Management, 9(6): 463-477.

Detecting errors during the ID&R process can result in re-doing the work and some delays in the ID&R of truly eligible children. However, identifying defective eligibility determinations after the ID&R process has been completed results in even greater costs. Identifying defects after funds have been spent on ineligible children can mean

- (1) returning MEP funds that were allocated based on erroneous data,
- (2) expanding costly oversight and quality control of ID&R processes,
- (3) losing the trust of state and local administrators, OME representatives, other partners, and the general public, and
- (4) experiencing the personal anxieties and troubles associated with audits and their aftermath.

Therefore, administrators should make a concerted effort to catch problems early, when they are easier and less costly to correct. It is always better to perform tasks “right the first time.”

For the reasons discussed in this section, it is essential to inspect both (1) the process used to make child eligibility determinations and (2) the actual product, or the child eligibility determination itself. It is important to make correct eligibility decisions to avoid diverting services from truly eligible and deserving migrant children and incurring the costs of corrective actions that are required as a result of program monitoring or audit.

Quality Control Tools. SEAs may require local projects to implement quality control strategies to ensure the integrity of eligibility information. SEAs and LOAs can use instruments such as the COE checklist and COE flowchart (presented later in this chapter) as they design their own quality control process. SEAs may find the *Sample Interview Script* (see Appendix VIII) useful in developing their own re-interview script, and may also want to read through the quality control process described later in this chapter.

Quality Control in ID&R

I gather all of my recruiters at weekly meetings to discuss the interviews they conducted during the previous week. We talk about the eligibility decisions they have made – both the children that they qualified and the children that they did not qualify. This is a great learning experience for everyone and increases the consistency of our eligibility decisions.

In accordance with the requirements published in 34 CFR § 200.89(b)(2), an SEA must establish minimum requirements for a system of quality controls that an SEA must implement in order to promote accurate migrant child eligibility determinations. Quality control is needed to ensure that only eligible children and youth are identified, recruited and enrolled in the MEP. This is of utmost importance as state and local MEP funding is based on the number of children and youth identified and recruited into the program. The various components of a quality control system are discussed below.

Training the Recruiter. 34 CFR § 200.89(d) of the regulations maintains that training is required to ensure recruiters and all other staff involved in determining eligibility and in conducting quality control procedures know the requirements for accurately determining and documenting child eligibility under the MEP.

Therefore, the first important component of a quality control program is providing high quality training for new recruiters and experienced recruiters alike. As discussed in Chapter 9, the SEA and/or regional offices should train recruiters at least annually on child eligibility requirements and it should be a combination of classroom and field based training, as well as independent study. This training should cover the basic eligibility definitions, as well as issues like purpose of the move, moved for economic necessity, temporary vs. seasonal, processing, etc. Administrators may be able to minimize the number of problems that are identified through re-interviewing by providing effective training (see Chapter 9).

Supervision and Evaluation of Individual Recruiters. 34 CFR § 200.89(d) of the regulations maintains an SEA's system of quality control must include supervision and annual review and evaluation of the identification and recruitment practices of individual recruiters.

As discussed in Chapter 9, it is important to hire recruiters who are self-starters and can work productively on their own. However, supervisory support and the development of a team are both critical for the recruiter to avoid feeling alone or isolated.

Supervisory Support. The administrator should maintain regular contact with the recruiter in the field to dispel any feelings of isolation the recruiter may experience. Many recruiters work out of their homes, drive their cars for most of the day in rural areas, and knock on the doors of people who may not be at home. Many have no officemates and their administrator may be located hours away. Some describe recruitment as a lonely job. It is important for the recruiter to know that someone is interested in and understands the work. Furthermore, the new recruiter, in particular, needs regular feedback on whether he or she is making correct preliminary child eligibility determinations, particularly during the first few months on the job. A Motorola Inc. study showed that new employees were more likely to retain the knowledge and skills they learned during initial training if managers provided coaching and support as the skills were being applied.¹ Therefore, the administrator should continually reinforce the key lessons learned in the basic classroom training.

There are a number of ways the recruitment administrator can stay in regular contact with the recruiter in the field, including:

- Weekly phone calls or Skype
- Emails (personal emails, not group emails)
- Field visits by the administrator or designee who is not part of a monitoring review

¹ Clemmer, Jim. "Why Most Training Fails," [online article], available at <http://www.jimclemmer.com/why-most-training-fails.php>. (November 23, 2011).

The administrator should set aside funding in the budget to spend a certain number of hours in the field with recruiters each month. Regular contact not only helps dispel feelings of isolation, but also helps to build a positive rapport between the recruiter and the administrator. This increases the likelihood that the recruiter will contact the administrator when a question, ethical dilemma, or problem arises.

As part of planning and deploying, the administrator should work with the recruiter to set up a recruitment schedule that uses time wisely. In particular, the administrator should provide the following support to the recruiter:

- An ID&R system which supports school- and field-based recruiting
- Flexible hours to allow for meeting and interviewing when families or youth are available or to attend evening meetings
- Sufficient mileage (consider that recruiters might need to visit several families before they find one who is eligible, and they need enough mileage to visit members of their recruitment network)
- Time to survey/canvass the area before expecting the recruiter to produce COEs
- Time for training or professional development

For accountability purposes, the administrator may ask the recruiter to complete an activity log to account for the recruiter's time.

Performance Assessments. The administrator should regularly observe and provide feedback to the recruiter. New recruiters, in particular, want to do a good job and want to understand what the administrator expects of them. Observing the recruiter helps the administrator understand how the recruiter approaches interviewing migrant families and youth and whether it is likely that the recruiter is making correct eligibility determinations. Observing the new recruiter during the early stages of the work is particularly important so that problems can be corrected early on before they become habits. Providing specific examples of employee behavior makes both praise and constructive feedback more effective.

Performance assessments also offer the administrator a chance to see whether the new recruiter, who is looking at the state and local ID&R systems with "fresh eyes," has suggestions for improving ID&R efforts. Furthermore, assessment meetings provide an opportunity to identify the recruiter's training and development needs to increase the recruiter's productivity. The recruiter should be encouraged to conduct self-evaluations by talking with migrant families, school officials, agricultural employers, and members of the recruiter's network to get ideas on how to be more effective.

Reviewing the COE

We have a COE review and approval team. They look at the COEs that have been returned and develop a report on recurring problems that can be addressed in training.

34 CFR § 200.89(d) of the MEP regulations provides that an SEAs system must have an examination by qualified individuals at the SEA or LOA level of each COE to verify that the written documentation is sufficient and that, based on the recorded data, the child is eligible for MEP services

Reviewing the COE prior to processing is a required early step a state takes to test the validity of eligibility determinations. For many administrators, a primary component of the COE review is reading and reviewing the supplemental interview form along with the more formal COE. The administrator, peer or other designated reviewer should verify that the eligibility data recorded on the COE is consistent with the supplemental interview form and adequate to document the child or youth's eligibility for the MEP. Incomplete or otherwise questionable COEs should be returned to the recruiter for correction, further explanation, better documentation, and/or verification. The MEP regulations require SEAs to have a review process in place that examines the validity of the COE by having all completed COE forms reviewed by at least one additional person before the information is entered into the state's migrant database. Some of the steps that a COE review may cover at different levels include:

- The recruiter reviews the COE with the parent or other interviewee at the time of the interview to make sure that the information recorded on the COE is correct.
- A trained administrator, peer reviewer or other trained staff member checks the COE before the data is entered into the migrant database (some states require both the recruiter and the administrator to be trained and certified by the SEA annually). The reviewer often finds errors related to dates (e.g., transposed numbers), incomplete sections, and eligibility errors (e.g., residency date before the QAD; children born after the move).
- After the initial review, the data entry specialist (DES) checks the COE. A DES can catch even more errors involving numbers. For example, many databases will not allow the information to be entered if it does not make sense (transposed digits in a birth date, for instance). Also, the DES has access to the entire state database, whereas many recruiters and administrators do not. Because the DES has all the student's previous entries they may see a wrong DOB whereas a reviewer would not have known the DOB is wrong.
- The state monitor randomly selects a sample of completed COEs for re-interviewing.

The flowchart in Figure 7 examines the process of completing and reviewing a COE. The COE Review process varies from state to state and can be influenced by factors such as:

- The number of migrant children
- The number of COEs
- The size of a region
- Regional resources
- Available technology

Many states use a reviewer checklist as a tool to help the reviewer ensure that the COE has been completed correctly (see Appendix XII). Having a checklist readily available during an interview makes it easier for the recruiter to conduct frequent self-assessments and participate fully in the COE review process. A COE review checklist looks at items like the following:

- Completeness and accuracy (all blanks are filled out, dates appear correct, required comments are complete, names appear to be spelled correctly, nicknames are not used, etc.).
- Eligibility determination appears valid (all of the eligibility data appear reasonable, the qualifying work is well documented, and comments are clear).

Some states generate reports that list the numbers and types of mistakes that have been found on COEs. The report is sent to the recruiter so the recruiter can see the types of mistakes made most frequently. The recruiter might want to keep a collection of these reports in a portfolio as a reference tool for professional development. Other states discuss mistakes at their weekly or monthly recruiter meetings or during training.

To correct errors found on COEs, the reviewer typically sends the COE back to the recruiter, with a note indicating where the mistake was made and asking for clarification. Even though many mistakes may be simple for the reviewer to correct, it is advantageous to send the COE back to the recruiter for two main reasons:

- *Inaccurate assumptions.* The reviewer may want to correct seemingly erroneous information on a COE such as a misspelled last name or an unusual qualifying activity. However, the information may be correct, even if it is unusual. The reviewer should have the recruiter verify the accuracy of the information rather than assuming it is a mistake.
- *Repeated mistakes.* When the reviewer corrects repeated “simple mistakes” made by a particular recruiter, such as not completing dates or leaving lines blank, the recruiter does not realize that mistakes were made and will not learn to complete the COE properly.

Figure 7. COE Review Flowchart

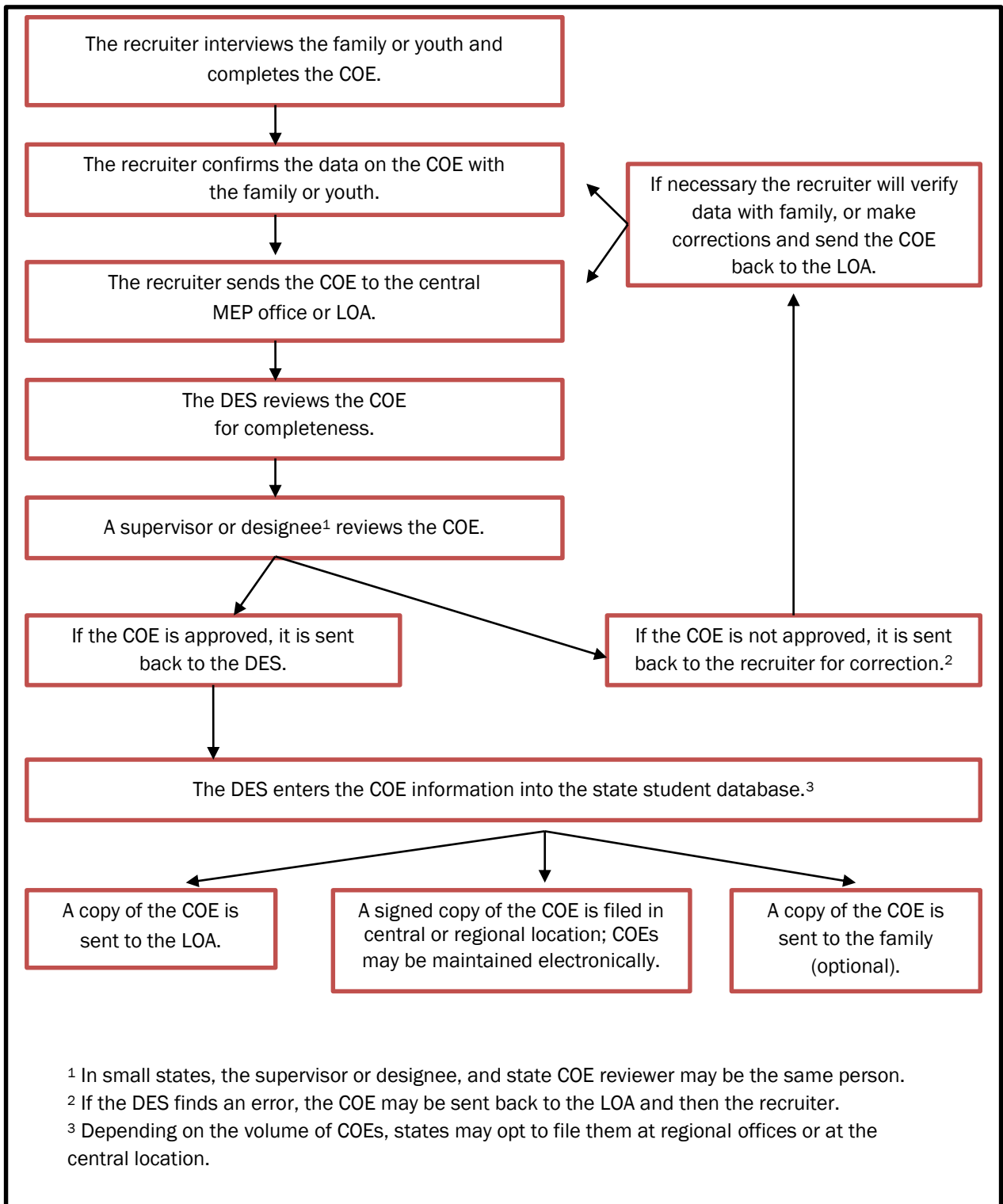

Establishing State Policies. Some aspects of child eligibility are determined by state laws, regulations or policy rather than federal laws or regulations. A prime example of this is the meaning of the term school completion. Under federal law, a migrant child can be served as long as that child is still entitled to a free public education in his or her state (see sections 9101(4) and 9101(21) of the ESEA, and 34 C.F.R. § 200.103(a)(1). However, states have different rules regarding when a child is considered to have completed high school. For example, here are three factors to consider:

1. *Age beyond which a child is no longer entitled to a free public education.* Some states have established an upper age limit for when a child stops being entitled to a free public education. In situations such as these, the LOA must enforce such limits. The state MEP must determine whether there is an age limit on how long children are able to attend school in that state or if it is a local decision. Regardless of the age limit set by the SEA or LOA, the ESEA does not permit students to be considered eligible for the MEP after they have turned 22 years of age.
2. *State requirements for “school completion.”* Each state sets its own requirements for high school diplomas, GED tests, and “Certificates of Completion,” so these requirements vary state to state. Under some state laws, having been awarded a GED, a certificate of completion, a certificate of course completion, or a certificate by any other name does not terminate a person’s right to pursue a high school diploma. In other states, the opposite is true. The SEA must determine whether degrees other than a high school diploma terminate a child’s right to continue to attend high school in that state, and if so, which degrees are considered terminal.
3. *State rules with regard to treatment of degrees from other countries.* States have different rules regarding whether a child who has received a high school diploma or degree in the child’s home country (e.g., the *preparatoria* in Mexico) is eligible to obtain a U.S. high school diploma. The SEA needs to identify which degrees from other countries, if any, would prevent a child from being entitled to receive a free public education in order to attend high school in that state.

Each state MEP must research its own state laws, regulations and/or policies to determine the rules in each of these areas. Based on this research, the state MEP should establish a clear policy on what constitutes school completion and communicate that policy to recruiters.

Resolving Eligibility Questions

34 CFR § 200.89(d) of the regulations maintains that an SEA must have a formal process for resolving eligibility questions raised by recruiters and their supervisors and for ensuring that this information is communicated to all local operating agencies.

Some states have found it useful to form state or regional eligibility policy teams made up of the ID&R coordinator, experienced recruiters, and/or ID&R staff to resolve eligibility questions. When a new policy question is raised, the team leader (generally the ID&R coordinator) investigates to learn whether that question or a similar question has been answered in the Guidance, state ID&R manual,

past correspondence, or by peers in other districts or states. If the question has been answered previously, the answer is sent to the questioner. If it has not been answered previously, the team discusses the question to determine whether they are comfortable answering the question based on the law, regulations, and guidance. If the team cannot come to an agreement, the question is either resolved by the ID&R Coordinator or moved to the next administrative level.

Questions that deal with statutory or regulatory requirements and are broad in scope (i.e., affect the eligibility of many children in the state) should be referred by the state to OME. For questions that are sent to OME, the SEA should provide as much background information as possible, including all relevant facts that would affect the eligibility determination, and the number of children whose eligibility would potentially be affected. The SEA should also provide its analysis of the question and its proposed response.

When the SEA answers a question on its own, or when it receives a response from OME, the SEA must communicate these answers not just to the recruiter or local MEP that asked the question, but to all LOAs to ensure consistent ID&R statewide. The SEA also should keep a log of these questions and responses in a portfolio for later reference and/or for training purposes. For more information on this topic, see the section on *Determining Eligibility in Difficult Cases* in Chapter 7.

Validating Child Eligibility

I pull every 10th new COE and re-interview that family. I tell the family that I'm checking on the quality of our recruitment system and that I will send them a book as a thank you for letting me re-interview them. The Reading Is Fundamental program donates the books. By re-interviewing families right after the COEs come in, I can correct any problems we find immediately. That way recruiters know right away if they are doing something wrong.

34 C.F.R. § 200.89(d) of the MEP regulations provides that an SEA must have a process for the validating that eligibility determinations were properly made, including conducting prospective re-interviewing as described in paragraph (b)(2). They must have documentation that supports the SEA's implementation of this quality-control system and a record of actions taken to improve the system where periodic reviews and evaluations indicate a need to do so. Finally, an SEA must also have a process for implementing corrective action if the SEA finds COEs that do not sufficiently document a child's eligibility for the MEP, or in response to internal state audit findings and recommendations, or ED monitoring or audit findings.

Figure 8. Steps in Validating Child Eligibility

Steps to Validating Child Eligibility
<ol style="list-style-type: none"> 1. Inform administrators about the re-interviewing process. 2. Determine which families will be re-interviewed. 3. Decide who will conduct the re-interview. 4. Develop an interview protocol. 5. Train the interviewer. 6. Interview the family. 7. Determine if each child or youth is eligible for the MEP. 8. Resolve any problems that are identified. 9. Develop a process for recruiters to provide additional evidence, information or documentation. 10. Determine defect rate. 11. Summarize problems and identify their causes. 12. Document the process.

One way that SEAs and districts confirm the quality of eligibility determinations is by annually re-interviewing the families of currently eligible children. This process is referred to as prospective re-interviewing. As stated above, MEP regulations require each the SEA to have a process for re-interviewing a sample of migrant children each year. For a detailed explanation of how to conduct prospective re-interviewing see section III of the *OME Technical Assistance Guide on Re-interviewing*. In general, OME recommends that:

Each recruiter has at least one randomly selected eligibility determination checked each year. The re-interview be conducted shortly after the initial interview as (1) the interviewee will be easier to locate, (2) it will be easier for the interviewee to remember what he or she said in the original interview, and (3) the program can catch and correct mistakes more readily.

The SEA must maintain documentation regarding (1) how the quality control process was implemented, (2) what the findings were, and (3) how they were resolved.

When conducting re-interviews, the SEA may want to consider the following:

1. *Inform administrators about the re-interviewing process.* Each state and/or local MEP administrator should speak with his or her supervisor to ensure that the supervisor understands that migrant families will be re-interviewed and the methodology that will be used. For example, if the MEP is located in the federal programs unit within the SEA, the state MEP director would want to inform the federal programs director. Similarly, local MEP administrators would want to inform appropriate local officials (e.g., school superintendent, principal, federal programs director, regional director). Having clear lines of communication is useful in the event that the re-interview identifies children who are not eligible for the MEP, since further action will be required.
2. *Determine which families will be re-interviewed.* SEAs need to determine how many families will be re-interviewed and develop a process for selecting families (including replacing families who cannot be located or who refuse to be interviewed). SEAs are encouraged to consult with a sampling expert to determine the sample universe, sample timing, and the selection of random sampling method.

SEAs should be careful not to let recruiters or other LOA staff know which families will be re-interviewed to reduce the opportunity to “coach” families who made the list (i.e., suggest how they should respond to re-interview questions). The SEA may wish to notify LOAs that some migrant families will be re-interviewed. However, SEAs should decide whether to provide advance notification to either the families to be visited or to the original recruiter.

3. *Decide who will conduct the re-interview.* SEAs can use their existing recruitment staff as re-interviewers two out of every three years. Every third year, the SEA must hire one or more independent interviewers to conduct the re-interviews (i.e., someone who was not associated with the original eligibility determination; an interviewer who is not employed by the MEP at either the SEA or LOA level). During the non-independent years, SEAs should use staff who are as independent as reasonably possible. At a minimum, the recruiter and reviewer who were involved with the original eligibility determination should not be part of the re-interview. Some examples of individuals who can be used to conduct re-interviews during the non-independent years include recruiters from another region or district in the state, the state ID&R coordinator, and recruiters from another state. Examples of individuals who can be used to conduct independent re-interviewing include retired MEP staff; SEA staff (e.g., audit staff or staff from other programs); staff from the regional laboratories or comprehensive centers; outside consultants; recruiters from other states; temporary recruiters; or staff from other programs that serve migrant children (e.g., Migrant Health, Migrant Head Start). If the individual who conducts the re-interview does not speak the family’s native language, a translator will also be needed.

States may want to have MEP staff introduce the re-interviewer to the parent. This can be done through a reminder note or advance phone call. The interviewer can also reassure families by explaining that the purpose of the re-interview is to check on interviewers or to determine whether the state’s ID&R training works as desired. Interviewers should be honest with families and clearly inform them that they might lose services because of their answers

and let them know that there is an appeals process. This process is more likely to be understood by families as quality control measures become institutionalized. A good way that states can be proactive about re-interviewing is to let families know upon recruitment that they might be asked to participate in a second interview.

SEAs should be on the lookout for recruiters who have engaged in fraud (i.e., have made intentional errors) or have coached families on how to respond. The purpose of re-interviewing is to verify child eligibility determinations. If problems are discovered, they must be addressed.

4. *Develop an interview protocol.* The interview protocol includes determining how migrant families will be contacted, what they will be asked, and how the re-interviewer will document the answers. The SEA may modify a supplemental interview form (see Appendix VIII), as explained in Chapter 6, for the purposes of re-interviewing. The interviewer should ask *open-ended* questions similar to those below and supplement them with additional probes that help get at whether the family moved to obtain temporary or seasonal work in agriculture or fishing due to economic necessity. The interviewer should NOT ask leading questions or ask the family member to simply confirm information that is recorded on a COE. The OME *Technical Assistance Guide on Re-interviewing* includes several tools and examples to assist with prospective re-interviewing.
5. *Train the interviewer.* The interviewer needs to be trained on the interview protocol and the MEP eligibility requirements. A number of states have formed eligibility teams that are made up of knowledgeable staff who can discuss difficult eligibility cases and determine whether the child or youth is eligible for the MEP (see additional information below).
6. *Interview the family or youth.* Interviews should be conducted at a time that is convenient for the family or youth. This may mean conducting the interview during evening and weekend hours or during breaks in the family's workday. The re-interview can be conducted at the home, the workplace, the school, or any other mutually agreeable location.
7. *Determine if each child or youth is eligible for the MEP.* After the re-interview is completed, but before leaving the family, the interviewer is encouraged to compare the information on the original COE to the information provided during the re-interview. If discrepancies exist, the interviewer may probe further with the family, being careful to continue to use open-ended questions and not to divulge eligibility information provided previously (in some cases, workers may be reluctant to admit to having qualifying employment because they were paid in cash and did not file taxes or because they do not have a valid work permit). After all of the interviews have been completed, eligibility determinations that are not clear can be discussed and resolved by the state eligibility policy team using a process like the one described in the section entitled *Resolving Eligibility Questions* found earlier in this chapter. During the year that the SEAhires independent interviewers to carry out the process, eligibility determinations that are not clear can be brought to an independent person or group.

8. *Resolve any problems that are identified.* If there are mistakes on the original COE that do not affect the child's eligibility, the mistakes should be corrected or a new COE should be completed. Some SEAs make changes to the hard copy of the COE in red ink so the change is clearly visible and it is clear that the change was made during the re-interview. Most SEAs require all revisions to be initialed and dated. The information must also be corrected in the state's migrant database.

If a child is found to be ineligible, the SEA must do the following:

1. Stop serving the child immediately.
2. Remove the child from the state child count (leave the child in the migrant student database, but change the child's code to "inactive" or "ineligible").
3. Inform the family that the child is not eligible for the MEP.

Furthermore, the SEA should contact OME to determine if any further steps are necessary (e.g., return funds to the state's MEP account if MEP funds were used to serve non-eligible children). Cases of fraud must be reported to the OIG.

If a particular recruiter has made errors, the SEA should investigate additional eligibility determinations made by that recruiter. Repetitive errors may indicate that additional training is needed or may indicate fraud on the recruiter's part. In either case, the SEA should be prepared to make use of the appropriate remedy.

9. *Develop a process for recruiters to provide additional evidence, information or documentation.* SEAs should develop a process whereby the recruiter can provide additional evidence, information or documentation to support an eligibility determination that has been questioned (e.g., pay stubs, employment records). Based on this additional information, the state can review both the original eligibility determination and the determination from the re-interview to make a final determination.
10. *Understand the difference between a defect vs. a discrepancy rate.* OME uses different terms to describe the percent of ineligible children found during retrospective vs. prospective re-interviewing. The term *defect rate* is used for retrospective re-interviewing, and the term *discrepancy rate* for prospective re-interviewing. In conducting retrospective re-interviews and calculating a *defect rate*, an SEA must construct its sample size so that it achieves a minimum confidence level of 95 percent and a confidence interval no larger than plus or minus 5 percent. See 34 CFR § 200.89(b)(1)(iii) and (b)(2)(ii) and OME's *Technical Assistance Guide on Re-Interviewing* at page 57. In conducting prospective re-interviews and calculating a *discrepancy rate*, an SEA must test a sufficient number of randomly selected eligibility determinations on a statewide basis or within categories associated with identified risk factors to help identify possible problems with the State's eligibility determinations; note, however, that when calculating a "discrepancy rate" for prospective re-interviewing it is not necessary to meet the minimum requirements for confidence level and confidence interval that apply when calculating a "defect rate." See OME's *Technical Assistance Guide on Re-Interviewing* at page 3. The following example can be applied to the calculation of both

defect and discrepancy rates using the correct samples size for the particular re-interviewing method used. For example, if an SEA looked at 100 eligibility determinations as part of the re-interview process, and eight of the children were found to be ineligible, the defect or discrepancy rate would be 8% (8 divided by 100). If only one child from a family was selected as part of the re-interviewing sample, but all of the children in the family were reviewed and determined to be ineligible, the SEA should remove all of the ineligible children from the child count. However, only the child who was selected as part of the re-interviewing sample should be included in the calculation of the defect or discrepancy rate.

11. *Summarize problems and identify their causes.* Children can incorrectly be qualified for the MEP because of fraud (i.e., intentional error), mistakes in interpreting eligibility rules, or simple misunderstandings of the family’s history. OME does not consider minor errors in the documentation of an otherwise eligible migrant child or youth (such as an imprecise QAD recorded on a COE) to be a defective eligibility determination. Still, SEAs should correct common documentation errors and address them in recruiter and administrator trainings. On the other hand, errors that affect eligibility should definitely be recorded and the reason that the error was made should be identified. Furthermore, SEAs need to develop a corrective action plan to address problems in making proper eligibility determinations that these errors highlight.
12. *Document the process.* SEAs must maintain documentation of the re-interviewing process (e.g., sampling frame, selection and replacement procedures, the sample of children, instructions and materials given to interviewers, meeting notes, re-interview notes, problems identified, corrective actions, etc.). OME may ask to examine documentation of a state’s quality control process during a monitoring review.

Monitoring Eligibility

The purpose of monitoring is to verify that currently enrolled children are eligible to receive MEP services. SEAs may use state staff or independently hired consultants to monitor and review eligibility determinations. Also, states and local MEPs may conduct “peer reviews” to assess their ID&R activities (performed by peer reviewers/experienced recruiters, often from other regions). By conducting peer reviews, state and local MEPs may determine if their ID&R plans and other efforts are being implemented properly.

In addition, LOAs can contribute to quality control by monitoring their own ID&R efforts using the same procedures and instruments employed at the state level. The accountability and quality control of programs can be improved by periodically scheduling state and local monitoring reviews. The scheduling of regular peer reviews and monitoring visits helps recruitment staff become less apprehensive and intimidated by more formal state or federally mandated reviews.

After a review, the state can ask the LOA to provide the following information as a record of the monitoring visit:

- Completed monitoring instruments

- Copies or lists of reviewed COEs
- Results from re-interviewing families.
- Copies of other reviewed forms
- Copies of correspondence between the SEA and the LOA regarding the review, including any actions taken.

In monitoring, SEAs usually select the number of COEs to be reviewed based on the total number of children currently enrolled in the district. If the SEA does not have a pre-established acceptable defect rate from the more formal retrospective re-interview initiative, OME considers a reasonable statewide random sample to be about 50. Since it may be impossible to review all of the documentation in certain situations (i.e., large states or regions), SEAs should randomly select the COEs to be reviewed for monitoring purposes.

Report Fraud or Misconduct. The administrator should provide recruiters with the state's policy for reporting fraud or misconduct. If the administrator suspects fraud, waste or abuse involving ED funds or programs, the administrator should call or write to the OIG Hotline using any of the following methods:

- Call the OIG Hotline's toll free number 1-800-MIS-USED. The Hotline's operating hours are from 9:00 a.m. until 4:00 p.m. Eastern Time, Monday through Friday, except for holidays.
- Send an email message to oig.hotline@ed.gov.
- Complete and submit an electronic complaint form, which is available on ED's website at: <http://www2.ed.gov/about/offices/list/ocr/complaintintro.html>.
- To ensure complete anonymity, download a hard copy of the complaint form, complete, and mail to: Inspector General's Hotline; Office of Inspector General; U.S. Department of Education; 400 Maryland Avenue, SW; Washington, D.C. 20202-1510.

As mentioned previously, fraud is a crime; intentional falsification should be taken seriously by everyone and should be reported immediately.

Evaluating and Improving. The SEA should have a process for implementing recruiter recommendations and corrective actions in response to the re-interviewing process, the evaluation results, and internal monitoring findings. SEAs should use the results of their quality control system to determine where improvements are needed; and develop an action plan for implementing those improvements. Areas where improvements are often needed include improved training and greater oversight of recruiters, particularly new recruiters.

Recordkeeping. As with any federally funded program, the MEP requires a high degree of accountability and recordkeeping. The child's record of eligibility, identified needs and the services provided should be documented and maintained either electronically or in a paper file. Since the

MEP serves children and families who cross school district and state boundaries frequently, these records should be available in case they need to be exchanged among programs.

- *What Records to Keep.* Some records (such as the COE) are kept because they document the child's eligibility for the MEP, while other records are kept to satisfy state needs or requirements (such as past and present action plans, manuals and training materials). For example, some states require the recruiter to maintain logs that document the amount of time spent on recruitment activities. For staff who are split-funded or have other responsibilities, the SEA must ensure that, consistent with cost principles contained in US Office of Management and Budget Circular A-87 the amount of time spent on recruitment matches the percentage of the person's salary that is supported by the MEP. SEAs may also require mileage logs to support mileage reimbursement. Moreover, states may keep client services reports, educational assessment results, and other documentation that MEP services were provided.
- *Where to Keep Records.* Each SEA should have clear procedures for updating, filing, storing, and securing COEs. Larger states, for example, are likely to have their COEs stored at regional service centers, rather than at the SEA MEP office. Smaller states, on the other hand, might have all their COEs stored at the SEA office because the volume of COEs is more manageable. Each SEA should devise a system that is efficient, accurate, affordable, and readily available for any audit or monitoring review. With the increase of scanning technology and electronic COEs, storing and filing documents has become easier for the MEP. In addition, electronic signatures for recruiters and reviewers may now be an option.
- *How Long to Keep Records.* Generally, records must be maintained for three years after the date the grantee or local operating agency submits its last expenditure report for the period in question. (See section 80.42(b) and (c) of EDGAR; 34 C.F.R. § section 80.42(b) and (c).) If any litigation, claim, negotiation, audit, or other action involving the records has commenced before the expiration of the three-year period, the records must be retained until completion of the action and resolution of all issues that arise from it, or until the end of the regular three-year period, whichever is later.

Based on the three-year period, the length of time that an SEA must keep a COE depends on whether the child makes subsequent qualifying moves, which will increase the amount of time. For example, a certificate of eligibility that indicates that a child made a qualifying move in October 2012 means that the child will remain eligible, without another qualifying move, until October 2015. A child eligible in October 2015 would be included in the Category 1 child count for the period September 1, 2015 – August 31, 2016 and would generate FY 2017 funding for the state. FY 2017 funds may be used, with carryover, until September 30, 2019. The SEA does not need to submit the final expenditure report for these funds to ED until as late as December 31, 2019. *The three-year record retention period begins in December 2014 when the SEA submits the final expenditure report and runs until December 31, 2019. Therefore, the SEA would have to keep this particular certificate of eligibility until December 31, 2022* (See MEP draft *Guidance*, Chapter XI, Question C3.)

The COE is the primary means of documenting a child's eligibility for MEP services. For this reason, the SEA should take particular care to keep COE data safe, secure, and readily accessible.

Conclusion

Quality control and monitoring are tools that will keep an ID&R system in good working order. The administrator responsible for ID&R, either at the state or local level, will make decisions about how much time and effort to invest in the task. Those who ignore or minimize their efforts do so at their own risk and at the program's peril. SEAs must have a well-defined quality control process that trains recruiters, examines the validity of COEs, and re-interviews families to test underlying eligibility determinations. Having rigorous and effective quality control procedures will protect the integrity of the program and ensure that only eligible migrant children benefit from the MEP.

Recruiter Checklist

Chapter 11: Quality Control in the ID&R System

Did you?

- Establish a quality control system?
- Establish a process for re-interviewing selected migrant children (families) each year?
- Establish a process for reviewing COEs, ensuring at least one second party reviews the COE prior to certification?
- Establish a process for resolving eligibility questions?
- Develop procedures and standards for keeping records?

This page left blank intentionally.

Appendices

Appendix I: Legal Issues

The Elementary and Secondary Education Act of 1965 (ESEA), as amended by the No Child Left Behind (NCLB) Act of 2001, is the principal source of law that MEP recruiters and administrators will need to know. However, as recruiters do their work and get to know migrant families, the family situations they will learn about may raise questions about whether migrant children or their families have rights or benefits available to them under other laws. The purpose of this Appendix is to help recruiters and administrators gain some familiarity with some of the other laws that may be relevant, and provide them resources where they may learn more.

Reporting Responsibilities

On occasion, home visitors, recruiters and other MEP staff discover situations that are troubling, may violate state or local law, or may even endanger the lives of migrant children. For example, the recruiter may encounter cases (or suspected cases) of child abuse or neglect, or suspicion of criminal activity that may, depending on the state and the situation, require the recruiter to report information to law enforcement authorities and/or social service agencies.

Child Abuse and Neglect. There is no federal law on reporting suspected cases of child abuse or neglect (at the time this manual was published). However, in order to protect children most states have laws requiring school personnel and others to report suspected cases of child abuse or neglect. According to the Children's Bureau, an office within the U.S. Department of Health and Human Services was established to provide access to information and resources to help protect children and strengthen families. States designate individuals, typically by professional group, who are mandated by law to report child maltreatment.

While any person may report incidents of abuse or neglect, individuals typically designated as mandatory reporters have frequent contact with children and include:

- Health care workers
- School personnel
- Child care providers
- Social workers
- Law enforcement officers
- Mental health professionals

Some states also mandate that animal control officers, veterinarians, commercial film or photograph processors, substance abuse counselors, and firefighters report abuse or neglect. For a state-by-state comparison of reporting requirements or other state-specific information (reporting telephone numbers, services) contact the Childhelp®, at 1-800-4-A-CHILD (800-422-4453, toll-free) or visit: http://www.childwelfare.gov/systemwide/laws_policies/state/ on the Child Welfare Information Gateway's website: <http://www.childwelfare.gov/>. (It is possible that individual localities may have their own additional reporting requirements.)

Typically, when one has reasons to suspect that a child has been abused or neglected one must report this to the proper authorities. All recruiters and other migrant education staff need to ensure that their supervisors provide them with the requirements for reporting suspected child abuse or neglect in their states and localities. While migrant recruiters and home visitors and others may feel that reporting certain situations may hinder their effectiveness and affect their duties, they should remember that if they are required by law to report suspected child abuse or neglect they must do so.

Truancy. A school-age student who is absent from school without permission is a “truant.” Although the precise definition may vary from state to state, in most states, except for situations such as excused absences, home schooling, etc., it is against the law for anyone between certain ages not to attend school (typically between the ages of six and 16).

Here again, federal law does not address issues of truancy. State or local law may, and many schools and districts have “truancy officers” who have the authority and responsibility to “ticket” students who are not in school and report them and their parents to the authorities, and in some cases to child welfare agencies. Migrant recruiters in some states may feel pressured to cooperate with truancy officers by reporting migrant school-age students who miss school; however, state and local migrant programs should provide guidance regarding how to handle cases of truancy, and what legal responsibilities, if any, recruiters and other staff working with migrant children and their families have in this area.

Parental Consent

At times, school personnel may want or need to exchange information about specific migrant children with other service providers. For example, they may wish to provide relevant records to other school districts that enroll these students, provide a full-range of services to migrant children, or otherwise work with other agencies to help make program decisions. Federal law, specifically the Family Educational Rights Privacy Act of 1974 (FERPA), governs how and when a school district may provide these records to others. (Individual states may also have their own requirements.)

FERPA is a federal law that applies to educational agencies and institutions that receive funding under a program administered by the U. S. Department of Education. (Parochial and private schools at the elementary school level do not generally receive such funding and, therefore, are not subject to FERPA.) Under FERPA, schools must generally afford parents: access to their children's education records, an opportunity to seek to have the records amended, and some control over the disclosure of information from the records.

Parents may access, seek to amend, or consent to disclosures of their children's education records, unless there is a court order or other legal document specifically stating otherwise. When a student turns 18 years of age or attends a postsecondary institution, the student, and not the parent, may access, seek to amend, and consent to disclosures of his or her education records

Access to Education Records

Schools are required by FERPA to:

- Provide a parent with an opportunity to inspect and review his or her child's education records within 45 days of the receipt of a request
- Provide a parent with copies of education records or otherwise make the records available to the parent if the parent, for instance, lives outside of commuting distance of the school
- Redact the names and other personally identifiable information about other students that may be included in the child's education records

Schools are not required by FERPA to:

- Create or maintain education records
- Provide parents with calendars, notices, or other information which does not generally contain information directly related to the student
- Respond to questions about the student

Amendment of Education Records

Under FERPA, a school must:

- Consider a request from a parent to amend inaccurate or misleading information in the child's education records
- Offer the parent a hearing on the matter if it decides not to amend the records in accordance with the request
- Offer the parent a right to place a statement to be kept and disclosed with the record if, as a result of the hearing, the school still decides not to amend the record

A school is not required to consider requests for amendment under FERPA that seek to change (1) a grade or disciplinary decision, (2) the opinions or reflections of a school official or other person reflected in an education record, or (3) a determination with respect to a child's status under special education programs.

Disclosure of Education Records

A school must generally have a parent's consent prior to the disclosure of education records and ensure that the consent is signed and dated and states the purpose of the disclosure. However, FERPA permits a school or other educational agency to disclose education records without consent in certain circumstances, such as when:

- The disclosure is to school officials, including teachers, of the LEA in which the student is currently enrolled who have been determined to have legitimate educational interests as set forth in the school district's annual notification of rights to parents (see below)
- The disclosure is to another LEA or institution of higher education in which a student seeks or intends to enroll, or is already enrolled and, consistent with specific provisions in FERPA governing these actions, either (1) the disclosure is consistent with , the school district's annual notification of its intent to provide records to such an educational agency or institution and rights of parents to inspect these records and, upon request a right to a hearing or (2) the district tried to first notify the parent of the proposed transfer.

The school also may disclose these records without parental consent if (1) the disclosure is to state or local educational authorities auditing or evaluating federal or state supported education programs or enforcing federal laws which relate to those programs, (2) the disclosure is pursuant to a lawfully issued court order or subpoena, (3) the information disclosed has been appropriately designated by the school as “directory information.” Directory information includes a student's name, address, telephone number, date and place of birth, honors and awards, and dates of attendance. However, schools must tell parents and eligible students about directory information and allow parents and eligible students a reasonable amount of time to request that the school not disclose directory information about them.

Thus, regardless of the assistance that other agencies may be able to provide to migrant children and their families, FERPA requires a school or district to obtain parental consent before it provides a child’s educational records (including a child’s COE) to social service and community agencies or to institutions of higher education that might be interested in recruiting or serving migrant children, but at which the student has not enrolled or is not seeking to enroll.

.

Annual Notification

A school must annually notify parents of students in attendance that they must allow parents to:

- Inspect and review their children's education records
- Seek amendment of inaccurate or misleading information in their children's education records
- Consent to most disclosures of personally identifiable information from education records

The annual notice must also include:

- Information for a parent to file a complaint of an alleged violation with the Department’s Family Policy Compliance Office
- A description of who is considered to be a school official and what is considered to be a legitimate educational interest so that information may be shared with that person
- Information about who to contact to seek access or amendment of education records

Schools may provide this notification through a local or student newspaper, calendar, student programs guide, rules handbook, or other means reasonable likely to inform parents. The notification does not have to be made individually to parents.

Complaints of alleged violations of FERPA may be addressed to:

Family Policy Compliance Office
U.S. Department of Education
400 Maryland Avenue, SW
Washington, DC 20202-5901

More information regarding FERPA may be obtained on the website of the Family Policy Compliance Office at: <http://www2.ed.gov/policy/gen/guid/fpco/index.html>.

Access to Services

There are many legal rights and safeguards that promote a student's rights to access educational services. These include the following:

School Attendance Regardless of Civil Status (Plyler vs. Doe). The U.S. Supreme Court ruled 5-4 in the case of *Plyler vs. Doe*, 457 U.S. 202 (1982) that the State of Texas could not deny to undocumented immigrant students a free public education that other students enjoy (i.e., the Court ruled that these undocumented children have the same right to a free, public education as U.S. citizens and permanent residents). Faced with minor children who had entered the United States from Mexico illegally with their parents, the Supreme Court concluded that while Congress had the authority to act on issues involving the Nation's immigration laws, it had not done so with regard to the eligibility of undocumented students to attend school. In the absence of any clear Congressional policy to the contrary, the Court therefore found that the Constitutional protections of due process and equal protection demanded that these children not be penalized because of the actions of their parents. As a result of this decision, public schools and school personnel are prohibited from adopting policies or taking actions that would deny such minor students access to education based on their immigration status. (The decision does not affect the right of school district officials to require adequate evidence that any student—including immigrant students— resides within the area that the school district serves.)

A Note on Social Security Numbers. The Social Security Administration is responsible for administering and performing the duties regarding Social Security Numbers (SSN). Most of the guidance regarding a school district's release of a student's SSN concerns FERPA.

Generally, state laws or state constitutions require school districts to provide a free public education to all children who reside in the area the districts serve. Hence, possession of a social security number should not be a factor that affects any child's right to a free public education.

Meaningful Opportunity for Limited-English Proficient Students to Participate in School Programs (Civil Rights Act of 1964). In *Lau vs. Nichols* (1973), the U.S. Supreme Court ruled unanimously that the San Francisco school system violated Title VI of the Civil Rights Act of 1964 (20 U.S.C. 2000d) by denying non-English speaking students of Chinese ancestry a meaningful opportunity to participate in their public educational program. Title VI prohibits discrimination based on race, color, or national origin. The Court affirmed a memorandum of the former U.S. Office of Education that, on the basis of

Title VI, had directed school districts to take steps to help limited-English proficient students overcome language barriers and to ensure that they can participate meaningfully in the district's educational programs.

The Court found that simply providing students the same desks, books, teachers, and curriculum as other students did not ensure that these students received an equal educational opportunity since students who do not understand English are effectively foreclosed from any meaningful education. Where English is the principal language of instruction, the decision also means that the district must provide these students with a meaningful opportunity to learn English as part of their school program. Moreover, because this right stems from the Civil Rights Act of 1964, school districts must use state or local funds, rather than MEP or other federal program funds, to meet their responsibilities for providing such meaningful opportunity to participate in school programs.

The U.S. Department's Office of Civil Rights (OCR) has interpreted the Civil Rights Act of 1964 to apply to "national origin minority students" who are learning English as a second language, or whose ability to learn English has been substantially diminished through lack of exposure to the language. OCR conducts investigations of the educational services provided for language minority students either as a result of a complaint allegation or through a compliance review. For more information on the rights of Limited-English Proficient (LEP) students, see the website of the Department's Office of Civil Rights at: <http://www2.ed.gov/about/offices/list/ocr/qa-ell.html>. Information on how to file a complaint may be found at: <http://www2.ed.gov/about/offices/list/ocr/docs/howto.html>.

(NOTE: The Equal Educational Opportunity Act of 1974 (20 U.S.C. 1703) similarly prohibits states from denying equal educational opportunity to an individual on account of his or her race, color, sex, national origin, or by the failure of an educational agency to take appropriate action to overcome language barriers that impede equal participation by its students in its instructional programs. However, violations of this statute are enforced through the U.S. Department of Justice.)

Section 504 of the Rehabilitation Act of 1973. Section 504 of the Rehabilitation Act of 1973 prohibits discrimination (including employment discrimination) based on disability in programs or activities receiving federal financial assistance, including the funding that the U.S. Department of Education provides to schools, school districts, and other local educational agencies. Examples of the types of discrimination prohibited include access to educational programs and facilities, denial of a free appropriate public education for elementary and secondary students, and academic adjustments in higher education.

ED's regulations governing Section 504 are in Part 104 of the Code of Federal Regulations. Among other things, section 104.35 of these regulations provides that a recipient that operates a public elementary or secondary education program shall conduct an evaluation of any person who, because of a disability, needs or is believed to need special education or related services before taking any action with respect to the initial placement of the person in a regular or special education program. The Department's Office for Civil Rights (OCR) investigates claims that Section 504 is being violated, and in appropriate circumstances brings actions for enforcement.

More information on OCR and its mission and activities may be found on OCR's website:
<http://www2.ed.gov/about/offices/list/ocr/index.html>.

School Lunch and Breakfast Programs. The National School Lunch Program (NSLP) is a federally assisted meal program operating in more than 101,000 public and non-profit private schools and residential childcare institutions. It provides nutritionally balanced, low-cost, or free lunches to more than 31 million children each school day. More information about the NSLP is available on the website of the U.S. Department of Agriculture's (USDA's) Food and Nutrition Service at: <http://www.fns.usda.gov/cnd/Lunch/default.htm>). Similarly, the School Breakfast Program (SBP) provides assistance to states to operate non-profit breakfast programs in schools and residential childcare institutions. The program operates in more than 88,000 schools and institutions, serving some 11.6 million children.

While eligibility for free or subsidized lunches and breakfasts depends on family income, Congress in 2004 made migrant children automatically eligible for free school lunches and breakfasts once the LEA (where the school food programs are to be provided) has received documentation of their status as migrant children (as defined in section 1309 of ESEA). On August 16, 2004, the USDA issued a memorandum on the eligibility of migrant children for free lunches and breakfasts. A copy of the memorandum can be found at: http://www.fns.usda.gov/cnd/governance/Reauthorization_Policy_04/Reauthorization_04/2004-08-16.pdf.

Communication with U.S. Citizenship & Immigration Services (USCIS formerly INS) Through the Student and Exchange Visitor Information System. The USCIS operates the web-based "Student and Exchange Visitor Information System" (SEVIS) that, among other things, explains visa requirements and provides other information related to foreign or exchange students who come to attend U.S. schools. See <http://j1visa.state.gov/sponsors/current/sevis/>. SEVIS implements a 1996 federal law that requires the Department of Homeland Security (DHS) to collect current information, on an ongoing basis, from DHS-certified schools and Department of State (DoS)-designated exchange visitor program sponsors relating to nonimmigrant foreign students (F- and M- visas) and exchange visitors (J-visa) during the course of their stay in the United States.

While SEVIS focuses primarily on the requirements governing enrollment in postsecondary institutions, it also provides information on K-12 student-exchange programs and, of particular interest to the MEP, basic information on the F-, M-, and J- visas. SEVIS provides information only with respect to students, including migrant students, who enter the nation legally, i.e., under one of the available visa categories. However, most migrant students will not be in the SEVIS system. J-1 visa status is for high school students who are participating in DoS-designated exchange visitor programs. F-1 visa status is available only for foreign high school students as part of a USCIS-administered student exchange program, and is available for no more than 12 months, and requires reimbursement to the district of the full-unsubsidized cost of education for the period of study. M-1 visa status is for students who attend vocational or other nonacademic programs other than language training, and so, at the K-12 level, typically will be available only to foreign students wishing to attend a vocational high school. Presently, no foreign exchange students may legally enter the U.S. without having first been entered into the SEVIS system by either their sponsoring student foreign

exchange program (J-1 visa holders) or their hosting high school (F-1 visa holders). Moreover, because students with these visas must have made prior arrangements with the school district that will enroll them, no student with one of these visas should be showing up unannounced at a school or school district door.

For information on students who do not have one of these visas, see the discussion above on School Attendance Regardless of Civil Status (*Plyler vs. Doe*).

Welfare Reform Law. In 1996, the Welfare Reform Law was enacted, creating new requirements affecting access by aliens to federally funded programs. The legislation (the Personal Responsibility and Work Opportunity Reconciliation Act, P.L. 104-193), imposed major restrictions on benefits for noncitizens (Haskins, 2009).¹ Certain of the law's provisions may sometimes create tension for school staff, other providers, and the migrant education community. For example, section 434 of the law states:

Notwithstanding any other provision of federal, state, or local law, no state or local government entity may be prohibited, or in any way restricted, from sending to or receiving from the Immigration and Naturalization Service² information regarding the immigration status, lawful or unlawful, of an alien in the United States. Welfare Reform Act, 110 Statute 2275: Sec. 434. Communication Between State and Local Government Agencies and the Immigration and Naturalization Service

The 1996 law substantially changed the circumstances under which non-citizens may receive most federal benefits. For example, although the rules are complex, the most pertinent provision provided that non-citizens who arrived in the United States after 1996 are subject to a five-year ban on most welfare benefits. One exception was that non-citizens may receive emergency services. At the end of five years, non-citizens can receive Temporary Assistance for Needy Families (TANF), Medicaid, and a few other benefits at the discretion of the state in which they reside. Although TANF became effective July 1, 1997, it was reauthorized in February 2006 under the Deficit Reduction Act of 2005. This ban continues on Supplemental Nutrition Assistance Program (SNAP), historically and commonly known as the Food Stamp Program (if over 19 years and not pregnant, see next section below) and the Supplemental Security Income (SSI) program until the immigrant works for 10 years or becomes an American citizen. Some immigrants who entered the U.S. before 1996 continue to be eligible for Supplemental Security Income and SNAP.

<http://georgewbush-whitehouse.archives.gov/news/releases/2002/02/welfare-book-10.html>.

Children's Health Insurance Program Reauthorization Act of 2009. When Congress reauthorized the State Children's Health Program or SCHIP, states became eligible to provide Medicaid and CHIP coverage to children and pregnant women (up to age 19 for CHIP or up to age 21 for Medicaid) who are lawfully residing in the United States, including those within their first five years of having certain

¹http://www.brookings.edu/~media/research/files/papers/2009/12/18%20welfare%20reform%20haskins/1218_welfare_reform_haskins (December 2009)

² In 2003, the functions of the U.S. Immigration and Naturalization Service were transferred to the new Department of Homeland Security.

legal status. This bill was the repeal of the previous, federal law (the Welfare Reform Law of 1996) which required the five-year waiting period before many legal immigrants could enroll in Medicaid and CHIP. For more information, visit <http://www.medicaid.gov/Medicaid-CHIP-Program-Information/By-Topics/Childrens-Health-Insurance-Program-CHIP/CHIPRA.html> or <https://www.cms.gov/chipra/>.

Eligibility of migrant students and families for welfare programs depends upon whether a state has elected to provide these benefits to “qualified aliens.” This is affected by whether the applicant meets the definition of “qualified alien” and in some cases whether the individual entered the country prior to August 22, 1996 or has been in “qualified alien” status for five years. If a state provides TANF, Medicaid or SCHIP benefits to “qualified aliens,” then an otherwise eligible individual who meets the definition of “qualified alien” and who entered before August 22, 1996 or who has been in a “qualified alien” status for five years should be eligible. It should be noted that while certain immigrants are not eligible for federally funded benefits, such as TANF, SNAP, Medicaid or SCHIP because of their immigration status, in some cases states may elect to provide state-funded benefits including income maintenance, nutrition assistance, or health care. For guidance on the most recent policies effecting immigrant children and families go to: <http://www.hhs.gov/ocr/civilrights/resources/specialtopics/origin/policyguidanceregardinginquiriesntocitizenshipimmigrationstatus.html>.

Social Security Numbers (SSNs) are required of all TANF and Medicaid applicants and recipients. However, SSNs are required only for the persons for whom Medicaid benefits are actually sought (e.g., a mother can apply for Medicaid benefits for her children without seeking benefits for herself, in which case she is not required to provide her SSN, but she is required to provide SSNs for her children). If a non-citizen, who is not eligible for regular Medicaid, qualifies for emergency Medicaid coverage, the applicant cannot be required to provide a SSN. SSNs are not required for the stand-alone, separate SCHIP; however, they are required for the Medicaid expansion SCHIP. The TANF rules regarding who is an “applicant” may vary from state to state, but generally families are required to apply for benefits as a unit. For more information, visit <http://www.hhs.gov/ocr/civilrights/resources/specialtopics/origin/policyguidanceregardinginquiriesntocitizenshipimmigrationstatus.html>.

Appendix II: Resources and Partnerships

As discussed in Chapter 4, recruiters often find locating migrant children and their families to be the most time-consuming and labor intensive of their duties. To find migrant children efficiently and effectively, the recruiter should start by determining which local people and organizations are known and trusted within the migrant community. These are the recruiter's best sources of information and referrals.

In determining which organizations are the most productive for the recruiter to network with, the recruiter should answer the following questions:

- Which organizations serve migrant farmworkers?
- Which stores and businesses cater to migrant farmworkers?
- Which organizations in the community speak the same language as local farmworkers?
- Which organizations provide outreach services to migrant farmworkers? For example, these organizations could include the outreach workers at the One-Stop Career Centers, National Farmworker Jobs Training Grantees, and Migrant Head Start programs. In addition, recruiters might want to contact the Migrant Health Program, Farmworker Legal Services, and local religious and community-based organizations.
- Who knows where migrant farmworkers live? Does the farmer provide housing? A good starting place is to ask outreach workers from the local, state, and federal partner agencies listed below.
- Who inspects migrant labor housing? Each state has one or more entities that are charged with inspecting migrant labor housing. In some states, this is done by the State Department of Health. In other states this is done by the Department of Agriculture. Contact the State Monitor Advocate in your state to determine who conducts these inspections and if a list of the licensed labor camps in the state has been compiled. However, be aware that many farmworkers live in commercial housing that is not regulated or inspected.

The following are some organizations that collect information about or serve migrant families. Building a recruiting network with organizations like the following is an important part of a recruiter's job:

U.S. Department of Education (ED): <http://www.ed.gov>

1. **College Assistance Migrant Program (CAMP).** This program assists migrant and seasonal farmworkers and their immediate family members to successfully complete the first undergraduate year of study in a college or university, and provides follow-up services to help students continue in postsecondary education.
<http://www2.ed.gov/programs/camp/index.html>.

2. **High School Equivalency Program (HEP).** This program assists migrant and seasonal farmworkers and their immediate family members who are 16 years of age or older to obtain a General Education Development (GED) certificate or the equivalent to a high school diploma and subsequently to gain employment in a career position, the military or entry into postsecondary education. Since most HEP programs are located at institutions of higher education (IHEs), migrant and seasonal farmworkers also have opportunities to attend cultural events, academic programs, and other educational and cultural activities usually not available to them. <http://www2.ed.gov/programs/hep/index.html>.
3. **Migrant Student Records Exchange Initiative.** This initiative assists states in developing effective methods to ensure the linkage of state migrant student information systems and in determining the number of migratory children in each state. The primary mission is to ensure the appropriate enrollment, placement, and accrual of credits for migrant children. [The Migrant Student Information Exchange \(MSIX\)](http://www2.ed.gov/programs/msix/) is the technology that allows states to share educational and health information on migrant children who travel from state to state and who, as a result, have student records in multiple states' information systems. MSIX works in concert with the existing migrant student information systems that states currently use to manage their migrant data to fulfill their mission to ensure the appropriate enrollment, placement, and accrual of credits for migrant children nationwide. <http://www2.ed.gov/admins/lead/account/recordstransfer.html>.
4. **Binational Migrant Education Initiative (BMEI).** The MEP, in concert with the Mexican government, has developed and promoted a Binational Migrant Education Initiative to improve the continuity and support of educational opportunities for migrant children who shuttle between both countries. The program has numerous components, including:
 - a. *Teacher Exchange Program* – Teachers from Mexico come to the U.S. to work for local MEP programs, usually during the summer. Also, teachers from the U.S. visit schools and towns in Mexico to learn about the Mexican educational system, curriculum, and culture.
 - b. *Transfer of Student Records* – In order for binational students to be promoted and accrue credits, students' records need to be shared and interpreted in a timely and efficient manner between the two countries. The BMEI helps states and local MEPs in this effort.
 - c. *Free Textbooks from Mexico* – This is a free resource for MEPs and helps Mexican migrant students continue their Spanish language development in various content areas.

Additional efforts on behalf of binational migrant children are being conducted in many states. For more information, contact the Center for Migrant Education, Southwest Texas State University, 601 University Drive, San Marcos, TX 78666, 512-245-1365, 866-245-1365 (toll free) or <http://www2.ed.gov/admins/tchrqual/learn/binational.html>.

U.S. Department of Labor (DOL): <http://www.dol.gov>

The DOL administers programs that are important resources for migrant farmworkers and their families and collects statistical information that can be useful in finding farmworkers and understanding their needs. The Employment and Training Administration (ETA) of the DOL serves the American farmworker population through the following programs:

1. **National Farmworker Jobs Program (NFJP).** The NFJP, which is authorized by Section 167 of the Workforce Investment Act, provides job training and employment assistance for legally residing migrant and other seasonally employed farmworkers and their families. Services may be obtained through the DOL's local One-Stop Career Centers. The NFJP program is administered by community-based grantee organizations. Each grantee has one or more outreach workers. For more information, visit the NFJP website at <http://www.doleta.gov/msfw/> and <http://www.doleta.gov/msfw/html/facts.cfm>. The NFJP program directory is available online at <http://www.doleta.gov/msfw/pdf/GranteeDirectory.pdf>.
2. **NFJP Housing Assistance.** Funding is provided through a competition to community-based organizations to ensure that support for housing is provided to eligible migrant and seasonal farmworkers, giving priority to those who have the greatest need for housing assistance. Housing assistance includes direct payments for emergency and temporary housing and for direct investments in housing assistance for migrant and seasonal farmworkers at their home base. Indirect assistance includes leveraging services to increase or maintain housing available to farmworkers and housing development designed to improve living conditions for underserved farmworker communities. For more information and a list of grantees, visit the NFJP housing assistance website at <http://www.doleta.gov/msfw/html/housing.cfm>.
3. **State Workforce Agencies.** Each State Workforce Agency has a Monitor Advocate whose job is to ensure that domestic migrant and seasonal farmworkers receive equitable access to One-Stop Career Center services include training, assessment, and job referral. Among other things, Monitor Advocates (1) participate in planning and operating DOL's One-Stop Career Centers; (2) develop linkages with a broad range of stakeholders, including community- and employer-based organizations; (3) provide information on farmworker needs, characteristics, and concerns; and (4) ensure that all legal protections are afforded to farmworkers and that their complaints are resolved promptly. For more information and the National Monitor Advocate Directory, visit the Employment and Training website at <http://www.doleta.gov/programs/msfw.cfm>. Each State Workforce Agency also has one or more outreach workers stationed throughout the state in the One-Stop Career Centers.

4. **Temporary or Seasonal Agricultural Work Certification Program (H-2A).** The temporary agricultural program allows employers to hire temporary or seasonal foreign workers when there is a shortage of U.S. workers who are able, willing, qualified, and available. Certification that applicable conditions have been met is required before a foreign worker can be brought to the U.S. on an employment-based visa. More information on the H-2A program is available online at <http://www.foreignlaborcert.doleta.gov/h-2a.cfm>.

Employers are required to submit a complete labor certification application to the appropriate national processing center and local state workforce administration at least forty-five (45) calendar days before the first date on which workers are needed. There are two national processing centers, one in Atlanta, and the other in Chicago (contact information for the two sites are available under “contact us” online at <http://www.foreignlaborcert.doleta.gov/h-2a.cfm#>). Many of the workers who come to the U.S. as part of the H-2A program are age 22 or over. Of those who are below the age of 22, recruiters should be aware that they may have come to the U.S. for the sole purpose of working and therefore may not be interested in receiving educational services (Under the H-2A program, visas are issued to individuals for less than one year. Moreover, H-2A workers are not permitted to bring their families).

5. **National Agricultural Workers Survey (NAWS).** The NAWS collects information on household and family composition, demographics, employment history, wages, benefits, working conditions, health, safety, housing, income, assets, social services, and legal status. The survey samples all crop farmworkers in three cycles each year to capture the seasonality of the work. The NAWS is available online at <http://www.doleta.gov/agworker/naws.cfm>.
6. **Migrant and Seasonal Agricultural Workers Protection Act Program.** Works to ensure that those who hire, employ, furnish, transport, or house migrant and seasonal farmworkers comply with the requirements of the Fair Labor Standards Act and the Migrant and Seasonal Agricultural Workers Protection Act. For more information, visit <http://www.dol.gov/compliance/laws/comp-msawpa.htm> and <http://www.dol.gov/compliance/guide/mspa.htm>.

U.S. Department of Agriculture (USDA): <http://www.usda.gov>

USDA directly touches the lives of millions of families every day through a wide-range of programs. USDA (1) collects and maintains information on U.S. agricultural products; (2) leads the federal anti-hunger effort with the Supplemental Nutrition Assistance Program (SNAP), historically and commonly known as the Food Stamp Program (FSP), child nutrition programs, the Women Infants and Children Program (WIC); and (3) brings housing, modern telecommunications, and safe drinking water to rural America.

1. **Supplemental Nutrition Assistance Program (SNAP).** The SNAP is a nutrition assistance program that provides crucial support to low income households to enable them to buy the food they need for good health. Participants receive a monthly allotment of benefits via an electronic benefit card, similar to a bank card, which is used to purchase food at authorized retail stores and farmer’s markets. SNAP benefits supplement the food

budget of low-income individuals and families and enable them to purchase more healthy foods like fruits, vegetables, and whole grains. Communities benefit from the economic impact of food stamp redemption in local stores.

A pre-screening tool or “calculator” is available online at <http://www.snap-step1.usda.gov/fns>. The tool, available in English and Spanish, provides users with an estimate of eligibility and an estimate of the amount of benefits they could receive. Migrant families may apply for SNAP by contacting the local SNAP office. In some states, online applications are available. More information about SNAP benefits is available in English and Spanish by calling 1-800-221-5689 or by visiting <http://www.fns.usda.gov/fns/sp-default.htm>. For information about non-citizen eligibility requirements check out http://www.fns.usda.gov/snap/government/pdf/Non-Citizen_Guidance_063011.pdf.

2. **Child Nutrition Programs.** These programs help children and some adults get the nutrition and nutrition education they need to be healthy and develop healthy eating habits, at school or as part of their day care. For example, the National School Lunch Program (NSLP) provides nutritious lunches and snacks for free and reduced prices to low-income children while they are in school, in after-school care, or in summer school. Migrant children are automatically eligible for free school lunches and breakfasts once documentation of their status as migrant children has been provided to the LEA (where the school food program services are to be provided). When area schools are closed, the Summer Food Service Program provides free meals to children at parks, recreation centers, and other community sites. The Child and Adult Care Food Program serves children who are enrolled in child care, attending after-school care programs, or residing in emergency shelters. More child nutrition information is available online at <http://www.fns.usda.gov/cnd/>.
3. **Special Supplemental Nutrition Program for Women, Infants, and Children (WIC).** The WIC Program is a public health nutrition program providing nutritious supplemental foods, nutrition education, and health care referrals to low-income, nutritionally at-risk pregnant, breastfeeding, and non-breastfeeding postpartum women, infants, and children up to age 5. Program policies ensure that WIC services are focused on the needs of the migrant population and ensure program access and services to them. WIC services are administered by state health departments and offered at community and migrant health centers. For more information, go to <http://www.fns.usda.gov/wic/>.
4. **Census of Agriculture.** The Census of Agriculture is the leading source of statistics about the Nation's agricultural production and is the most comprehensive source of agricultural data available at the county level. USDA's National Agricultural Statistics Service conducts the census of U.S. farms and ranches every five years. There are approximately two million farms in the U.S. and according to the 2002 census 40,848 farms hired migrant farm labor and 6,536 farms reported migrant contract labor. The Census of Agriculture provides estimates of hired farm labor at the national, state, and county level. The Census of Agriculture is available online at http://www.nass.usda.gov/Census_of_Agriculture/index.asp.

5. **The National Institute of Food and Agriculture (NIFA) is the former Cooperative State Research, Education, and Extension Service.** The mission of NIFA is to advance knowledge of agriculture, the environment, human health and well-being, and communities by supporting research, education, and extension programs in the Land-Grant University System and other partner organizations. Each U.S. state and territory has a state office at its land-grant university and a network of local or regional offices. These offices are staffed by experts who provide useful, practical, and research-based information to agricultural producers, small business owners, youth, consumers, and others in rural areas and communities of all sizes. The county extension service agent can be a good source of information on local agricultural activities. For more information, go to <http://www.csrees.usda.gov/>. To find the closest Cooperative Extension Service office, go to <http://www.csrees.usda.gov/Extension/index.html>.

Department of Health and Human Services (DHHS): <http://www.hhs.gov>

1. **Migrant Health Program.** The Migrant Health program provides grants to community-based non-profit organizations to offer a broad array of culturally and linguistically competent medical and support services to migrant and seasonal farmworkers and their families, including both primary and preventative health care. The Health Resources and Services Administration (HRSA) administers this program. More information is available online at <http://bphc.hrsa.gov/about/specialpopulations/index.html>.
2. **Migrant and Seasonal Head Start Program.** This program provides a comprehensive early childhood program for migrant and seasonal preschool children, from birth to compulsory school age. It offers education, health, nutrition, social, and transportation services. The federal Migrant and Seasonal Program Branch administers this program through local organizations. To search for the closest Head Start program, go to <http://eclkc.ohs.acf.hhs.gov/hslc/HeadStartOffices>. To see all of the Head Start programs, go to <http://eclkc.ohs.acf.hhs.gov/hslc/About%20Head%20Start>. Information on the Migrant and Seasonal Head Start Quality Improvement Centers is available online at <http://www.mhsqic.org/>.
3. **The Center for Medicaid and CHIP Services (CMCS).** The Medicaid program helps people who can't afford to pay for medical care get the care they need. Medicaid, which provides direct payments to health care providers, is only available to low-income individuals and families who fit into an eligibility group recognized by federal and state law. Medicaid is a state administered program and each state sets its own guidelines regarding eligibility and services. Some states require individuals to pay a small part of the cost (co-payment) for some medical services. For more information, go to <http://www.medicaid.gov/index.html>.

Land-Grant Colleges and Cooperative Extension Agencies

Land-grant colleges and cooperative extension programs are administered through the USDA: <http://www.csrees.usda.gov/qlinks/extension.html>. Some services MEP staff may find of use include:

1. Field representatives, commonly known as “county agents,” with established networks of growers and farmers
2. Network information in relation to harvests, forecasts, weather, and the latest cropping techniques
3. Information on harvesting trends, use of labor, and mechanization of crops

Cooperative extension programs provide information on a variety of farm-related issues through county extension agents who visit local farms and through key contacts at land-grant colleges and universities. Agriculture faculty at these institutions often can provide valuable insights on changing harvesting trends, use of labor, mechanization of crops, and the human and political implications of these changes.

Occupational Safety and Health Administration (OSHA): <http://www.osha.gov>

1. Training for farmworkers in issues such as safety and pesticides
2. Assistance to growers using the guest worker programs
3. Regulations on migrant housing
4. Lists of migrant housing and camps

Census Bureau: <http://www.census.gov>

1. Information on demographic changes
2. Projections on population changes by state, region, county, and city

School Districts

1. Lists of new enrollments
2. Enrollment dates

Maintaining rapport and good communication with the district is important since, most often, they will be the principal providers of services to the children.

Appendix III: Sample Surveys

Migrant Education Workplace Survey	
Date: _____	
Please return this form to: _____	
1. Name of Company or Farm:	
2. Name of Grower or Supervisor:	
3. Name and Position/Title of Contact Person:	
4. Address of Workplace:	
5. Telephone Number of Workplace:	
6. Directions to Workplace:	
7. Do you hire seasonal or temporary employees? If yes, how many?	
8. What type of work do they do?	
9. When does the work typically start (approximate date)?	
10. When does the work typically end (approximate date)?	
11. Do you provide housing? If so, where?	
12. Is there anything that we should know about the workers (e.g., primary language in case translation is needed)?	
Comments:	

Adapted from the Nebraska Manual for Identification and Recruitment.

Migrant Education Employee Survey	
Date: _____	
Please return this form to: _____	
1. Is anyone in your household under the age of 22 (including you, your spouse, your child)?	<input type="checkbox"/> Yes <input type="checkbox"/> No
2. Have you moved to a new town to find work within the last 3 years?	<input type="checkbox"/> Yes <input type="checkbox"/> No
3. Did you find work in agriculture or fishing (e.g., field work, processing plants, nurseries, dairy work)?	<input type="checkbox"/> Yes <input type="checkbox"/> No
<i>If you answered "yes" to some or all of the questions above, an education representative may contact you to find out whether your child is eligible for additional educational services. Please provide the following information.</i>	
Name:	
Address:	
Telephone Number:	

Migrant Education School Survey

Date: _____

Please return this form to: _____

1. Have you moved to a new town to find work within the last 3 years?

 Yes No2. Did you find work in **agriculture or fishing** (e.g., field work, canneries, lumbering, dairy work)? Yes No

If you answered "yes" to some or all of the questions above, an education representative may contact you to find out whether your child is eligible for additional educational services. Please provide the following information.

Name:

Address:

Telephone Number:

Appendix IV: Sample Brochures

This page left blank intentionally

Programs and services that may be available to your family

- Parent involvement activities
- English language classes
- Preschool programs
- Tutoring
- Summer education programs (reading, mathematics, etc.)
- After school programs
- High school credit for graduation
- High School Equivalency Program
- College Assistance Migrant Program
- Scholarship information
- Help with school supplies
- Career education and awareness
- Emergency health services
- Medical/dental assistance
- Referral services to other local agencies

Please contact us for more information!

[Insert contact information here.]

Title I, Part C Migrant Education Program

Information for Migrant Parents



Help YOUR child succeed in school!

Migrant Children and Education

For your children, moving from harvest to harvest means changing schools and teachers, missing days at school, and feeling like they don't belong. These changes can put your children at greater risk of doing poorly in school. Special services and help are available to migrant children to help overcome these problems to ensure a fair chance at education.

What is the Migrant Education Program?

The Migrant Education Program (MEP) provides extra support to migrant children for their education as required by federal law. The goal is to help migrant students succeed in school, to graduate with a high school diploma (or complete a GED), and to develop skills so that they can find good jobs. It also helps schools respond to the influx of these mobile students.

Is my child eligible for services?

You and/or your children may be eligible to receive free educational or support services if:

- You have moved to a new state or new school district at any time in the last three years in order to seek work with crops, dairy products, livestock, poultry, plants, trees, or fishing, and
- You and/or your children are younger than 22 years of age.

Why is my help needed?

We know that it is very important for parents to be involved in their children's education. Parents are their child's first teachers. The MEP is ready to support you in helping your child learn and grow. Your involvement will show your children how important learning is for life.

Think your child is eligible?

If you think you or your child may be eligible, please call the MEP staff listed on the back of this brochure. A MEP recruiter will be happy to visit with you to talk about whether you and your children can receive services. Not all children are eligible to receive services but it is important for you to call to find out more information. This call may help you and your children get the help they need to succeed in school. Contacting your local MEP will not only help you, it may help other families in the migrant community by bringing services to your area. The MEP can only help those eligible children that it can find. Please contact us today.

Please contact your local MEP listed on the back of this brochure.

Programs and services that may be available to your employees and their children

- English language classes
- Assistance with Parent Involvement in Education
- Preschool Programs
- Tutoring
- Summer Education Programs (reading, mathematics, etc.)
- After School Programs
- High School Credit
- High School Equivalency Program (HEP)
- College Assistance Migrant Program (CAMP)
- Scholarship Information
- Help with School Supplies
- Career Education and Awareness
- Emergency Health Services
- Medical/Dental Assistance
- Referral Services to Other Agencies

Who is Eligible for the MEP?

Migrant workers and/or their children may be eligible to receive free educational or support services if:

- They have moved across state or school districts' boundaries at any time in the last three years in order to seek work in crops, dairy products, fishing, livestock, poultry, trees, or plants, and
- They are younger than 22 years of age.

Not all children are eligible to receive services. But, we can provide helpful services to those who are eligible.

Please contact us for more information

[Insert Contact Information Here.]

Title I, Part C Migrant Education Program

What Employers Should Know about the Migrant Education Program



Educational Services for Migrant Children

The children of migrant farmworkers, who harvest our nation's crops to help feed America, often face great obstacles in pursuit of education. Migration for these children means changing schools and teachers, missing school days, enrolling late or withdrawing early, and feeling isolated. These challenges put migrant children at risk of academic failure. This brochure explains how you as an employer of migrant families can help migrant children to receive a fair chance at education.

What is the Migrant Education Program?

The Migrant Education Program (MEP) provides extra support to migrant children for their education as required by federal law. The goal is to help migrant students succeed in school, to graduate with a high school diploma (or complete a GED), and to develop skills so that they can find good jobs. It also helps schools respond to the influx of these mobile students.

How do employers benefit from the MEP?

Workers whose children are enrolled in good school programs are:

- More likely to stay in their jobs, which reduces costs associated with employee turnover.
- Able to entrust their children to the care of educators and less likely to bring them to the workplace, reducing the risk of liability for employers.
- Better able to concentrate on their jobs and therefore are more productive since they are less worried about their children.

How can I help?

The MEP can only help those eligible children that it can find. You can help bring vital services to your community in important ways.

Contact your local MEP to become part of the recruiting network. When the MEP becomes aware of workers with children in the area, a recruiter visits with the family to determine whether the children are eligible for service.

Allow recruiters to interview workers at your work site. Timely interviews can help ensure that children receive services quickly, with minimal disruption in their school participation. These interviews can be conducted in a way that does not disrupt work.

Please contact your local MEP listed on the back of this brochure.

Programas y servicios que pueden estar disponibles para su familia

- Actividades que envuelven a los padres
- Clases del idioma inglés
- Programas pre-escolares
- Tutoría
- Programas de educación de verano (lectura, matemáticas, etc.)
- Programas después de escuela
- Créditos de bachillerato para graduación
- Programa de equivalencias de bachillerato
- Programa de asistencia de migración de escuela
- Información de becas
- Ayuda con suministros de escuela
- Educación de carrera y concientización
- Asistencia médica/dental
- Servicios de referidos a otras agencias locales

¡Por favor contáctenos para recibir más información!

[Inserte la información de contacto aquí.]

Título I, Parte C Programa de Educación de Migrantes

Información de Migración
para Padres



¡Ayuda a TU hijo a tener éxito en la escuela!

Niños Migrantes y Educación

Para tus hijos, el ir de cosecha a cosecha significa cambiar de escuelas y maestros, perder días de clase y sentirse que no pertenecen. Estos cambios ponen a tu hijo bajo un alto riesgo de no desempeñarse bien en la escuela. Servicios especiales y ayuda están disponibles para los niños migrantes para que puedan superar estos problemas y asegurar una oportunidad justa en su educación.

¿Cuál es el programa de Migración para Estudiantes?

El programa de educación de migración (MEP por sus siglas en inglés) suministra ayuda extra a niños migrantes para su educación, como se requiere por ley federal. La meta es ayudar a los estudiantes migrantes a tener éxito en la escuela, graduarse con un diploma de bachiller (o completar GED) y desarrollar habilidades para que puedan encontrar buenos trabajos. También ayuda a las escuelas con este flujo de estudiantes móviles.

¿Califica mi hijo para los servicios?

Usted y/o sus hijos pueden calificar para recibir servicios de ayuda o educacionales gratis si:

- Se ha mudado a un nuevo estado o distrito escolar en cualquier momento en los últimos tres años
- Busca trabajo con siembras, productos lácteos, ganado, aves, plantas, árboles o pesca y
- Usted y/o sus hijos son menores de 22 años de edad.

¿Porqué se necesita mi ayuda?

Sabemos que es muy importante que los padres se envuelvan en la educación de sus hijos. Los padres son los maestros primarios de los niños. MEP está listo para apoyarlo a usted y su hijo a aprender y crecer. Su involucramiento le mostrará a su hijo lo importante que es aprender.

¿Piensa que su hijo califica?

Si piensa que su hijo califica, llame al personal de MEP enlistado atrás de este folleto. Un reclutador MEP lo visitará para hablar si su hijo puede recibir estos servicios o no. No todos los niños califican para recibir servicios pero es importante que llame para más información. Esta llamada le pueda ayudar a usted y su hijo para obtener la ayuda que necesitan para tener éxito en la escuela. Al contactar su MEP local no solo recibirá ayuda pero puede ayudar a otras familias migrantes trayendo servicios al área. El MEP solo puede ayudar a los niños que puede encontrar. Por favor contáctenos ahora.

Por favor contacte su MEP local de la lista atrás de este folleto.

Appendix V: Sample Letters

To Employers

[School District Letterhead]

[Insert date; e.g., August 15, 2012]

[Insert employer's name and address]

SUBJECT: Migrant Education Program Services for Your Employees

I am writing to you on behalf of the [name of district] Migrant Education Program (MEP) because we believe that some of your employees and their children may be eligible for additional educational services through the MEP. In general, the MEP serves children who are below age 22 and who have moved with a parent, spouse, guardian or on their own to find temporary or seasonal employment in agriculture or fishing. In this district, some of the services that the MEP provides include [name services].

Helping the MEP find and enroll migrant children helps you as an employer because migrant workers whose children are enrolled in good school programs are often more productive and less likely to leave their jobs unexpectedly if they have fewer concerns about their children's well-being. We are pleased to send you the enclosed brochure to introduce our program, explain the benefits for you and your migrant employees, and provide contact information for staff in this district.

We have also enclosed an *Employer Survey* form to help us determine whether any of your employees or members of their family are likely to be eligible for the MEP. **Please take a moment to complete the survey and return it in the enclosed envelope.** If some of your employees or their family members may be eligible, a MEP recruiter will contact you to get more information. Before a child or youth may receive services, an interview has to be conducted with a parent or other responsible adult to ensure that the child qualifies for the program. The program will only use the information that you provide to determine eligibility for the MEP and to provide services. The MEP will not use it for any other purpose. Immigration status is not a criterion for MEP eligibility and we do not collect information on or report the immigration status of MEP participants.

Thank you for your assistance and support of our community's migrant students. You are welcome to contact our offices to learn more about MEP services and how we can partner with you in supporting migrant families. And thank you for taking the time to complete the enclosed survey.

Sincerely,

John Doe
Director
[Name of district] Migrant Education Program

Enclosures

To School Administrators

[SEA Letterhead]

[Insert date; e.g., August 15, 2012]

[Insert administrator's name and address]

SUBJECT: Identification and Recruitment of Migrant Students

The Migrant Education Program (MEP) is a federal education program designed to ensure that all migrant students reach challenging academic standards and graduate with a high school diploma (or complete a GED). Each state MEP is required by federal law to identify and recruit eligible migrant child who reside in that state. We believe that your district might have children who are eligible for additional educational services through the MEP. Districts that have a sufficiently large migrant child population may be eligible to receive funding to provide supplemental educational services to these children.

In general, the MEP serves children who are below age 22 and who have moved with a parent, spouse, guardian or on their own to find temporary or seasonal employment in agriculture or fishing. We are pleased to send you the enclosed brochure, which provides a basic explanation of the program.

If you think your district might have children who are eligible for this program, please contact my office at: [provide contact information]. A MEP recruiter will contact you to get more information and to talk about including the enclosed Migrant Education School Survey form in your school registration packet. The Migrant Education School Survey form is used to help determine whether any children in your district or members of their family are likely to be eligible for the MEP. Before a child or youth may receive services, a MEP recruiter will conduct an interview to ensure that the child qualifies for the program.

It is important to make additional services available to migrant children since they are at greater risk for academic failure than other children due to their migratory lifestyle. Migrant children face educational disruption and disconnection as a result of moving across state and school district boundaries, and enrolling late and/or withdrawing early due to agricultural seasons. Our state education agency is committed to accurately identifying and recruiting eligible migrant children for services in order to help them succeed in school, graduate, and develop employment skills. We are also committed to helping you and your staff manage influxes of migrant students by providing supplemental education and health services, transferring student records, and coordinating with migrant parents about their child's education.

Thank you for your assistance and support of migrant children. You are welcome to contact our office to learn more about MEP services and how we can partner with you in supporting migrant families. If you would like more information about the MEP, please feel free to contact [name] by telephone at [telephone number] or by e-mail at [e-mail address].

Sincerely,

John Doe
Director
[Name] Migrant Education Program
Enclosures

Appendix VI: Sample Individual Action Plan

Individual Recruiter Action Plan

Activity	Timeline
Training and Professional Development	
Complete basic training and study the Guidance to learn who is eligible for the MEP.	Within 2 weeks of employment
Review the common characteristics of migrant agricultural workers and fishers.	Within 2 weeks of employment
Memorize the Basic Migrant Child Eligibility Factors.	Within 2 weeks of employment
Become familiar with the Sample Interview Script (see Appendix VIII) and COE.	On-going
Observe another recruiter in the field.	Within 2 weeks of employment
Prepare an introduction to the MEP for migrant families or youth and a way to “connect” with them.	Within 2 months of employment
Review state ethics policy.	On-going
Review the recruiter’s role in quality control.	Within 2 weeks of employment
Begin conducting MEP interviews.	Within 2 months of employment
Look for opportunities for more training: <ul style="list-style-type: none"> • Attend all local recruiter meetings • Attend regional or state recruiter trainings • Attend national conferences 	On-going
Keep abreast of new educational and reporting laws (i.e., FERPA).	Annually
Research	
Identify local organizations and individuals who work most closely with the migrant community.	Monthly
Review existing profiles of key local employers, school staff, community organizations, and migrant families and develop new profiles as identified.	Monthly
Create a recruitment map that shows areas where migrant families are likely to live and work, services they use, and where their children go to school.	Monthly, On-going
Compare the recruiting calendar with the school calendar.	Annually
Find out how and when local employers do their hiring.	Seasonally
Make personal safety provisions.	Seasonally
Activity	Timeline
Refresh research.	On-going, Annually

Activity	Timeline
Network	
Update contact information on recruitment network.	On-going
Follow up regularly with key contacts, particularly when they provide leads on local migrant families.	Weekly
Participate in health, job, and community fairs.	Annually
Follow up with employers and others in recruitment network through phone calls.	Weekly
Follow up with school to check on new students.	Monthly
Check to see if employers are including MEP materials in new employee packets.	Monthly
Solicit feedback form from employer.	Seasonally
Attend community organization meetings.	Monthly
Send “icebreaker” and “thank you” letters.	Seasonally
Prepare	
Check recruiter tool kit for completeness.	Weekly
Check safety tool kit for completeness.	Weekly
Prepare and replenish “welcome kits” for families.	Weekly
Recruit	
Work with schools, community organizations, etc. to see if they will include pre-screening questions for the MEP as part of their enrollment or intake process.	Annually
Canvass areas where concentrations of migrant children and their families are likely to be found (e.g., migrant labor camps, major local employers).	Seasonally
Visit ESL/GED classes.	Monthly
Inform families whether their children are eligible.	Monthly
Follow up on referrals.	Weekly
Schedule recruitment visits and interviews.	Weekly
Promote the MEP through community outreach using public media.	Monthly, Quarterly

Activity	Timeline
Plan	
Review and update Individual Action Plan.	Seasonally
Meet with supervisor to plan ID&R activities.	Weekly
Review recruitment objectives.	Monthly
Design and print promotional material.	Seasonally
Plan promotional announcements: radio and television announcements and print advertisements.	Seasonally
Document	
Verify that COEs have been submitted and are being reviewed and entered into the state data system.	Daily
File COEs.	Weekly
File other paperwork.	Weekly
Complete recruiter log.	Daily
Support	
Meet with mentor.	Monthly
Share difficult cases with supervisor, mentor or other recruiters.	On-going, Weekly
Attend graduation to support migrant youth and appreciate how recruiters contribute to student success.	Annually
Discuss with colleagues how personal emotions can come into play when dealing with needy families.	Monthly
Take vacation.	Annually
Attend recruiters meeting.	Monthly, Annually
Evaluate	
Evaluate your performance as compared to basic duties and responsibilities.	Annually
Review any changes to the state's organization.	Annually
Arrange to be observed by a supervisor.	Annually
Review your written descriptions of difficult eligibility determinations.	Monthly
Check your COEs for accuracy.	Monthly
Review any COE errors or denied student cases with supervisor.	Annually
Review quality control results from prospective re-interview process.	Annually

Appendix VII: Sample Recruiter Ethics Guidelines

Migrant Education Recruiter Standard of Ethics

The recruiter's primary responsibility is to properly identify and recruit migrant children for the Migrant Education Program (MEP). In carrying out this work, every recruiter is expected to make a commitment to ethical professional behavior. This ethics policy explains what this commitment means.

Recruiters work with migrant farm workers and their families, who are often highly mobile, experience educational disruptions, encounter cultural and language barriers, live in poverty and rural isolation, and have health-related problems that inhibit their ability to do well in school. This policy is intended to serve as a basis for ethical decision-making in the conduct of identification and recruitment (ID&R, 2012, p.129).

Migrant Education Recruiter Standards of Conduct

- ✓ *Know the eligibility rules.* The recruiter should study and prepare to make proper eligibility determinations. The recruiter is expected to have up-to-date knowledge of the eligibility rules established at both the federal and state level.
- ✓ *Be objective.* Recruiters are expected to put aside personal beliefs and biases when making eligibility determinations and to base all decisions on objective facts. Gender, race, religion or age should have no bearing on a recruiter's decisions. Other factors, including whether a particular child "deserves" assistance, should not be considered.
- ✓ *Be honest.* The recruiter's job is to gather information, provide clear documentation on the COE, and help make the eligibility determination. Recruiters must not exaggerate, falsify or omit information. Falsification of program documents may deprive eligible migrant children of needed services, and is against the law and could result in criminal prosecution. Honest recruiters keep the MEP safe so that eligible migrant children will continue to receive educational services.
- ✓ *Report fraud.* It's the recruiter's job to protect the reputation and integrity of the MEP. If the recruiter feels pressured to enroll a child who doesn't appear to be eligible or observes others who are being pressured or who are committing fraud, it is the recruiter's responsibility to report what he or she has observed.

Identify Fraud, Falsification or Misconduct

The dictionary defines fraud as, “intentional perversion of truth in order to induce another to part with something of value or to surrender a legal right” or “an act of deceiving or misrepresenting.”¹ It defines falsify as “to represent falsely” or “misrepresent.”² It may be difficult to understand how these terms apply to the ID&R of migrant children, particularly since it may not seem that any particular person is being deceived. In the case of fraud, intentional falsification or misconduct in ID&R, it is the federal government that is being deceived. Ultimately, when there is fraud, intentional falsification or misconduct in ID&R, the public at large, who pay taxes in the belief that federal funds are being spent as authorized by Congress, is being deceived, as is the federal government, which awards state funding on the assumption that state child counts are accurate. Furthermore, counting children who are not eligible for the MEP can affect the size of subgrants within each state and can dilute services to eligible migrant children. This is why it is important to preserve the public trust by rooting out fraud, intentional falsification, and misconduct in ID&R.

Although it is not possible to provide a complete guide of how fraud or misconduct would look in ID&R, here are some examples of possible fraud or misconduct:

- A supervisor tells a recruiter that the recruiter needs to give the supervisor 40 new COEs by the next week, even though it is impossible to find that many eligible children and interview their families in that amount of time.
- A recruiter picks out a family in need each year and enrolls their children in the MEP so they can get extra services, even though the recruiter knows they don't qualify.
- A data entry specialist points out missing information on a recruiter's COEs; the recruiter disappears for a few minutes and then returns with the information filled out. The data entry specialist thinks the recruiter made up the information since the recruiter couldn't possibly contact the family in that short amount of time.
- A supervisor announces that any recruiter who finds 5% more children than he or she found the previous year will get an expense paid trip to the OME Annual Conference.
- A local recruiting agency qualifies children whose parents supposedly moved to find work picking blueberries. However, none of the workers ever actually seem to get jobs in agriculture. Most, if not all, of the families find work in construction or other non-qualifying jobs.

¹ Fraud. (n.d.). In Merriam Webster online. Retrieved from <http://www.merriam-webster.com/dictionary/fraud>

² Falsify. (n.d.). In Merriam Webster online. Retrieved from <http://www.merriam-webster.com/dictionary/falsify>

Report Fraud, Falsification or Misconduct

If a recruiter observes fraud, falsification or misconduct, some things he or she can do include:

- If the recruiter has been asked to do something he or she believes is inappropriate, the recruiter should make it clear that he or she isn't comfortable with what is being asked.
- Write down what happened with as much detail as possible (if others witnessed what happened, have them write down what they observed as well).
- Report what happened to the appropriate person (if the supervisor is involved, the recruiter should report the problem to someone who is at a higher level within the MEP).

The recruiter should not do things that he or she believes to be wrong, and should follow up on any concerns until they have been properly addressed. Furthermore, if the recruiter suspects that another recruiter is enrolling children in the MEP who are not eligible, the recruiter is obligated to report that as well. If the state MEP does not take the recruiter's concern seriously, the recruiter should report the problem to the federal Office of Migrant Education (OME). Current contact information is available on ED's website at

<http://www2.ed.gov/about/offices/list/oese/ome/aboutus.html#contact>.

Anyone suspecting fraud, waste or abuse involving ED's funds or programs should also call or write to the Office of the Inspector General's (OIG) Hotline. The OIG keeps these complaints confidential; it will not release the recruiter's name, address or any other identifying information. The OIG can be contacted using any of the following methods:

- Call the OIG Hotline's toll free number 1-800-MIS-USED. The Hotline's operating hours are from 9:00 a.m. until 4:00 p.m. Eastern Time, Monday through Friday, except for holidays.
- Send an e-mail message to oig.hotline@ed.gov.
- Complete and submit an electronic [complaint form](#), which is available on the ED's website at: <http://www2.ed.gov/about/offices/list/oig/hotline.html>.
- To ensure complete anonymity, download a hardcopy of [the special complaint form](#), complete, and mail to:

Inspector General's Hotline
Office of Inspector General
U.S. Department of Education
400 Maryland Avenue, SW
Washington, D.C. 20202-1510

Fraud or intentional falsification is not something that should be taken lightly. Remember that the recruiter commits to this Code of Ethics every time he or she signs a COE, which includes the following statement:

I certify that based on the information provided to me, which in all relevant aspects is reflected above, I am satisfied that these children are migratory children as defined in 20 U.S.C. 6399(2) and implementing regulations, and thus eligible as such for MEP services. I hereby certify that, to the best of my knowledge, the information is true, reliable, and valid and I understand that any false statement provided herein that I have made is subject to fine or imprisonment pursuant to 18 U.S.C. 1001.

The recruiter has a special opportunity to help migrant children receive needed educational services through the MEP. Every service that is provided starts with a competent and qualified recruiter who is doing his or her job correctly and ethically.

Appendix VIII: Sample Interview Script

SECTION 1: LAY THE GROUNDWORK FOR THE INTERVIEW	
Introduce Yourself	<p>Hello, my name is _____. I work with the Migrant Education Program.¹ It is a program that is related with the local school that could help you or your children with their education. If I can speak to you for a few minutes about your family and your work, some members of your family might be eligible for services. Even if you are not eligible, I know of some other helpful programs that I can tell you about.</p> <p><i>Hola, soy _____. Trabajo para el Programa de Educación al Migrante. Es un programa que está relacionado con la escuela local que podría ayudarlo a usted o a sus hijos con su educación. Me gustaría poder conversar unos minutos con usted acerca de su familia y su trabajo; tal vez algunos miembros de su familia sean elegibles para los servicios. Incluso aunque usted no sea elegible, sé de otros útiles programas sobre los que podría informarle.</i></p>
Build Rapport	(Look for connections that you can make with the family. For example, did your children go to the same school that the children attend? Finding something positive to say about the parent or child may also help to put the family at ease.)
No Children	<p>If you don't have any children, I might be able to tell you about some programs that could help <u>you</u> with your education.</p> <p><i>Si no tiene hijos, podría informarle de algunos programas que podrían ayudarlo a <u>usted</u> con su educación.</i></p>
Credentials	<p>Here is my identification (or business card). It shows that I work for the Migrant Education Program.</p> <p><i>Esta es mi identificación (o tarjeta de presentación). Muestra que trabajo para el Programa de Educación al Migrante.</i></p>
Not in sales	<p>I am not selling anything. I have some things I would like to give you for free. Here is a brochure about the Migrant Education Program and [give the family other free promotional items like the school's student handbook].</p> <p><i>Yo no vendo nada. Tengo algunas cosas que me gustaría regalarle. Aquí hay un folleto acerca del Programa de Educación al Migrante y [give the family other free promotional items like the school's student handbook].</i></p>

¹ Some programs avoid using the word “migrant” because they are concerned that families may confuse it with the word “*migra*,” which refers to the immigration service in Spanish. Other programs avoid using the word “migrant” because some MEP eligible families may not consider themselves migrant farmworkers due to ethnical stereotypes. If this is the case, they may unknowingly cast off the interview before they had a chance to hear how it may apply directly to their family.

Privacy	<p>The information you share with me is private, and will be used for educational purposes only. I don't share information with other agencies or government departments unless I have your permission to do so.</p> <p><i>La información que usted comparte conmigo es privada y se usará solo para fines educacionales. No comparto información con otras agencias o departamentos de gobierno a menos que usted me dé su permiso para hacerlo.</i></p>
Better Time	<p>Is this a good time to talk? I can talk with you at another time if that would be more convenient</p> <p><i>¿Es un buen momento para hablar? Podría hablar con usted otro día si sería más conveniente.</i></p>
SECTION 2: TRANSITION TO THE INTERVIEW	
Explain the interview	<p>The Migrant Education Program helps families that have worked in agriculture or fishing. I need to ask some questions about you and your family to find out if this program can help you. For example, I'll ask about your ages, the work you've done, and where you have lived and gone to school. We will talk about those things for a little while and then I will summarize what you have told me.</p> <p><i>El Programa de Educación al Migrante ayuda a las familias que han trabajado en agricultura o pesca. Necesito hacerle algunas preguntas acerca de usted y su familia para determinar si este programa puede serle de ayuda. Por ejemplo, le voy a preguntar sus edades, el trabajo que han realizado y dónde han vivido e ido a la escuela. Vamos a conversar acerca de esas cosas por un momento y luego voy a resumir lo que me haya dicho.</i></p>
Repeat Questions	<p>Just to be sure that I understood what you told me, I might repeat questions, or ask for the same information in a different way.</p> <p><i>Solo para estar seguro que entendí lo que me dijeron, podría repetir preguntas, o bien pedir la misma información de una manera distinta.</i></p>
Probes	<p>If you don't remember something, I will try to help you by asking other questions.</p>
Documents	<p>If you have documents that have information about your family, you can use them to help you answer my questions.</p> <p><i>Si no recuerdan algo, voy a tratar de ayudarles haciendo otras preguntas. Si tiene documentos que contengan información acerca de su familia, puede usarlos para ayudarse a responder mis preguntas.</i></p>

Time to Recall	<p>If you don't know the answers to some of my questions, I can always call you or come by later to finish up our conversation.</p> <p><i>Si no conoce las respuestas a algunas de mis preguntas, siempre puedo llamarlo o venir más tarde para terminar nuestra conversación.</i></p>
Personal Information	<p>I apologize if some of the questions I'll ask seem very personal. I don't mean to offend you, but I need this information to see if this program can help you.</p> <p><i>Discúlpeme si algunas de las preguntas que le haga parecen muy personales. No tengo intención de ofenderlo, pero necesito esta información para ver si este programa puede serle de ayuda.</i></p>

SECTION 3: GATHER INFORMATION ON CHILD ELIGIBILITY			
	Yes	No	Notes
FACTOR 1: AGE OF ELIGIBLE CHILDREN			
Is the child younger than age 22?			
1. Do you have any children? ¹ <i>¿Tiene hijos?</i> a. Are you a parent? <i>¿Es usted padre?</i> b. Do you have any stepchildren? <i>¿Tiene algún hijastro?</i>			
2. Are there any children living with you in your house who are younger than 22? <i>¿Hay algún niño que viva con usted en su casa que sea menor de 22 años?</i> a. Are you a guardian for any children? <i>¿Es tutor de algún niño?</i> b. Do you help provide for (support) any children? <i>¿Contribuye usted a (la manutención) de algún niño?</i> c. Do you help provide for (support) any younger brothers or sisters? <i>¿Contribuye usted a (la manutención) de algún hermano o hermana menor?</i> d. Do you help provide for (support) any other family members (e.g., nieces or nephews)? <i>¿Contribuye usted a (la manutención) de otros miembros de la familia (por ejemplo, sobrinas o sobrinos)?</i>			
3. What are their names and ages? <i>¿Cómo se llaman y qué edades tienen?</i> a. Are any of your children younger than 22? <i>¿Alguno de sus hijos es menor de 22 años?</i> b. How old was each child on his or her last birthday? <i>¿Qué edad cumplió cada niño en su último cumpleaños?</i>			List their names and dates of birth on the COE form.
4. Are you younger than 22? <i>¿Es usted menor de 22 años? (If yes, proceed to a-c.)</i> a. How old are you? <i>¿Qué edad tiene?</i> b. When were you born? <i>¿Dónde nació?</i> c. How old were you on your last birthday? <i>¿Qué edad cumplió en su último cumpleaños?</i>			
5. Are you married? <i>¿Es casado(a)?</i> a. Do you live with a partner (mate, companion, spouse)? <i>¿Vive con alguien (amigo(a), compañero, esposo(a))?</i>			

¹ Throughout this document, “your children” refers to any child(ren) the interviewee has reported having responsibility for (e.g., providing support).

<p>b. Does your spouse live in this area? <i>¿Su esposo(a) vive en esta área?</i></p> <p>c. Is your spouse younger than 22? <i>¿Es su esposo(a) menor de 22 años?</i> (If yes proceed to d.)</p> <p>d. How old was your spouse on his/her last birthday? <i>¿Qué edad cumplió su esposo(a) en su último cumpleaños?</i></p>			
<p>FACTOR 2: SCHOOL COMPLETION² Is the child a high school graduate or holder of a high school equivalent certificate?</p>			
<p>6. (If the family has older children or young adults.) Have any of the older children graduated from high school? <i>¿Alguno de los hijos más grandes se graduó de secundaria?</i></p> <p>a. Have any of the children completed preparatoria/bachillerato (or the equivalent) in their/your home country? [Preparatoria/bachillerato is the term used for high school in the Spanish language.] <i>¿Alguno de los niños completó preparatoria/bachillerato (o el equivalente) en el país natal suyo/de ellos?</i></p> <p>b. Have any of the children obtained a general equivalency degree (GED)? <i>¿Alguno de los niños obtuvo un grado de equivalencia general (GED)?</i></p> <p>c. Did they take a test and receive a certificate that said they passed high school? <i>¿Rindieron ellos una prueba y recibieron un certificado que indica que aprobaron la secundaria?</i></p>			
<p>7. If under age 22 and the worker is the ‘child’/OSY ask: Have you graduated from high school? <i>¿Usted se graduó de secundaria?</i></p> <p>a. How many years did you go to school? <i>¿Cuántos años fue usted a la escuela?</i></p> <p>b. Did you complete <i>preparatoria</i> (or the equivalent) in your home country? <i>¿Completó usted la preparatoria (o el equivalente) en su país natal?</i></p> <ul style="list-style-type: none"> • Did you get a GED? <i>¿Obtuvo usted un GED?</i> 			
<p>8. If under age 22 and the worker’s spouse is also a ‘child’/OSY ask:</p> <p>a. Did your spouse graduate from high school? <i>¿Su esposo(a) se graduó de secundaria?</i></p> <p>b. Did he/she complete preparatory (or the equivalent) in his/her</p>			

² The recruiter should learn which children are still entitled to a free public education in his or her state. For example, in most states children are no longer entitled to a free public education once they have reached a specific age. Furthermore, what constitutes “school completion” may vary from state to state since each state sets its own requirements for high school diplomas, General Educational Development tests (GED) and “Certificates of Completion.” Under state law in some states, having been awarded a GED, a certificate of completion, a certificate of course completion, or a certificate by any other name does not terminate a person’s right to pursue a high school diploma. In other states, the opposite would be true.

<p>home country? <i>¿Completó él/ella la preparatoria (o el equivalente) en su respectivo país natal?</i></p> <p>c. Did he/she get a GED? <i>¿Obtuvo él/ella un GED?</i></p>			
<p>FACTOR 3: MOVED ACROSS SCHOOL DISTRICT BOUNDARIES OR MOVED WITHIN THE LAST 36 MONTHS</p> <p>Has the child moved across school district lines³ on his or her own, or with or to join an agricultural or fishing worker in the last 36 months?</p>			
<p>9. Have you ever moved? <i>¿Alguna vez se ha trasladado?</i></p> <p>a. How long has your family been living in [name of current home town]? <i>¿Por cuánto tiempo su familia ha estado viviendo en [name of current home town]?</i></p> <p>b. Have you always lived here (community, house, apartment)? <i>¿Usted siempre ha vivido aquí?</i></p> <p>c. Did you ever travel (live, go) anywhere else? <i>¿Alguna vez ha viajado (vive, va) a otro lado?</i></p> <p>d. Have you traveled in the last three years? <i>¿Ha viajado en los últimos tres años?</i></p> <p>e. Where have you gone (been) recently? <i>¿Dónde ha ido (estado) recientemente?</i></p> <p>f. Have your children ever gone to a different school? <i>¿Alguna vez sus hijos han asistido a una escuela diferente?</i></p>			
<p>10. Where did you move from? Where did you move to? <i>¿Desde dónde se trasladó usted? ¿Hacia dónde se trasladó usted?</i></p> <p>a. Did your children go to a different school after you moved? <i>¿Sus hijos iban a una escuela diferente después de que se trasladaron?</i></p> <p>b. Did your children have to change schools because you moved? <i>¿Sus hijos tuvieron que cambiarse de escuela por el traslado de ustedes?</i></p>			

³ For a state that is comprised of a single district: has moved from one administrative area to another within such district; or resides in a school district of more than 15,000 square miles and migrates a distance of 20 miles or more to a temporary residence to engage in a fishing activity. (This provision only applies to Alaska.)

<p>11. Who moved with you? <i>¿Quién se mudó con usted?</i></p> <p>a. Did your spouse move? <i>¿Se mudó su esposo/a?</i></p> <p>b. Did all of your children move? <i>¿Se mudaron todos sus hijos?</i></p> <p>c. Did the children move with you? <i>¿Los niños se mudaron con usted?</i></p> <p>d. Which of your children did <u>not</u> move? <i>¿Cuál(es) de los niños no se mudó?</i></p> <p>e. Will/Did any of your children join you here later? <i>¿Algún(o) de su(s) hijo(s) se vendrá acá más adelante?</i></p> <p>f. Have you ever moved after your children moved? <i>¿Alguna vez se ha trasladado después de que sus hijos se mudaron?</i></p> <p>g. How long after you moved did (name of family member) join you? <i>¿Al cuánto tiempo desde que usted se mudó se le unió (name of family member)?</i></p> <p>h. When will your children join you? <i>¿Cuándo se le unirán sus hijos?</i></p>			A separate COE would need to be completed for any child who had a different qualifying arrival date.
<p>12. When did you last move? <i>¿Cuándo fue la última vez que se mudó?</i></p> <p>a. When was the last time (most recent) that you moved to look for work in agriculture or fishing? <i>¿Cuándo fue la última vez (la más reciente) en que usted se trasladó en busca de trabajo en agricultura o pesca?</i></p> <p>b. When did you arrive here? (date or approximate date; month & year) <i>¿Cuándo llegó usted acá?</i></p> <p>c. Did you move within the last three years? <i>¿Se ha mudado en los últimos tres años?</i></p> <p>d. If you can't remember the date when you moved, do you remember: <i>Si no puede recordar la fecha en que se mudó, recuerda:</i></p> <ul style="list-style-type: none"> • if it was warm or cold when you moved? <i>¿si era tiempo cálido o frío cuando se mudó?</i> • what grade your child was in? <i>¿en qué curso iba su hijo?</i> • whether there was a holiday or family event that occurred around the time you moved? <i>¿si había una festividad o evento familiar que haya ocurrido alrededor de la fecha en que usted se mudó?</i> • if it was before or after [insert a major historical event or holiday]? <i>¿si fue antes o después [insert a major historical event or holiday]?</i> 			
<p>FACTOR 4: PURPOSE OF MOVE</p> <p>Was one <u>purpose</u> of the worker's move to seek or obtain qualifying work out of economic necessity?</p>			
<p>13. Why did you move here? <i>¿Por qué se trasladó aquí?</i></p> <p>a. What are some of the reasons you moved?</p>			

<p><i>¿Cuáles son algunas razones por las que usted se mudó?</i></p> <p>b. What would you say is the most important reason you moved? <i>¿Cuál diría usted que es la razón más importante por la que usted se mudó?</i></p> <p>c. What kind of work were you trying to find? <i>¿Qué tipo de trabajo estaba tratando de encontrar?</i></p> <p>d. How did you know this kind of work was available? <i>¿Cómo supo usted que este tipo de trabajo estaba disponible?</i></p> <p>e. Would you have moved if this work was not available? <i>¿Se habría mudado si este trabajo no estuviese disponible?</i></p> <p>f. Did you know this work was available before you moved? <i>¿Sabía usted que este trabajo estaba disponible antes de que se mudara?</i></p> <p>g. How did you know the work was available? <i>¿Cómo supo usted que el trabajo estaba disponible?</i></p>			
<p>14. If you moved to find work, are you doing this type of work now? <i>Si se mudó para encontrar trabajo, ¿está haciendo este tipo de trabajo en estos momentos?</i></p> <p>a. Did [name of family member] find the kind of work he/she was looking for? <i>¿[name of family member] encontró el tipo de trabajo que él/ella andaba buscando?</i></p>			
<p>15. If the answer to question 14 is “no,” ask the following:</p> <p>a. What did you do to look for work? <i>¿Qué hizo usted para buscar trabajo?</i></p> <p>b. Did you fill out an application for employment? <i>¿Completó una solicitud de empleo?</i></p> <p>c. Where did you apply? <i>¿A dónde postuló usted?</i></p> <p>d. Why were you not able to find the work? <i>¿Por qué no logró encontrar trabajo?</i></p> <p>e. Can you tell me the names of employers that you contacted? <i>¿Puede decirme los nombres de los empleadores que usted contactó?</i></p> <p>f. To whom did you speak? <i>¿Con quién habló?</i></p> <p>g. When did you apply for this work? <i>¿Cuándo postuló usted a este trabajo?</i></p> <p>h. Did someone take you there? What is the person’s name? <i>¿Alguien lo llevó ahí? ¿Cómo se llama la persona?</i></p> <p>i. Before you moved here, were you employed? <i>Antes de que se mudara acá, ¿dónde estaba empleado?</i></p> <p>j. What kind of work did you do before you moved here? Was anyone else who was part of your household employed?</p>			

<p><i>Antes de que mudara acá, ¿había algún otro miembro de su hogar que tuviera empleo?</i></p> <p>k. What kind of work did they do? <i>¿Qué tipo de trabajo hacía?</i></p> <p>l. Did they have to work to help pay for food, clothing, and housing? <i>¿Tenía él/ellos que trabajar para ayudar a pagar por comida, vestuario y vivienda?</i></p> <p>m. Have you done this type of work before? <i>¿Alguna vez ha hecho este tipo de trabajo?</i></p> <p>n. Where and when? <i>¿Dónde y cuándo?</i></p> <p>o. Where do you work now? What kind of work do you do there? <i>¿Dónde trabaja ahora? ¿Qué tipo de trabajo hace ahí?</i></p>			
<p>16. Are you employed anywhere else? <i>¿Tiene empleo en algún otro lado?</i></p>			
<p>17. Does your family have other sources of income? (e.g., government payments) <i>¿Su familia tiene alguna otra fuente de ingreso? (por ejemplo, subsidios gubernamentales)</i></p>			
<p>18. Do other people in your family have other work? <i>¿Alguna otra persona en su familia tiene otro trabajo?</i></p> <p>a. What work do they do? <i>¿Qué trabajo hace(n)?</i></p> <p>b. Do they have to work to help pay for food, clothing, and housing? <i>¿Tienen ellos que trabajar para ayudar a pagar por comida, vestuario y vivienda?</i></p> <p>c. Is the income that other family members earn enough to support your family? <i>¿El ingreso que otro(s) miembro(s) de la familia gana basta para mantener a su familia?</i></p>			
<p>19. How many dependents are in your household? <i>¿Cuántos dependientes hay en su hogar?</i></p> <p>a. How many people do you provide for (e.g., support)? <i>¿A cuántas personas mantiene (es decir, paga su manutención)?</i></p> <p>b. How many people in your household <u>don't</u> work? <i>¿Cuánta gente que <u>no</u> trabaja hay en su hogar?</i></p>			
<p>20. Do you need your current work to pay for food, clothing, and housing? <i>¿Necesita usted su actual trabajo para pagar por comida, vestuario y vivienda?</i></p>			

<p>FACTOR 5: QUALIFYING WORK Was the employment seasonal or temporary AND agricultural or fishing?</p>			
<p>21. What kind of work do you do? <i>¿Qué tipo de trabajo hace?</i></p> <p>a. Where do you work? <i>¿Dónde trabaja?</i></p> <p>b. What do you do there each day? <i>¿Qué hace ahí cada día?</i></p> <p>c. If you didn't find the work you wanted, what kind of work were you looking for? <i>Si no encontró el trabajo que usted quería, ¿qué tipo de trabajo estaba buscando?</i></p>			
<p>22. When you moved here originally, did you plan to stay permanently? <i>¿Cuando usted se mudó originalmente acá, ¿tenía planes de quedarse permanentemente?</i></p> <p>a. How long do you plan to do this work? <i>¿Por cuánto tiempo planea hacer este trabajo?</i></p> <p>b. Were you hired for a certain amount of time? <i>¿Lo contrataron por un período de tiempo determinado?</i></p> <p>c. When does this job end? <i>¿Cuándo termina este trabajo?</i></p> <p>d. When this work ends, will you do other work for your current employer? <i>Cuando este trabajo termine, ¿hará otro trabajo para su actual empleador?</i></p> <p>e. Do you always do the same thing at work? <i>¿Usted siempre hace lo mismo en el trabajo?</i></p> <p>f. How long did you do this work? <i>¿Por cuánto tiempo hizo este trabajo?</i></p>			
<p>23. Do you ever take time off from your work and travel to another place? <i>¿Alguna vez se toma una pausa en su trabajo y viaja a otro lugar?</i></p> <p>a. Do you go back to your home country? <i>¿Usted regresa a su país natal?</i></p> <p>b. Why do you go? (e.g., visit family, wedding, festival, save on expenses, maintain property in home country, work in home country) <i>¿Por qué va? (por ejemplo, visita familia, boda, festival, ahorrar costos, mantiene propiedad en país natal, trabaja en país natal)</i></p> <p>c. Could you have continued to work or did your job end? <i>¿Podría haber seguido trabajando o su trabajo terminó?</i></p> <p>d. Were you still employed while you were gone? <i>¿Usted seguía estando empleado mientras estuvo lejos?</i></p> <p>e. Were you paid for your vacation time? <i>¿Sus vacaciones fueron pagadas?</i></p> <p>f. Were you laid off when you left? <i>¿Lo despidieron cuando se marchó?</i></p>			

<p>g. Did you have to reapply for your job when you came back? <i>¿Tuvo que volver a postular a su trabajo cuando regresó?</i></p> <p>h. Did you think the same company would hire you again? <i>¿Pensó que la misma empresa lo volvería a contratar?</i></p> <p>i. How long have you worked for the same employer? <i>¿Por cuánto tiempo ha trabajado para el mismo empleador?</i></p> <p>j. How long are you gone when you leave? <i>¿Por cuánto tiempo estuvo lejos cuando se marchó?</i></p> <p>k. How long have you lived in this community? <i>¿Por cuánto tiempo ha vivido en esta comunidad?</i></p> <p>l. Do you own a home? <i>¿Es dueño de una vivienda?</i></p> <p>m. Do you return to the same home? <i>¿Regresa a la misma vivienda?</i></p> <p>n. Do you sublet your home (apartment) while you are gone? <i>¿Subarrienda su vivienda (apartamento) mientras está lejos?</i></p> <p>o. Do you go back to your home country because it's cheaper to live there? <i>¿Usted regresa a su país natal porque es más barato vivir allá?</i></p> <p>p. How many miles do you travel when you move? <i>¿Cuántas millas recorre cuando se muda?</i></p> <p>q. How often do you take a break from your job? (e.g., every year?) <i>¿Con qué frecuencia se toma una pausa de su trabajo? (por ejemplo, todos los años)</i></p> <p>r. Do your children miss school while you are gone? If so, how much do they miss? <i>¿Sus hijos faltan a la escuela cuando usted está lejos? En caso afirmativo, ¿cuánto faltan?</i></p>			
COMPLETE COE FORM			
<p>24. Now I want to fill out the remaining information on the Certificate of Eligibility (COE) Form for the Migrant Education Program.</p> <p><i>Ahora necesito que complete la información restante en el Formulario del Certificado de Elegibilidad (COE) para el Programa de Educación al Migrante.</i></p>			

SECTION 4: TRANSITION TO THE CONFIRMATION PROCESS

Wrap Up	<p>You've been very helpful. I'm going to follow up with my office so they can decide if you and your family are eligible for the program. After all this discussion, do you have anything else to add, or any questions for me?</p> <p><i>Gracias por cooperar. Voy a presentar su caso en mi oficina para que ellos decidan si usted y su familia son elegibles para el programa. Después de todo lo que hemos conversado, ¿tiene algo más que agregar o quiere preguntarme algo?</i></p>
Introduce Summary	<p>Now I am going to summarize some of the information you told me. Please listen carefully and see if I understood the information that you provided. If I didn't understand something you said, PLEASE let me know and I will change it.</p> <p><i>Ahora voy a resumir parte de la información que me contó. Por favor escuche con atención y vea si entendí la información que usted me dio. Si no entendí algo que haya dicho, POR FAVOR indíquemelo para cambiarlo.</i></p>

SECTION 5A: CONFIRM RESPONSES—FOR CHILDREN

Names & Ages	<p>Your child(ren) _____ [name of child(ren)], Age(s): _____ (respectively),</p> <p><i>Su hijo(s) _____ [name of child(ren)], de _____ años de edad [age(s) (respectively)],</i></p>
School Completion	<p>have not graduated from high school or obtained a GED, and</p> <p><i>no se ha(n) graduado de secundaria ni obtenido un GED, y</i></p>
Move	<p>moved on _____ (month, day, year) with or to join _____ (name of worker).</p> <p><i>se mudó/mudaron el _____ (month, day, year) con o para unirse a _____, (identify name of worker)</i></p>
Worker	<p>The worker in your family is the child(ren)'s parent, or guardian or (other) _____ (identify relationship to child).</p> <p><i>El trabajador en su familia es el padre, o tutor del niño(s) u (otro) _____ (identify relationship to child).</i></p>
Purpose of Move	<p>The move was made to enable the worker to seek (i.e., looked but did not find) or obtain (i.e., found)</p> <p><i>El traslado se hizo para permitir que el trabajador buscara (es decir, buscó pero no encontró) u obtuviera (es decir, encontró) empleo temporal o estacional</i></p>
Qualifying Work— Temp or Seasonal	<p>temporary or seasonal employment</p> <p><i>empleo temporal o estacional</i></p>

Qualifying Work— Agriculture or Fishing	doing _____ (identify qualifying activity), agricultural or fishing work. <i>haciendo _____ (identify qualifying activity)</i> <i>trabajo agrícola o pesquero .</i>
Purpose of Move- Economic Necessity	The qualifying work is significant to providing a living for you or your family because _____. <i>El trabajo calificado es importante para proveer sustento para usted o su familia porque _____.</i>
SECTION 5B: CONFIRM RESPONSES—FOR OUT-OF-SCHOOL YOUTH	
Name & Age	You, _____, are _____ (age), and <i>Usted, _____ de _____ años de edad (age), y</i>
School Completion	have not graduated from high school or obtained a GED, and <i>no se ha graduado de secundaria ni obtenido un GED, y</i>
Move	moved on _____ (month, day, year) <i>se mudó el _____ (month, day, year)</i>
Purpose of Move	to seek or obtain <i>para buscar u obtener</i>
Qualifying Work- Temp or Seasonal	temporary or seasonal employment <i>empleo temporal o estacional</i>
Qualifying Work- Agriculture or Fishing	doing _____ (identify qualifying activity) agricultural or fishing work . <i>haciendo _____ (identify qualifying activity)</i> <i>trabajo agrícola o pesquero .</i>
Purpose of Move- Economic Necessity	The qualifying work is significant to providing a living for you or your family because _____. <i>El trabajo calificado es importante para proveer sustento para usted o su familia porque _____.</i>

SECTION 6: CLOSE THE INTERVIEW	
Sign COE Form	<p>If the information that I have confirmed with you is correct, the interview is now over. Would you please sign the Certificate of Eligibility (COE) form here to confirm that the information that you have provided is correct? Your signature simply means that you confirm that I've written what you told me.</p> <p><i>Si la información que he confirmado con usted es correcta, la entrevista ha terminado. ¿Sería tan amable de firmar el formulario de Certificado de Elegibilidad aquí para confirmar que la información que ha entregado está correcta? Su firma solo significa que usted confirma que yo escribí lo que usted me contó.</i></p>
Give Copy of COE to family/youth	<p>Here is a copy¹ of the form that I went over with you that you can keep so you have a record of the questions that I asked you. <i>[Please give the family/youth a copy of the form in their native language, if possible.]</i> If your child/you is/are determined to be eligible, I will mail a completed copy of this form to you. <i>[If the date the family signed and the date the interviewer signed are different, a brief explanation should be provided in the comment section.]</i></p> <p><i>Aquí hay una copia del formulario que repasé con usted y que puede conservar para que tenga un registro de las preguntas que le hice. [Please give the family/youth a copy of the form in their native language, if possible.] Si se determina que su hijo/usted es elegible, le enviaré a usted por correo una copia completa de este formulario. [If the date the family signed and the date the interviewer signed are different, a brief explanation should be provided in the comment section.]</i></p>
Remind About Privacy	<p>The information you share with me is private, and will be used for educational purposes only. I don't share information with other agencies or government departments unless I have your permission to do so. <i>[Additional information may be explained regarding Family Educational Rights and Privacy Act (FERPA).]</i></p> <p><i>La información que usted comparta conmigo es privada y se usará solo para fines educacionales. No comparto información con otras agencias o departamentos de gobierno a menos que usted me dé su permiso para hacerlo. [Additional information may be explained regarding Family Educational Rights and Privacy Act (FERPA).]</i></p>

¹ Some MEPs use COEs that are printed on three color NCR forms so the family/youth can immediately receive an original copy of the completed COE.

Appendix IX: New Recruiter Self Check

Child Eligibility for the Title I, Part C Migrant Education Program

Base your answers to these scenarios on the basic child eligibility factors chart provided on the following page.

1. A family with three children, ages 13, 15, and 23, moved in September of this year from Arizona to New York to pick tomatoes while they were in season. This is the family's only livelihood. Are the children eligible for the MEP?
2. A male, age 19, who graduated from high school in Louisiana, moved from Louisiana to Michigan last year to harvest apples in order to help his family with their living expenses. Is he eligible for the MEP?
3. A family with two children, ages 11 and 14, moved ten miles down the road last month to pick blueberries as they were coming into season. The children changed schools, but they remain in the same school district. This is the family's only means of income. Do the children qualify for the MEP based on this move?
4. A young couple, ages 18 and 20 (neither of whom have a high school diploma or GED), moved from Texas to Montana two months ago. The man moved to Montana because his family told him that local builders are hiring in construction. Upon the move, the man obtains a construction job. The young woman did not plan to work. Is anyone eligible for the MEP?
5. A couple with a four-year-old boy moved from Arizona to Georgia three months ago to pick peaches. When they finish picking peaches, the family plans to move up the coast to New Jersey where they will pick blueberries. The money they earn from picking crops is the family's only income. Is the child eligible for the MEP?
6. Anna, age 18, works at a processing plant in Arkansas. Her friends told her that the Tyson plant in Iowa is hiring temporary workers in preparation for this holiday season. In September, Anna moves to Iowa to work at the Tyson plant. When she arrives, the Tyson plant hires her to work for a three-month period cutting poultry. This is her only means of income. Assuming that Anna has not graduated from high school and does not have her GED, is she eligible for the MEP?
7. This past October, a recruiter finds a family with four children (ages 3, 4, 7, and 9) who moved from Mexico to California to harvest various crops. Both parents work in the fields, picking crops. This work is their only source of income. The mother tells the recruiter that they moved from Mexico in March of this same year. When the harvest season is over, the family plans to move back to Mexico. Are the children eligible for the MEP?

8. During the holiday season, a couple and their two sons (ages 15 and 17) go to their cabin in the neighboring state for a three to four week period. Each year on their vacation, the boys work with a local farmer tending to cattle. The money from this job allows them to earn some extra cash that they use to buy new hunting equipment. Neither son has graduated from high school or earned a GED. Are the children eligible for the MEP?
9. In May 2007, a family moved from Texas to Michigan with their children, ages five and eight, to pick the local crops in season. A recruiter finds them in 2012 and wants to qualify them for the MEP because the family is still picking crops and this is their only means of livelihood. The family has not moved since 2007. Are the children eligible for the MEP?
10. A family with children ages two and six moved from Idaho to Montana two years ago. The father moved to Montana in search of a permanent job as a ranch hand. He was hired to be the crew chief on the farm on a year-round basis. The mother stays at home with the children. Are the children eligible for the MEP?

*Answers can be found on page 211.

Basic Child Eligibility Factors Chart

In order to be eligible for the Title I, Part C Migrant Education Program (MEP), a child must meet **all** of the following basic eligibility criteria. The **basic eligibility criteria** are denoted in the chart below with a check mark to the right. If the answer to even one of these basic criteria is no, the child is not eligible for the MEP. If the recruiter is unclear about how to answer a statement, the recruiter must resolve the issue by (1) collecting any additional information that is needed to make a determination, and (2) following the state's procedure for resolving eligibility questions (e.g., consulting with a supervisor, asking the SEA to make a determination, etc.) **before** the child can be considered eligible for the program.

Basic Child Eligibility Factors Chart		Yes	No
1. Age: The child is younger than age 22.		✓	
2. School Completion: The child is eligible for a free public education through grade 12 under state law. ²		✓	
3. Move:			
The child moved on his or her own as a migratory agricultural worker/fisher OR the child moved with or to join/precede a parent, spouse, or guardian who is a migratory agricultural worker/fisher, AND		✓	
The move was from one school district to another, AND		✓	
The move was a change from one residence to another residence, AND		✓	
The move was due to economic necessity, AND		✓	
The move occurred within the past 36 months.		✓	
4. Purpose of Move: <i>One purpose</i> of the worker's move was to seek or obtain qualifying work. <ul style="list-style-type: none"> • The worker moved to obtain qualifying work and obtained it, OR • The worker moved to obtain any work and obtained qualifying work soon after the move, OR • The worker moved for qualifying work specifically, but for reasons beyond his or her control, did not obtain the work, AND • The worker has a prior history of moves to obtain qualifying work, OR • There is other credible evidence that the worker actively sought qualifying work soon after the move. 		✓	
5. Qualifying Work:			
The employment is seasonal or temporary, AND		✓	
The work is agricultural or fishing.		✓	

² The recruiter should find out which older children are still entitled to a free public education in his or her state. If a question arises (e.g., the child has a secondary school degree issued by another country or has received a certificate of completion in lieu of a diploma), the recruiter should find out from state officials whether the child is entitled to continue to pursue a high school diploma in that state.

New Recruiter Self-Check Answer Guide

1. **Question:** A family with 3 children, ages 13, 15, and 23, moved in September of this year from Arizona to New York to pick tomatoes while they were in season. This is the family's only livelihood. Are the children eligible for the MEP?

Review the basic child eligibility factors:

✗	1. Age of Eligible Children. The children ages 13 and 15 meet the age requirement. The oldest child is not eligible because she is not younger than 22 years of age
✓	2. School Completion. Presumably, neither the 13 nor 15 year-old have finished high school or obtained a GED.
✓	3. Move. The children moved across school district lines, with their parents who are migratory agricultural workers (i.e., Arizona to New York). The move occurred within the past 36 months (i.e., September of this year). The family moved due to economic necessity (their only livelihood).
✓	4. Purpose of Move. One <i>purpose</i> of the worker's move was to seek or obtain qualifying work. a. The family moved to obtain qualifying work (e.g., to pick tomatoes) and obtained work.
✓ ✓ ✓	5. Qualifying Work. b. Agricultural or Fishing. The work qualifies because it is agricultural work. c. Temporary or Seasonal. The employment qualifies because it is seasonal.
Answer: The two youngest children are eligible. The oldest child is not younger than age 22.	

2. **Question:** A male, age 19, who graduated from high school in Louisiana, moved from Louisiana to Michigan last year to harvest apples in order to help his family with their living expenses. Is he eligible for the MEP?

Review the basic child eligibility factors:

✓	1. Age of Eligible Children. The youth meets the age requirement because he is younger than 22 years of age (i.e., 19).
✗	2. School Completion. He is not eligible for the MEP because he has graduated from high school.
✓	3. Move. He moved across school district lines, on his own, as a migratory agricultural worker (i.e., Louisiana to Michigan). The move occurred within the past 36 months (i.e., last year).

✓	<p>4. Purpose of Move. One <i>purpose</i> of the worker’s move was to seek or obtain qualifying work.</p> <p>a. He moved to obtain qualifying work (i.e., to work in a crop harvest) and obtained the work.</p>
✓ ✓ ✓	<p>5. Qualifying Work.</p> <p>b. Agricultural or Fishing. The work qualifies because it is agricultural work.</p> <p>c. Temporary or Seasonal. The employment qualifies because it is seasonal.</p>
<p>Answer: <u>Not eligible.</u> Worker has graduated high school.</p>	

<p>3. Question: A family with two children, ages 11 and 14, moved ten miles down the road last month to pick blueberries as they were coming into season. The children changed schools, but they remain in the same school district. This is the family’s only means of income. Do the children qualify for the MEP based on this move?</p> <p>Review the basic child eligibility factors:</p>	
✓	<p>1. Age of Eligible Children. The children meet the age requirement because they are younger than 22 years of age (i.e., 11 and 14).</p>
✓	<p>2. School Completion. The children have not graduated from high school or obtained a GED.</p>
✗	<p>3. Move. The children have not moved across school district lines. Therefore, they are not eligible for the MEP even though they moved with their parents who are migratory agricultural workers; the move occurred within the past 36 months (i.e., last month) and was for economic necessity (family’s only income).</p>
✓	<p>4. Purpose of Move. One <i>purpose</i> of the worker’s move was to seek or obtain qualifying work.</p> <p>a. The family moved to obtain qualifying work (i.e., to work in a crop harvest) and obtained the work.</p>
✓ ✓ ✓	<p>5. Qualifying Work.</p> <p>a. Agricultural or Fishing. The work qualifies because it is agricultural work.</p> <p>b. Temporary or Seasonal. The employment qualifies because it is seasonal.</p>
<p>Answer: <u>Not eligible.</u> Even though the children changed schools, family <i>did not move across school district lines</i></p>	

<p>4. Question: A young couple, ages 18 and 20 (neither of whom have a high school diploma or GED), move from Texas to Montana two months ago. They moved to Montana because his family told him that local builders are hiring in construction. Upon the move, the man obtains a construction job. The young woman did not plan to work. Is anyone eligible for the MEP?</p> <p>Review the basic child eligibility factors:</p>	
✓	<p>1. Age of Eligible Children. The couple meets the age requirement because they are younger than 22 years of age (i.e., 18 and 20).</p>
✓	<p>2. School Completion. Neither one has graduated from high school nor obtained a GED.</p>
✗	<p>3. Move. The couple moved across school district lines (i.e., Texas to Montana) <i>but they are not migratory agricultural workers</i>. Even though the move occurred within the past 36 months (i.e., two months ago) and appears to be the only employment (i.e., economic necessity), they have not met this basic eligibility criteria</p>
✗	<p>4. Purpose of Move. One <i>purpose</i> of the worker's move was to seek or obtain qualifying work.</p> <p>a. The couple did not move to seek or obtain qualifying work. They moved to seek work in construction. Therefore, neither one is eligible for the MEP.</p>
✗	<p>5. Qualifying Work.</p> <p>a. Agricultural or Fishing. Construction is not qualifying work.</p> <p>b. Temporary or Seasonal. Not applicable.</p>
<p>Answer: <u>Not eligible</u>. They are not migratory agricultural workers; they moved for construction work.</p>	

<p>5. Question: A couple with a four-year-old boy moved from Arizona to Georgia three months ago to pick peaches. When they finish picking peaches, the family plans to move up the coast to New Jersey where they will pick blueberries. The money they earn from picking crops is the family's only income. Is the child eligible for the MEP?</p> <p>Review the basic child eligibility factors:</p>	
✓	<p>1. Age of Eligible Children. The child meets the age requirement (i.e., 4).</p>
✓	<p>2. School Completion. The child has not graduated from high school or obtained a GED.</p>
✓	<p>3. Move. The child has moved across school district lines (i.e., Arizona to Georgia) with his parents who are migratory agricultural workers. The move occurred within the last 36 months (i.e., three months ago). The worker moved due to economic necessity as this work is the only income for the family.</p>

✓	<p>4. Purpose of the Move. One <i>purpose</i> of the worker’s move was to seek or obtain qualifying work.</p> <p>a. The family moved to obtain qualifying work (i.e., work in the peach harvest) and obtained the work.</p>
✓ ✓ ✓	<p>5. Qualifying Work.</p> <p>a. Agricultural or Fishing. The work qualifies because it is agricultural work.</p> <p>b. Temporary or Seasonal. The employment qualifies because it is seasonal.</p>
Answer: <u>Eligible.</u>	

<p>6. Question: Anna, age 18, works at a processing plant in Arkansas. Her friends told her that the Tyson plant in Iowa is hiring temporary workers in preparation for this holiday season. Anna moves to Iowa in September of this year to work at the Tyson plant. When she arrives, the Tyson plant hires her to work for a three-month period cutting poultry. This is her only means of income. Assuming that Anna has not graduated from high school and does not have her GED, is she eligible for the MEP?</p> <p>Review the basic eligibility factors:</p>	
✓	<p>1. Age of Eligible Children. The worker meets the age requirement (i.e., 18).</p>
✓	<p>2. School Completion. The worker has not graduated from high school or obtained a GED.</p>
✓	<p>3. Move. The worker has moved across school district lines (i.e., Arkansas to Iowa) on her own as a migratory worker. The move occurred within the past 36 months (i.e., September of this year). The worker moved due to economic necessity as this work is the only income for the worker.</p>
✓	<p>4. Purpose of Move. One <i>purpose</i> of the worker’s move was to seek or obtain qualifying work.</p> <p>a. The worker moved to obtain qualifying work (i.e., agricultural processing) and obtained the work.</p>
✓ ✓ ✓	<p>5. Qualifying Work.</p> <p>a. Agricultural or Fishing. The work qualifies because it is agricultural processing work.</p> <p>b. Temporary or Seasonal. The employment qualifies because it is temporary.</p>
Answer: <u>Eligible.</u>	

<p>7. Question: This past October, a recruiter finds a family with four children (ages 3, 4, 7, and 9) who moved from Mexico to California to harvest various crops. Both parents work in the fields, picking crops. This work is their only source of income. The mother tells the recruiter that they moved from Mexico in March of this same year. When the harvest season is over, the family plans to move back to Mexico. Are the children eligible for the MEP?</p> <p>Review the basic child eligibility factors:</p>	
✓	<p>1. Age of Eligible Children. The children meet the age requirement (i.e., 3, 4, 7, and 9).</p>
✓	<p>2. School Completion. The children have not graduated from high school or obtained a GED.</p>
✓	<p>3. Move. The children have moved across school district lines (i.e., Mexico to California) with their parents who are migratory agricultural workers. The move occurred within the past 36 months (i.e., March 2011). The family moved due to economic necessity as this work is the only source of income for the family.</p>
✓	<p>4. Purpose of Move. One <i>purpose</i> of the worker’s move was to seek or obtain qualifying work.</p> <p style="padding-left: 20px;">a. The family moved to obtain qualifying work (i.e., agricultural crop harvest) and obtained the work.</p>
✓ ✓ ✓	<p>5. Qualifying Work.</p> <p style="padding-left: 20px;">a. Agricultural or Fishing. The work qualifies because it is agricultural work.</p> <p style="padding-left: 20px;">b. Temporary or Seasonal. The employment qualifies because it is seasonal.</p>
<p>Answer: <u>Eligible.</u></p>	

<p>8. Question: During the holiday season, a couple and their two sons (ages 15 and 17) go to their cabin in the neighboring state for a three-four week period. Each year on their vacation, the boys work with a local farmer tending to cattle. The money from this job allows them to earn some extra cash that they use to buy new hunting equipment. Neither son has graduated from high school or earned a GED. Are the children eligible for the MEP?</p> <p>Review the basic child eligibility factors</p>	
✓	<p>1. Age of Eligible Children. The children meet the age requirement (i.e., 15 and 17).</p>
✓	<p>2. School Completion. The children have not graduated from high school or obtained a GED.</p>
✗	<p>3. Move. The family has moved across school district lines (i.e., from one state to another) but neither the parents nor the children are migratory agricultural workers. The move occurred within the past 36 months (i.e., each year). However, the family did not move for economic necessity as the work is not an important part of providing</p>

	a living for the family (i.e., allows them to earn “extra” cash).
✗	<p>4. Purpose of Move. One <i>purpose</i> of the worker’s move was to seek or obtain qualifying work.</p> <p>a. The family did not move in order to see or obtain qualifying work (i.e., it appears that they moved for recreational purposes.</p>
✓ ✓ ✓	<p>5. Qualifying Work.</p> <p>a. Agricultural or Fishing. The work qualifies because it is agricultural work.</p> <p>b. Temporary or Seasonal. The employment qualifies because it is temporary.</p>
	Answer: <u>Not eligible.</u> These are not the children of migratory agricultural workers. The move was not for economic necessity nor was one reason of the move to seek or obtain qualifying work.

<p>9. Question: In May 2007, a family move from Texas to Michigan with their children, ages five and eight, to pick the local crops in season. A recruiter finds them in 2012 and wants to qualify them for the MEP because the family is still picking crops and this is their only means of livelihood. The family has not moved since 2007. Are the children eligible for the MEP?</p> <p>Review the basic child eligibility factors:</p>	
✓	1. Age of Eligible Children. The children meet the age requirement (i.e., five and eight).
✓	2. School Completion. The children have not graduated from high school or obtained a GED.
✗	3. Move. Even though the family did move across school district lines (i.e., Texas to Michigan) and the parents appear to be agricultural workers, the move did not occur within the past 36 months (i.e., May 2007). Therefore, even though the work is due to economic necessity (the family’s only means of livelihood) they are not migratory and have not met ALL the move criteria.
✓	<p>4. Purpose of Move. One <i>purpose</i> of the worker’s move was to seek or obtain qualifying work.</p> <p>a. The family moved to obtain qualifying work (i.e., picking local crops) and obtained the work.</p>
✓ ✓ ✓	<p>5. Qualifying Work.</p> <p>a. Agricultural or Fishing. The work qualifies because it is agricultural work.</p> <p>b. Temporary or Seasonal. The employment qualifies because it is seasonal.</p>
	Answer: <u>Not eligible.</u> The move did not occur within the last 36 months

<p>10. Question: A family with children ages two and six moved from Idaho to Montana two years ago. The father moved to Montana in search of a permanent job as a ranch hand. He was hired to be the crew chief on the farm on a year-round basis. The mother stays at home with children. Are the children eligible for the MEP?</p> <p>Review the basic child eligibility factors:</p>	
✓	<p>1. Age of Eligible Children. The children meet the age requirement (i.e., 2 and 6).</p>
✓	<p>2. School Completion. The children have not graduated from high school or obtained a GED.</p>
✓	<p>3. Move. The family has moved across school district lines (i.e., Idaho to Montana) and the parent is an agricultural worker. The move occurred within the past 36 months (i.e., two years ago). The move appears to be due to economic necessity as it is the family's only income.</p>
✗	<p>4. Purpose of Move. One <i>purpose</i> of the worker's move was to seek or obtain qualifying work.</p> <p>a. The family did not move in order to seek or obtain qualifying work because the father sought a permanent job and obtained one.</p>
✗ ✓ ✗	<p>5. Qualifying Work.</p> <p>a. Agricultural or Fishing. The work qualifies because it is agricultural work.</p> <p>b. Temporary or Seasonal. The employment does not qualify because it is permanent.</p>
<p>Answer: <u>Not eligible.</u> The worker sought and obtained permanent employment, not seasonal or temporary.</p>	

Appendix X: Describing Common Qualifying Work

How to Describe Qualifying Work

A child may qualify for the MEP if the parent, guardian, spouse or child moved due to economic necessity for the purpose of obtaining seasonal or temporary employment in agricultural or fishing work. There are many different types of work that a worker can move to find. Agricultural and fishing work varies from state to state depending on factors like the climate, market conditions, historical crop patterns, and federal and state agricultural policies. Add to this the multitude of fishing, processing, livestock, and other activities, and the list would be long enough to fill a book. Furthermore, some crops and fishing work that qualify in one state, may not qualify in another (e.g., work that is seasonal in a northern state may be done year-round in a southern state). Finally, agriculture and fishing are both dynamic industries and new agricultural and fishing jobs (new crops and seafood products and new production methods) are being created all the time. For these reasons, it would not be possible to list all potentially qualifying agricultural and fishing work. However, the recruiter should have a good understanding of the basic agricultural and fishing employment that qualifies in the state.

When describing qualifying work on a COE, the recruiter should use a gerund (a verb plus “ing” as in “picking”) and a noun (as in “strawberries”). In other words, the recruiter should describe the worker’s action (e.g., “picking”) and the crop, livestock, or seafood (e.g., “strawberries”). Here are some examples of properly written qualifying work:

Picking strawberries	Walking soybeans
De-tasseling corn	Harvesting crabs
Catching chickens	Thinning sugar beet
Planting oysters	

A recruiter should follow this simple format to describe qualifying work. If there is ever a question as to whether a particular agricultural or fishing job qualifies, it is recommended that a recruiter write a clarifying explanation of the work in the comment section. This way the reviewer will have a better understanding of the work upon the initial COE review process.

SEAs are encouraged to develop a list of the agricultural and fishing work that is commonly done by migrant or seasonal farmworkers in their state. Furthermore, the SEA will need to caution recruiters that even if specific agricultural or fishing work appears on the state’s list, for the purposes of the MEP, qualifying work is only considered to be qualifying if (1) the work is temporary or seasonal and (2) performed for wages or personal assistance. Of course, for the children to qualify, the family must meet all other eligibility criteria.

Appendix XI: State-Provided Supplemental ID&R Materials

This manual provides specific information about ID&R for purposes of the MEP, however, there are a number of items that would be helpful to recruiters that were not provided in this manual because they vary from state-to-state. Some of these items are listed below. States may wish to provide some or all of these materials to ensure that recruiters have the information needed to perform their job:

State legislation affecting migrant children:

- Truancy laws, including the state's compulsory age of attendance
- Compulsory attendance policies and consequences for parents
- Child abuse or neglect reporting requirements (including a list of mandatory reporters and instructions for reporting suspected abuse or neglect)
- Minimum immunization requirements to enroll in school

Other state information:

- Staff and program directory
- Organizational chart and the position description or list of responsibilities for various positions (e.g., recruiter, data entry specialist, administrator, state director)
- State map
- Common agricultural and/or fishing work found within the state (chart locations on a state map)
- SEA policies and letters on MEP issues, including eligibility determinations;
- Specific services provided by the state MEP (e.g., accident and health insurance);
- Referral list of local agencies and services (e.g., food, clothing, health, educational, legal)
- State and local action plans
- Ethics and safety policies
- Training opportunities
- State procedures (e.g., mileage reimbursement rules and forms, recruiter weekly activity logs, time-and-effort logs for staff who are paid by more than one program)

Appendix XII: COE Review Checklist¹

Checklist Item	Acceptable	Missing or Unacceptable
A trained (or certified) recruiter completed the COE.		
A new COE is used for each child with a different QAD.		
All blanks are completed and legible (N/A or a dash is entered where needed).		
Corrections are made in red ink, and initialed and dated to distinguish from the original text. Correction fluid should not be used so a record of changes can be maintained.		
All dates are in double digits (i.e., 06/30/11).		
Date of birth is entered correctly. (Any children born <i>after</i> the move are not entered on the COE.)		
The eligibility data are clear and appear reasonable (e.g., the QAD occurred at a time when qualifying work is available; the qualifying work is clear and reasonable).		
“Temporary” or “Seasonal” is selected.		
“Agricultural” or “Fishing” is selected.		
Clear and logical comments are provided where required. (See examples of situations that warrant additional explanation in Chapter 7.)		
City names are spelled correctly.		
State and country abbreviations are correct.		
The parent/guardian is listed, and the signature matches the name.		
The COE is signed and dated by the recruiter.		

¹ Adapted from Texas Education Agency, *2011-2012 Texas Manual for the Identification and Recruitment of Migrant Children* (Austin, 2011).

Appendix XIII: Records Exchange

Section 1304(b)(3) of the ESEA, like provisions of prior ESEA statutes, requires each SEA that receives MEP funds to promote interstate and intrastate coordination of services for migratory children, and provide for educational continuity through the timely transfer of pertinent school records, including information on health, when children move from one school to another, whether or not such move occurs during the regular school year.

History of Records Exchange

ED originally supported a system called the Migrant Student Record Transfer System (MSRTS) built in 1969 and operated by the Arkansas Department of Education in Little Rock, Arkansas. MSRTS provided the capability for state and local migrant personnel to enter student academic, health, and assessment records. MSRTS was centrally-hosted on a mainframe and states could transfer records among states. Forty-nine states used MSRTS and this central repository held data on over 600,000 students.

In 1994, a Government Accountability Office (GAO) report found that MSRTS was slow, incomplete, and used infrequently. Because of the inefficiencies described in the GAO report, MSRTS was terminated in June of 1995.

Once MSRTS was terminated, states began developing their own systems to collect and maintain migrant student data. Private and non-profit vendors developed and provided support for the three major migrant student record systems.

State MEP Systems Descriptions

The following sections provide additional information and descriptions of some of the current MEP information systems.

MIS2000. Within each state that uses it, MIS2000 is implemented as a hierarchical (two-tiered) distributed database. The state-level MIS2000 system includes one master database and one or more regional databases. The regional databases upload regional-level data to the master database on a regular schedule. The master database reconciles the data it receives from the regional level and then pushes the reconciled data back down to the regional-level databases. The master database contains a complete set of data for the entire state.

MIS2000 installations at the state level are customized for state-specific business processes and needs; in fact, the MIS2000 database schema differs from state to state. At the national level, the state-level MIS2000 database hierarchies are linked together via a Transfer Broker and Locator service. These two services collectively provide a nationwide MIS2000 search capability, which effectively creates a national MIS2000 network.

New Generation System (NGS). NGS is a migrant student records management system using a centralized database located in Austin, Texas. Seven states including Texas use NGS and its

centralized database as their migrant student records management system. The NGS user interface is web-based.

COEstar. COEstar, a suite of software that allows individual systems to be customized by computer, was developed 20 years ago by the TROMIK Technology Corporation of North Little Rock, Arkansas. COEstar is currently deployed in Arizona, California, Georgia, New Jersey, and Wyoming. COEstar is used on over 500 computers and serves nearly 50 percent of the nation's migrant children.

MSIN. MSIN is a California statewide system that is updated every fifteen minutes from the California regional-level systems. It is basically a state level database that consolidates the data from all twenty-two regions.

Interstate Locator. The Interstate Locator is an online system that allows users nationwide to search for and request information about migrant students located in California and Arizona. At present, only California and Arizona upload student directory data into the Locator. The online Locator provides for the CA migrant and non-migrant authorized educational staff to track students and view the migrant student records of over 300,000 students.

Washington Migrant Student Information System (MSIS). MSIS is a centralized migrant student records management database. The user interface is web-based. MSIS also provides access to NGS via a button on the user interface. In the MSIS configuration, users access a single centralized database to manage migrant student records. MSIS also currently stores data for Montana and is capable of supporting other states into its centralized database.

Oregon Migrant Student Information System (OMSIS). OMSIS is a centralized database that provides a user-friendly statewide web-based interface that allows accessibility from any workstation that has access to the Internet, a valid user identification, and password. OMSIS is currently used in Oregon and accessed by Washington, California, and other special interest programs.

Migrant Records Exchange Initiative

In order to facilitate the goal of facilitating the transfer of education records between States and LOAs in those States to which migrant children move Section 1308 (b)(1) of the ESEA, as amended by NCLB, requires the Secretary to “assist states in developing effective methods for the electronic transfer of student records and in determining the number of migratory children in each state”. Furthermore, Section 1308(b)(2) requires the Secretary, in consultation with the states to “ensure the linkage of migrant student record systems for the purpose of electronically exchanging, among the states, health and educational information regarding all migratory students.”

Established and administered by ED contract, the Migrant Student Information Exchange (MSIX) is the technology that states use to share educational and health information on migrant children who travel from state to state and who, as a result, have student records in multiple states' information systems. The MSIX works in concert with the existing migrant student information systems that states currently use to manage their migrant data to fulfill its mission to facilitate the appropriate enrollment, placement, and accrual of credits for migrant children nationwide.

The MSIX is a web-based consolidated database of minimum data elements that is populated from the existing state information systems. The state migrant information systems remain the

authoritative sources of the migrant data for their state's students. However, the MSIX makes data on all migrant students available to any state nationwide that has a legitimate need to view the educational and health information on an interstate migrant child. To learn more about MSIX visit: <http://www2.ed.gov/admins/lead/account/recordstransfer.html>.

Appendix XIV: Validating the ID&R System through Re-interviewing

Introduction

Administrators should review ED's *Technical Assistance Guide on Re-interviewing*¹ to gain a full understanding of their quality control responsibilities under the MEP statute and regulations. It is important that each state have a thoughtful quality control system that tests the validity and reliability of child eligibility determinations. Re-interviewing parents, guardians and youth from a representative sample of Certificates of Eligibility (COEs) on an annual basis must be a part of an SEA's quality control system. SEAs are required to use independent re-interviewers to perform this task at least once every three years. This helps validate that the data on the COEs are accurate and that eligibility determinations are correct.²

Re-interviewing

Re-interviewing is the process of checking the eligibility determinations recorded on your state's COEs. It involves independently interviewing families and checking each criterion that makes children eligible for the MEP. Re-interviewing allows confirmation of your state's eligibility determinations and the accuracy of the numbers of migrant children that your state reports. It also helps to identify and fix any problems in your state's ID&R process, and depending on the type of re-interviewing implemented, it can help to establish a discrepancy or defect rate for monitoring and funding purposes. There are two types of re-interviewing: prospective and retrospective.

Prospective Re-interviewing

Prospective re-interviewing is a process that allows for the identification of problems early on so they can be quickly corrected. Prospective re-interviewing is: completed before the state submits child counts every year; conducted annually, at least once every three years an independent reviewer conducts the interviews; performed on the current year's identified migrant children; implemented, ideally, on a rolling basis and as soon as possible after recruiters complete COEs; representative of all determinations made in the state for the year, although it may also focus on areas the state anticipates will have problems (e.g., new recruiters, high risk types of moves, work sites that have both year-round and temporary employment); and, designed to provide an early warning of problems that exist or may develop with the eligibility determination process so that states can take action to find and fix them and can be used to determine a discrepancy rate.

¹ <http://ed.sc.gov/agency/programs-services/88/documents/TechAssistGuideRe-interviewing.pdf>

² October, 2010, Guidance p. 54

Retrospective Re-interviewing

Retrospective re-interviewing establishes valid and reliable defect rates that measure the quality of a state's eligibility determinations for an entire child count year (i.e., eligibility determinations made over the course of a three-year period). Using this information, a state can determine the accuracy of a prior year's child count and, if necessary, revise downward its previously submitted child counts. Retrospective re-interviewing is: undertaken when a state (or OME) suspects a problem is affecting the state's child identification or when the state needs to establish a defect rate; performed on a prior year's eligible children (whose numbers have already been reported); representative of all eligible children in the child count from the designated year; designed to establish a reliable and valid defect rate and to identify the reasons for defects in eligibility determinations; and is capable of directly influencing a state's funding allocations.

As mentioned above, state administrators are responsible for complying with all MEP quality control requirements. ED's complete *Technical Assistance Guide on Re-interviewing* can be found at: <http://www2.ed.gov/programs/mep/mep-reinterviewing-guide-dec-10.pdf>.

Appendix XV: State ID&R Models

Introduction

State Education Agencies (SEAs) are often interested in finding the best way to organize resources of the Title I, Part C, Migrant Education Program (MEP) to conduct ID&R in an efficient and effective manner. While numerous ways of structuring an ID&R system exist, six common approaches can be distinctly identified. The models range from using only a SEA-level recruiter(s) to serve a geographically small state with a numerically small migrant population to a model that requires state and regional level staff, a resource center, and many recruiters employed at many local operating agencies to serve a very large migrant population that is scattered throughout a large state.

Each of the six basic models of organizing for ID&R has advantages and disadvantages. Which model a state selects to operate depends greatly on a number of factors that are specific to each state (e.g., the size, mobility, and residential density of migrant population, the type and schedule of qualifying agricultural or fishing activities that migrant workers seek and engage in, the type of housing available to migrant families, the level of MEP funding, the type of MEP projects offered, etc.).

The Models

The six models discussed in the pages that follow are:

- State Recruiter Model
- Local Recruiter Model
- ID&R Coordinator and Local Recruiters Model
- ID&R Coordinator, State Recruiters, and Local Recruiters Model
- Regional Office Model (1)
- Regional Office and ID&R Center Model (2)

A brief description of each model follows with its advantages and disadvantages. It is hoped that this summary of the six basic models will provide ideas on the best way to organize and/or improve an ID&R system in a particular state.

Model A: State Recruiter

The SEA employs one or more “state recruiter(s)” who conduct all recruitment activities statewide. The state recruiter function is highly centralized and could be performed at the SEA, at a local operating agency (LOA), or through a contract. Typically, states that are small in size and have a small migrant population use model A.

MODEL A: State Recruiter

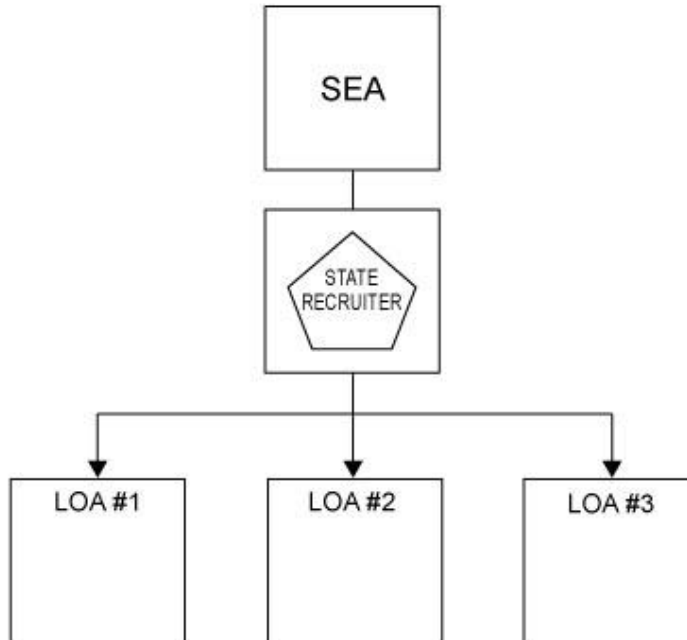

Variations: State recruiter function conducted by one LOA or a contractor. SEA support more than one state recruiter (and office) to provide better coverage for state.

Key Players:

1. MEP Director/Representative
 - Liaison between state and federal government
 - Sets state and local MEP rules
 - Ensures that federal guidelines are adhered to
 - Administers quality control systems
2. State Recruiter
 - State employee(s) or contractor(s) who specialize(s) in identifying and recruiting eligible migrant children
3. Local Operating Agency
 - Receives funds to provide services or make referrals;
 - Does not do actual recruitment, though may notify recruiter if migrant families found

Model A Advantages:

- *Centralized authority.* The state makes all policy and procedural decisions, which increases speed and consistency.
- *Specialization.* One or more staff specialize in ID&R which may result in better-prepared and more knowledgeable recruiters since they can focus exclusively on ID&R (versus part-time recruiters who have many other responsibilities).
- *Consistency.* Having a single person/entity make all eligibility determinations increases the likelihood of consistent practices throughout the state.
- *Less incentive for fraud/abuse.* Statewide recruiters generally have less incentive than local recruiters to make questionable eligibility determinations to increase the numbers so as to prevent a particular local operating agency from being adversely impacted by low or fluctuating numbers.
- *Coverage of non-project areas.* Statewide recruiters typically cover non-project areas, unlike local recruiters who generally remain within project boundaries.

Model A Challenges:

- *Recruiter viewed as an “outsider.”* State recruiters are generally outsiders in communities in which they recruit and therefore may have to work harder to determine where migrant families are likely to reside and to establish the trust and cooperation of migrant families, local growers, other employers, the school, etc.
- *Dependence on skill of state recruiter.* The quality of the recruitment system is dependent on the skill and work ethic of one or a small number of state recruiter(s).
- *Travel time and isolation.* State recruiters are likely to spend a lot of time traveling and feeling isolated and lonely.
- *Coverage.* State recruiters may have a hard time covering all parts of the state during peak enrollment periods when migrant families are arriving in a number of districts simultaneously.
- *Connection with families.* The connection with individual migrant families might not be as strong when one person does the recruitment and others provide services as when the recruiter also provides services (e.g., serves as a liaison with the school, does parent involvement, advocacy, or case-management).
- *Succession planning.* Since the state recruiter is generally the most knowledgeable person in the state regarding the intricacies of student eligibility, when that position is

vacated (e.g., the state recruiter gets sick or takes a new position), it can take a new staff member a long time to master the body of knowledge required by the position.

- *Local ownership.* Local projects may not have the same degree of ownership and interest in the migrant program when a state recruiter does the recruiting.
- *No second checks on COEs.* If a single person does all of the recruiting statewide, there isn't anyone with a comparable level of expertise to do a second review of COEs.
- *Delegation.* The SEA may have a tendency not to pay as much attention to ID&R when they have a statewide recruiter, even though the state is ultimately responsible for the quality/accuracy of child eligibility determinations.
- *Uneven distribution of responsibilities.* The state recruiter may have too many responsibilities and the SEA may have too few. This is also related to delegation, planning as well as implementation, coverage, travel time, and isolation.

Model B: Local Recruiter

Each local operating agency (LOA) employs its own local recruiter with oversight by the SEA (generally through monitoring). The recruitment function is highly decentralized, with direct supervision, training, support, etc., occurring at each LOA. Typically, states that have districts that are geographically spread out and with limited numbers of migrant children use this model. States that use model B are often slightly larger than states that adopt model A.

MODEL B: Local Recruiter

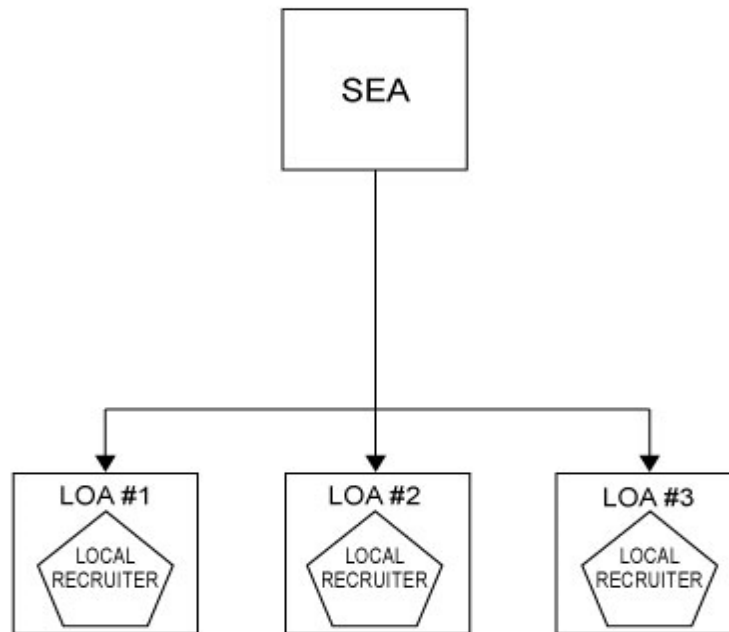

Key Players:

1. MEP Director/Representative
 - Liaison between state and federal Government
 - Sets state and local MEP rules
 - Ensures that federal guidelines are adhered to
 - Administers quality control systems, including verification of Certificates of Eligibility (COEs)
2. Local Recruiter within LOA
 - lives in community
 - knows community
 - not an outsider
3. Local Operating Agency
 - Employs and supports local recruiter

Model B Advantages:

- *Stronger connection with families.* Recruiters are more likely to have stronger connections with individual migrant families and to function effectively as a liaison, advocate, and/or case-manager within the school.
- *Recruiters are “insiders.”* Local recruiters are generally hired from within the community in which they recruit, so they may have an easier time gaining the trust and cooperation of migrant families, local growers, other employers, the school, etc. They also have more opportunities to establish recruitment networks.
- *Less dependent on an individual recruiter.* Since the program employs a number of recruiters, it is less dependent on the skill and work ethic of any one recruiter. Also, recruiters can share ideas and collectively develop more efficient and effective recruiting techniques.
- *Travel time and connection.* Local recruiters don't need to spend as much of their time traveling and they are more likely to feel connected to the local school and community.
- *Coverage.* Since local recruiters have a smaller area in which to recruit, they may have an easier time covering their assigned area during peak enrollment periods when migrant families begin to arrive in large numbers.
- *Succession planning.* Succession planning is easier since there are generally a number of experienced recruiters at any point in time that can help train/mentor new recruiters.
- *Local ownership.* Performing recruitment at the local level may lead to a greater sense of local ownership of the migrant program.
- *Flexible staffing.* Temporary recruiters can be hired for peak enrollment periods rather than a full complement of recruiters year round.
- *Bundle job responsibilities.* Recruiters can also be employed on a full-time basis and can handle other program responsibilities like serving as a family liaison, doing parent involvement, etc.
- *One specialist for each LOA.* The local recruiter and/or specialist will have the opportunity to build stronger relationships with families and stakeholders.
- *More autonomy.* The local recruiter or MEP specialist has specific training and/or experience in ID&R and is able to conduct assignments with greater independence.

- *More resources for project activities.* Human and other resources, particularly time and travel funds, are concentrated on a specific area. Excess can be allocated for other academic and supporting activities.
- *Delegated/shared responsibilities.* The local recruiter and stakeholders have greater involvement, thus increased decision making and more responsibilities.

Model B Challenges:

- *Decentralized authority/consistency.* Decision-making is more decentralized which makes it harder to achieve consistency across the state.
- *Less specialization.* Since recruiters are more likely to have a number of different job duties, they often have less time to spend learning all of the intricacies of child eligibility and therefore may be less knowledgeable.
- *More incentive for fraud/abuse.* Local recruiters may have more temptation to make questionable eligibility determinations to ensure that the number of identified migrant children increases or remains constant so their project doesn't lose money.
- *Coverage of non-project areas.* The state may not have a mechanism in place to cover non-project areas (local recruiters generally recruit only within project boundaries).
- *Coverage outside of the school.* School-based recruiters tend to work solely in the school and not out in the communities where many additional migrant children are found. They may have a tendency to recruit less at work sites and in the community at large which will result in a lack of preschool and OSY recruitment.
- *Different pay scales.* Districts are likely to have different pay rates, so recruiters who are performing essentially the same functions may be paid different rates depending on the district in which they work.
- *Competing demands.* State Directors in most states spend only part of their time working on the MEP and therefore may not have time to play an active leadership role or to have the resources to employ a state recruiter.
- *The possibility of too much local autonomy.* The local recruiters may have too many responsibilities and the SEA may have too few. This is also related to delegation, planning as well as implementation, coverage, travel time, and isolation.
- *Local recruiters may have too many responsibilities.* Schools may expect local recruiters to input MEP data into the system, assist with parental involvement activities, and track student progress in classes. These additional responsibilities leave very little time for ID&R.

Model C: ID&R Coordinator & Local Recruiters

The State Educational Agency (SEA) employs a “State ID&R Coordinator” who provides training, technical assistance, quality control, and related functions for local recruiters that are employed by local operating agencies (LOA) from across the state. While the recruitment function is decentralized, the state ID&R coordinator’s role is to increase the level of standardization and consistency across the state. Typically, mid-size states use this model.

MODEL C: ID&R Coordinator & Local Recruiters

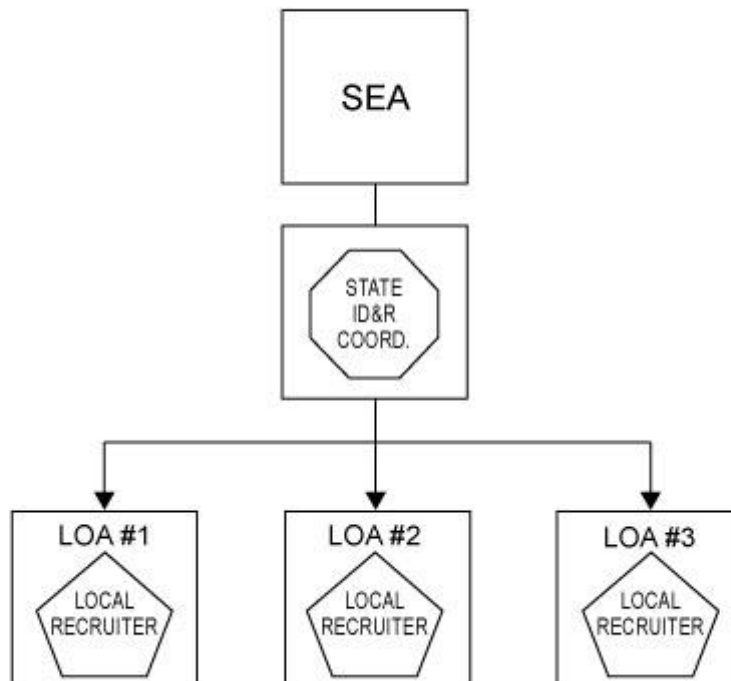

Key Players:

1. MEP Director/Representative
 - Liaison between state and federal government
 - Sets state and local MEP rules
 - Ensures that federal guidelines are adhered to

2. State Coordinator for ID&R
 - Communicates state ID&R policy and standard operating procedures
 - Conducts training
 - Administers quality control systems
 - Monitors work of local recruiters
 - May recruit in non-project areas

3. Local Recruiter within LOA
 - Lives in community
 - Knows community
 - Not an outsider
4. Local Operating Agency
 - Employs and supports local recruiter

Model C Advantages:

- *Consistency/standardization.* This model allows for the advantages of a decentralized system, particularly local ownership and closer relationships with individual families, while providing increased consistency and standardization.
- Many of the same advantages of Models A and B.
- *Increased state and peer support.* These networks can be part of the team building process mentioned above. Communications can occur in person, via telephone, or e-mail on a quarterly basis.
- *Consistent or standardized training.* State ID&R Coordinators are the primary providers of the state's recruitment staff. Centralized training, quality control efforts, and technical assistance leads to more consistent recruitment efforts across the state.

Model C Challenges:

- *Cost.* This model is more expensive to operate than the previous models due to the added cost of the state ID&R coordinator position.
- *Travel.* If the state ID&R coordinator is located in the state (versus a local operating agency or as a contractor), the coordinator may have a difficult time getting state approval to travel or getting approval may be a lengthy process.

Model D: ID&R Coordinator, State Recruiters, and Local Recruiters

Like model C, the SEA employs a state ID&R coordinator who provides training, technical assistance, quality control, and related functions for local recruiters that are employed by LOAs from across the state. The recruitment function continues to be decentralized, and the role of the state ID&R coordinator is to increase the level of standardization and consistency across the state. This model has the added benefit of utilizing a state recruiter to cover non-project areas (the state recruiter could be a contractor or employed by a local LOA). Typically, this type of model would be adopted by a mid-size state.

MODEL D: ID&R Coordinator, State Recruiter & Local Recruiters

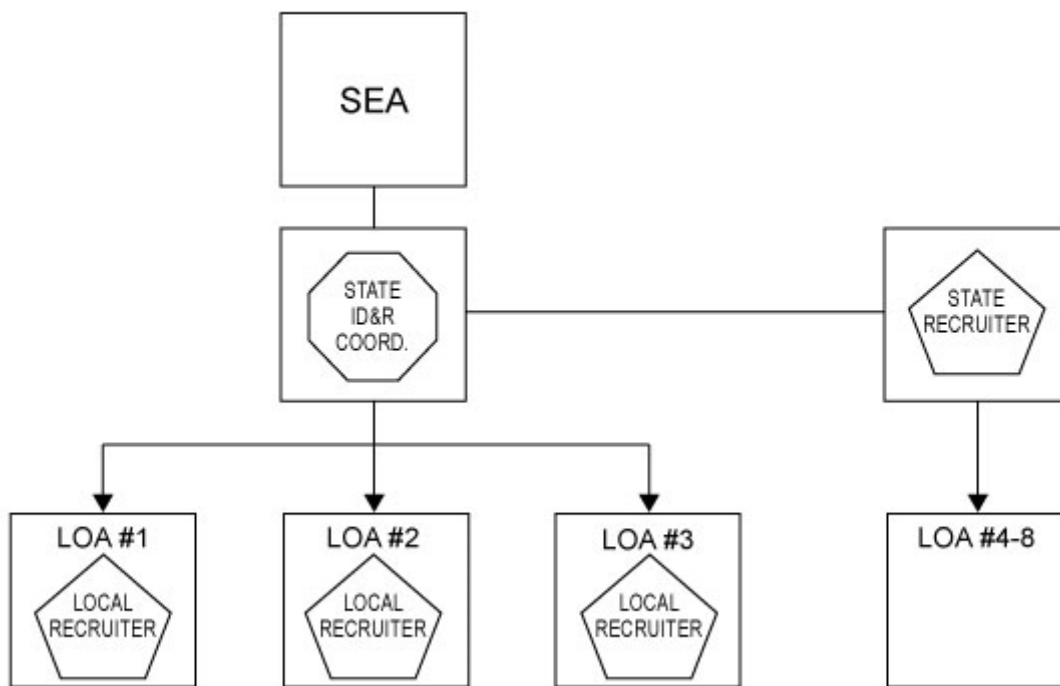

Key Players:

1. MEP Director/Representative
 - Liaison between state and federal government
 - Sets state and local MEP rules
 - Ensures that federal guidelines are adhered to
2. State ID&R Coordinator
 - Communicates state ID&R policy and standard operating procedures
 - Conducts training
 - Administers quality control systems
 - Monitors work of local and state recruiters
 - May recruit in non-project areas

3. State Recruiters
 - State employee(s) or contractor(s) who specialize(s) in identifying and recruiting eligible migrant children outside of the LOA
4. Local Recruiters
 - Lives in community
 - Knows community
 - Not an outsider
5. Local Operating Agency
 - Employs and supports local recruiter

Model D Advantages:

- *Coverage.* The state has greater coverage of non-project areas (i.e., outlying areas where migrant children exist, but that are not current project sites). Also, the state recruiter can “fill in” if a LOA loses a recruiter.
- Many of the same advantages of Models A and B.

Model D Challenges:

- *Cost.* This model is more expensive to operate than the previous models due to the added cost of the state recruiter.

Model E (1): Regional Office

This is a hierarchical, pyramidal model that has a number of organizational levels. Typically the state ID&R coordinator supports a group of regional MEP directors, who supervise regional recruiters and/or provide guidance to local recruiters employed by local operating agencies. The state generally continues to make major policy and procedural decisions, which filter down through the hierarchy. Regional MEP directors and/or local administrators, however, make many of the operational decisions. Generally, this type of model would be adopted by a very large state.

MODEL E (1): Regional Office

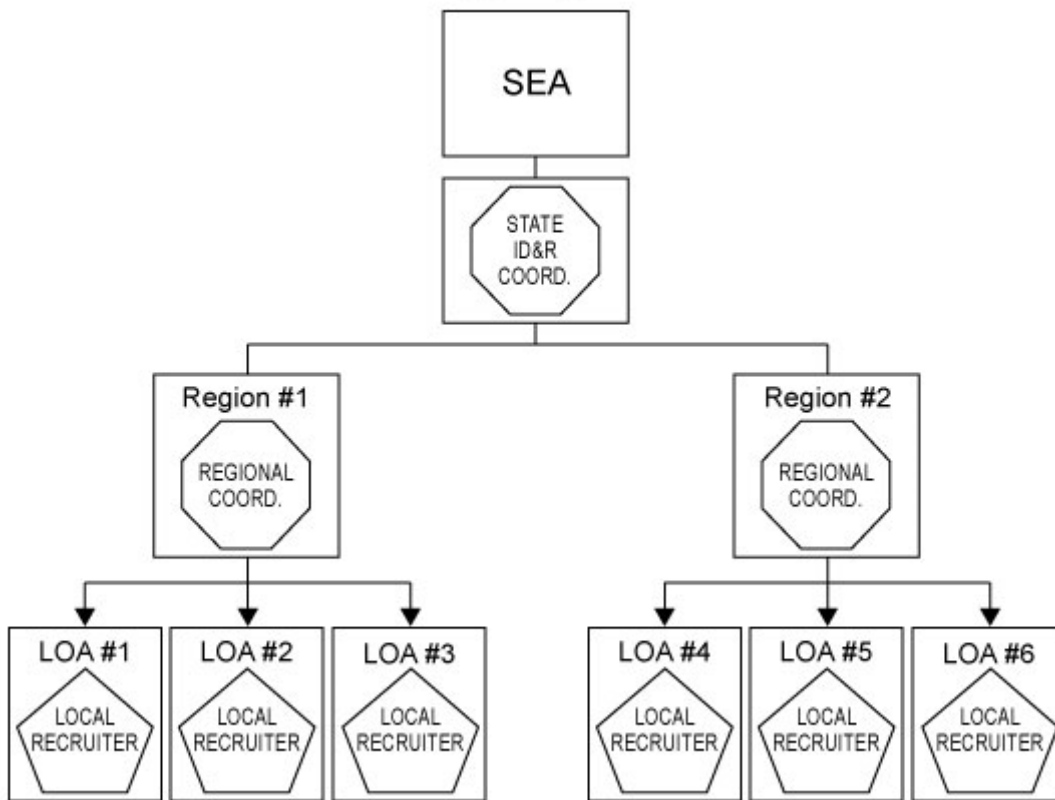

Key Players:

1. MEP Director/Representative
2. State ID&R Coordinator
3. Regional MEP Director
 - Directs operations of regional office (may include either instructional or support services, or both)
 - Supports MEP activities at the LOA level
4. Local Recruiter
5. Local Operating Agency

Model E (1) Advantages:

- *Practical for very large states.* Very large states may need to have a complicated organizational structure like this one because of the large number of recruiters needed to identify migrant families across the state. This avoids overburdening a single decision point, which can create “bottlenecks.”
- *Delegation of authority.* Regional MEP directors have operating responsibility, which (1) frees the state to spend time on strategic decision-making, and (2) promotes flexibility and responsiveness at lower levels in the hierarchy.
- *Task specialization.* Makes more efficient use of employee skills and increases their skill level through repetition.
- *Increased support for recruiters.* There is more technical assistance and support available to ID&R staff at the local levels. Each local operating agency has access to a regional MEP Director (or staff person) that has had training and who has access to a state level counterpart for technical and other assistance.
- *Stronger knowledge base of federal and state policy.* Four of the possible five key players have strong connections to the state MEP: its roles, responsibilities, and resources, including the liaison with the federal program. The knowledge base is gained or strengthened through state-sponsored training and a communications network.
- *Increased statewide coverage.* There is also good coverage for outlying areas where migrant children exist, but do not receive services as well as the capability of repositioning staff in the event of regular or unexpected population shifts.
- *Additional support.* Staff can work in teams.

Model E (1) Challenges:

- *Cost.* This model is expensive because of the number of administrative layers and can be top heavy administratively.
- *Consistency.* There are increased opportunities for variance in policy interpretation and procedures that could impact the implementation of the program.
- *Lack of program cohesiveness.* Regions may become increasingly remote from one another and from the state over time, or alternately, they could become competitive, particularly for funding.

- *Greater need for networking and professional development with peers.* Workload, distance from site to site, and priorities may necessitate individual efforts and even promote adverse competition. A decrease in networking may also weaken the integrity of the state's MEP policy and practices.

Model E (2): Regional Offices & ID&R Center

The model is characterized by having local recruiters receive supervision/instruction from two sources, the LOA and the SEA (typically through a state ID&R coordinator or ID&R Center). Generally, this type of model would be adopted by a very large state that has a large number of migrant children and MEP staff.

MODEL E (2): Regional Offices & ID&R Center

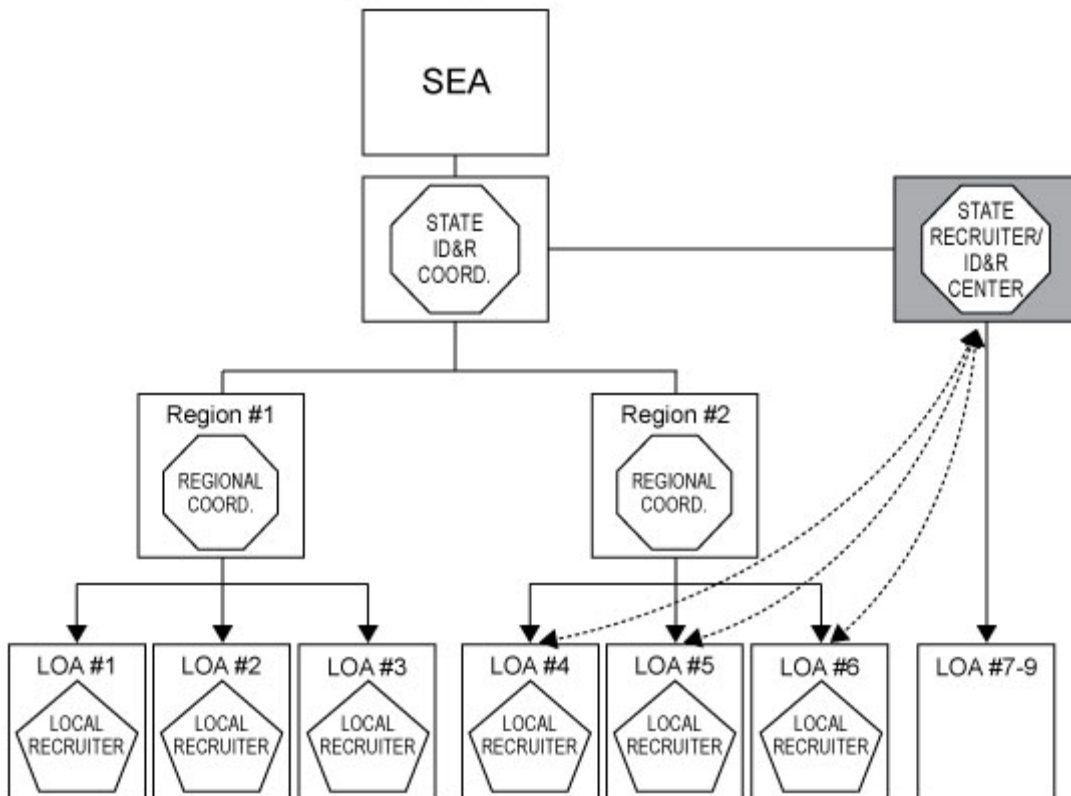

Key Players:

1. MEP Director
2. State ID&R Coordinator
3. ID&R Center Staff
4. State Recruiter(s)
5. Regional MEP Directors
6. Local Recruiter(s)
7. Local Operating Agency

Model E (2) Advantages:

- *Training.* Many opportunities for cross-training/cross-learning.
- *Multiple Staff.* This system is constructed to meet the needs of the entire child.

Model E (2) Challenges:

- *Organizational tension related to multiply supervised employees.* There may be tension between state ID&R staff and regional staff. Recruiters have a direct reporting relationship to the LOA and/or region, yet they receive training and direction on how to perform their jobs from the state ID&R coordinator/center.
- *Cost.* This model is also expensive because of the number of administrative layers.
- *Statewide network.* Though there are resources to meeting the academic and supporting needs of the migrant child, the assignment of roles and responsibilities may not be established.

Appendix XVI: Chapter Checklists

Recruiter Checklist	
Chapter 1: Background and Overview of the MEP	
Did you:	
	Review the common characteristics of migrant agricultural workers and fishers?
	Familiarize yourself with the purpose of the MEP?
	Understand who is eligible to be recruited into the MEP?
	See why it's important to find migrant children?
	Understand how the MEP is organized?
	Recognize how important recruiters are to the process?
Chapter 2: The MEP Recruiter	
Did you:	
	Identify the characteristics of a successful recruiter?
	Familiarize yourself with the recruiter's basic duties and responsibilities?
	Think about how personal emotions can affect the recruiter's behavior toward needy families and youth?
	Think about how important it is to know what services your local migrant education program provides?
	Understand that recruitment is a team effort?
Chapter 3: Learning to Recruit	
Did you:	
	Complete your state's requirements for basic training?
	Read and study the Guidance?
	Review the knowledge and skills needed to identify and recruit migrant children?
	Meet with your supervisor to ask questions, particularly on child eligibility?
	Conduct a "self-check" of whether you understand MEP child eligibility or pass a state survey or test, where required? See Appendix IX.
	Find a knowledgeable mentor?
	Observe one or more experienced recruiters interview a migrant parent or youth?

	Determine where you need more training and request it?
	Identify other recruiters with whom you can share ideas?
	Arrange to be observed by your supervisor?
	Find out where to go to ask questions?
	Provide feedback on ways that the training can be improved?
Chapter 4: Building a Recruitment Network	
Did you:	
	Identify the local organizations and individuals who work most closely with the migrant community?
	Develop profiles of key local employers, school staff, community organizations, and the migrant community?
	Determine the best way to build relationships with each of these key contacts (e.g., find out how they can be assisted, provide awareness training on the MEP)?
	Follow up regularly with key contacts, particularly when they provide leads on local migrant families (e.g., call or visit them, attend important meetings, send thank you notes)?
	Work with schools, community organizations, etc., to see if they will include pre-screening questions for the MEP as part of their enrollment or intake process?
	Create a recruitment map that shows areas where migrant families are likely to live and work, services they use, and where their children go to school?
Chapter 5: Developing Action Plans and & Contacting Families	
Did you:	
	Develop an action plan?
	Canvass areas where concentrations of migrant children and their families are likely to be found (e.g., migrant labor camps, major local employers)?
	Make personal safety provisions (e.g., carry a cell phone with emergency numbers on speed dial, leave a visitation schedule with a responsible coworker, visit potentially dangerous areas during daylight hours and with a partner or team, know the locations of local police stations and hospitals, have reliable transportation, use well-traveled roads)?

Chapter 6: Interviewing Migrant Families and Youth	
Did you:	
	Work with a supervisor to learn the <i>Sample Interview Script</i> ?
	Prepare an introduction to the MEP and a way to “connect” with migrant families or youth?
	Memorize the Basic Child Eligibility Factors?
	Practice asking the numbered questions and probes in the <i>Sample Interview Script</i> ?
	Develop a form or system for taking and saving notes?
	Review the steps to take before, during, and after visiting with a family or youth?
	Think about how to handle people who are uneasy or unwilling to be interviewed?
	Consider how to tell families that they are not eligible?
	Decide how to handle special situations, such as interviewing emancipated youth or someone who speaks another language?
	Prepare for your <i>first</i> interview?
Chapter 7: Determining Eligibility	
Did you:	
	Consider how to best use the <i>Basic Child Eligibility Factors Chart</i> ?
	Talk about how to resolve difficult eligibility cases with your supervisor?
	Discuss your role in quality control?
	Think about the consequences of bending the rules in making eligibility determinations?
	Prepare to make your <i>first</i> preliminary eligibility determination?
	Think about what you would do if you suspected fraud or falsification of national COEs?

Chapter 8: Completing the Certificate of Eligibility	
Did you:	
	Think about how to follow the principles of proper records management?
	Review all of the information that you are required to collect in order to complete a COE, meeting both the national and state requirements?
	Note situations in which you will need to include a written explanation in the comments section of the COE?
	Practice explaining the information in the parent/guardian consent block, including the provisions of FERPA?
	Confirm with your supervisor what your state's process is for reviewing and storing completed COEs?
	Prepare a safe and secure place to store your copies of COEs?
Administrator Checklist	
Chapter 9: Hiring and Training Recruiters	
Did you:	
	Develop guiding questions and a job description to use when hiring recruiters?
	Establish learning objectives for recruiter training (what a recruiter should know and be able to do at the end of the training)?
	Develop a training plan for new recruiters?
	Incorporate classroom, field-based and independent study opportunities into the training?
	Develop advanced eligibility training and ongoing professional development for seasoned recruiters?

Administrator Checklist	
Chapter 10: Planning ID&R Deployment and Supporting Recruiters	
Did you:	
	Consider how best to deploy recruiters on a statewide basis?
	Consider how to support recruiters?
	Consider how to develop programs for mentoring, peer coaching, team building, and peer networking?
	Consider how to evaluate and improve training strategies?
	Decide how and when to assess recruiter performance?
	Understand that employee termination is sometimes necessary?
Administrator Checklist	
Chapter 11: Quality Control in the ID&R System	
Did you:	
	Establish a quality control system?
	Establish a process for re-interviewing selected migrant children (families) each year?
	Establish a process for reviewing COEs, ensuring at least one second party reviews the COE prior to certification?
	Establish a process for resolving eligibility questions?
	Develop procedures and standards for keeping records?

This page left blank intentionally.

Glossary

Glossary

Introduction

The glossary is a conglomeration of definitions taken from several OME sources and are noted by the following parenthetical notations:

Guidance – From the *Non-regulatory Guidance* for Title 1, Part C, Education of Migratory Children MEPAugust, 2010

ID&R Manual – From this publication, the Migrant Education Program Identification and recruitment Manual, U.S. Department of Education Office of Migrant Education, n. d.

Code of Federal Regulations - 34 CFR, § 200.81 - § 200.89.

Agricultural Work

1. The production or initial processing of crops, dairy products, poultry, or livestock; as well as the cultivation or harvesting of trees, that is—
2. Performed for wages or personal subsistence
 - (34 C.F.R § 200.81(a) and Guidance, 2010, p. 24).

Attrition Rate Study

Use of an attrition rate study is one way that a SEA can confirm its basis for reasonably concluding, that certain agricultural work may be considered temporary for purposes of eligibility under the MEP despite the fact that employment at a work site is constant and available year-round. Using the study, an SEA determines that virtually no migratory agricultural or fishing workers remained employed by the same employer for more than 12 months. For those work sites where the results of the attrition rate study reveal that virtually no migratory agricultural or fishing workers remained employed for more than 12 months, the SEA can continue to conclude that workers who perform agricultural or fishing work at those work sites are employed temporarily (See Step 2 of I3 in Guidance, 2010, p. 35.)

In this kind of study, an “attrition rate” means the percent of all migratory agricultural or fishing workers at a particular work site (1) who were previously identified as eligible for the MEP, and (2) whose employment appears to be constant and available year-round, but who do not remain employed at that work site more than 12 months (Guidance, 2010, p.37).

Category 1 Child Count

The Category 1 child count is the 12-month unduplicated statewide total of children who are eligible to be counted for funding purposes. It consists of all of the migrant children ages 3 through 21 who, within three years of a qualifying move, resided in the state for one or more days during the September 1 to August 31 performance period. A "migrant child" must meet the definition in section 1309 of the statute and section 200.81 of the MEP regulations (Guidance, 2010, p. 110).

Category 2 Child Count

The Category 2 child count is the unduplicated statewide total summer/intersession count of eligible MEP project participants who can be counted for funding purposes. It consists of all of the migrant children who were served for one or more days in MEP-funded summer or intersession programs in the state during the September 1– August 31 performance period (Guidance, 2010, p. 110).

Certificate of Eligibility

Also known by its acronym COE. A COE is a form established by the Secretary to document the state's determination of the eligibility of migratory children (34 C.F.R. § 200.89(c)).

Child Count

For purposes of the MEP, a “child count” is the state's numeric calculation of the total unduplicated number of eligible migrant students statewide who can be counted for funding purposes. The Department collects two separate child counts, known as the Category 1 and Category 2 child counts (Guidance, 2010, p. 110).

Comprehensive State Plan for Service Delivery

A comprehensive state plan for service delivery, also known as a state service delivery plan (SDP), describes the services the SEA will provide on a statewide basis to address the special educational needs of migrant students (Guidance, 2010, p. 61).

Consolidated State Performance Report

The Consolidated State Performance Report is the instrument SEAs use to report to ED on the performance of many ESEA formula grant programs, including the MEP (See section 9303 of the statute in Guidance, 2010, p.108.)

Continuation of Service

The statute provides three circumstances in which a local operating agency may continue to provide services to children whose eligibility has ended: (1) A child's eligibility ends during the school term and the agency provides services for the duration of the term (see section 1304(e)(1)); (2) a child's eligibility ends and the agency provides services for an additional school year because comparable services are not available through other programs (see section 1304(e)(2)); and (3) a local operating agency continues to serve secondary school students who were eligible for services in secondary school through credit accrual programs until they graduate (see section 1304(e)(3)). [Note: Before the agency provides services under these provisions, it should consider whether the child's unmet special educational needs are addressed by the general school program and whether migrant children who have a priority for services have already been served (Guidance, 2010, p. 68)].

College Assistance Migrant Program

Also known by its acronym CAMP. “Assists migrant students in completing their first year of college and provides follow-up services to help them continue in postsecondary education” (Guidance, 2010, p. 151).

Cooperative Extension Service

Each state has a “land grant” college or university that addresses agricultural issues and supports a statewide system of Cooperative Extension Service offices. The county agents for each Cooperative Extension office often have in-depth knowledge of local farms and crops, and have many contacts in the farming community. The Cooperative Extension Service may also offer annual statewide activities such as farm shows or agricultural days that are good places to meet employers (ID&R Manual, p. 31).

Crop

A crop is a plant that is harvested for use by people or livestock (Guidance, 2010, p. 25).

Economic Necessity

ED considers this to mean that the worker moved either because he or she could not afford to stay in the current location, or went to a new location in order to earn a living. In general, ED believes that if the worker’s move is related to work (e.g., a move to seek or obtain work, a move because of the loss of work, or a move because of the unavailability of work), the worker moved “due to economic necessity” (Guidance, 2010, p. 14).

Emancipated Youth

An emancipated youth is a child under the age of majority (for a given state) who is no longer under the control of a parent or guardian and is solely responsible for his or her own welfare (Guidance, 2010, p. 11).

Fish Farm

A tract of water, such as a pond, a floating net pen, a tank, or a raceway reserved for the raising or harvesting of fish or shellfish. Large fish farms sometimes cultivate fish in the sea, relatively close to shore. The fish are artificially cultivated, rather than caught, as they would be in “fishing.” Fish species raised on fish farms include, but are not limited to, catfish, salmon, cod, carp, eels, oysters, and clams (Guidance, 2010, p. 27).

Fishing Work

“Fishing work” is the catching or initial processing of fish or shellfish; as well as the raising or harvesting of fish or shellfish at fish farms, that is performed for wages or personal subsistence (34 C.F.R. § 200.81(b) and Guidance, 2010, p. 26).

Guardian

A guardian is any person who stands in the place of a parent to a child (in “loco parentis”) whether by voluntarily accepting responsibility for the child’s welfare or by a court order (Guidance, 2010, p. 12).

High School Equivalency Program

Also known by the acronym HEP. Assists migrant students who are 16 years or older in obtaining a General Education Development (GED) certificate or the equivalent of a high school diploma (Guidance, 2010, p. 151).

Home Base

Many migrant families have a home base or hometown where they live for much of the year. They travel or migrate from this home base to other places to work for temporary or seasonal work out of economic necessity. For example, a migrant family might consider Florida to be their home base. They live in Florida all winter and work through the citrus harvest in the spring, then they move to South Carolina to work during the peach harvest. They might also travel to other states or locations and then return to their home base in Florida in the fall (ID&R Manual, p. 26).

Identification and Recruitment

Identification means actively looking for and finding migrant children. Recruitment means making contact with the family or youth and obtaining the necessary information to document the child's eligibility and enroll the child in the MEP (ID&R Manual, p. 6).

In Order to Obtain

Under § 200.81(c) of the regulations, the phrase "in order to obtain," when used to describe why a worker moved, means that one of the purposes of the move is *to seek or obtain* qualifying work. This does not have to be the only purpose, or even the principal purpose of the move, but it must be one of the purposes of the move (Guidance, 2010, p. 15).

Initial Processing

Is work that (1) is beyond the production stage of agricultural work and (2) precedes the transformation of the raw product into something more refined. It means working with a raw agricultural or fishing product (Guidance, 2010, p. 27-28).

Interstate Coordination

Interstate coordination refers to collaborative activities undertaken by two or more states to improve the education of migrant children in those states. Ideally, this term refers to the collaborative activities that two or more states assume to improve the education of migrant children who move between those states (Guidance, 2010, p. 84).

Intrastate Coordination

Intrastate coordination refers to efforts involving two or more local operating agencies within a state to improve educational services to migrant children in that state. The SEA may facilitate these efforts among local operating agencies or the local operating agencies may conduct them directly (Guidance, 2010, p. 85).

Join Date

Also referred to as "to join" date. In situations where the child and parent do not move together, the "to join" date is the day that the child and worker complete the move to be together. If the child's move precedes the worker's move, the qualifying arrival date is the date that the worker arrived. The reason for this is that a move does not qualify until the worker arrives in the school district and begins to seek qualifying work. Therefore, it is only at this point that the child meets the definition of "migratory child." On the other hand, if the child's move followed the worker's move, the qualifying arrival date is the date the child arrived. The reason for this is that the child does not establish eligibility as a migrant child until he or she physically arrives in the receiving school district

(Guidance, 2010, p. 23). However, the SEA should establish a reasonable time limit for “to join” moves. If the SEA has not established a time limit, the recruiter should determine what is reasonable based on the circumstances. As a rule of thumb, the child’s move should occur within a year of the worker’s move. After one year, it is difficult to establish a credible relationship between the child’s move and the worker’s move. Nonetheless, there may be unusual circumstances that may prevent a child from moving within 12 months of the worker’s move. In that case, the SEA should document the basis for determining that the child is eligible even after a prolonged period of time between the two moves (Guidance, 2010, p. 23).

Leading Questions

Because the interview is critical to determining the child or youth’s eligibility for the MEP, the recruiter should avoid asking questions that “lead” families to give vague or untruthful answers. Leading questions can often be answered by “yes” or “no” responses and prompt the interviewee to give a particular answer. On the other hand, open-ended questions prompt the interviewee to provide more information than simply “yes” or “no.” In the first example below, “you moved here to work in agriculture, right?” makes it appear that “yes” is the “correct” response. Rephrasing the question to “why did you move here?” allows the interviewee to provide various reasons without having a predetermined answer in mind (ID&R Manual, p. 65).

Lessons Learned

In recognition of the experience of the ID&R community, OME has interspersed “lessons learned” from veteran ID&R staff throughout the manual. Lessons learned reflect advice from veteran ID&R staff regarding both strategies to adopt and pitfalls to avoid. These lessons learned help new and veteran recruiters alike benefit from the experience of others (ID&R Manual, p. xii).

Livestock

In general, livestock is any animal produced or kept primarily for breeding or slaughter purposes, including, but not limited to, beef and dairy cattle, hogs, sheep, goats, and horses. For purposes of the MEP, livestock does not include animals that are raised for sport, recreation, research, or pets. ED does not consider the term “livestock” to include animals hunted or captured in the wild (Guidance, 2010, p. 25).

Migrant Education Program (MEP)

The Migrant Education Program (MEP) is authorized by Part C of Title I of the ESEA. The MEP provides formula grants to state educational agencies (SEAs) to establish or improve education programs for migrant children. These grants assist states in improving educational opportunities for migrant children to help them succeed in the regular school program, meet the challenging state academic content and student academic achievement standards that all children are expected to meet, and graduate from high school (Guidance, p. vi). “The general purpose of the MEP is to ensure that migrant children fully benefit from the same free public education provided to other children. To achieve this purpose, the MEP helps SEAs and local operating agencies address the special educational needs of migrant children to better enable migrant children to succeed academically” (Guidance, 2010, p. vi).

Migratory Agricultural Worker

According to section 200.81(d) of the regulations, a migratory agricultural worker is “a person who, in the preceding 36 months, has moved from one school district to another, or from one administrative area to another within a state that is comprised of a single school district, in order to obtain temporary or seasonal employment in agricultural activities (including dairy work).” Note, the regulations also define the terms “move,” “in order to obtain,” “temporary employment,” “seasonal employment,” and “agricultural work” and are included in this glossary (Guidance, 2010, p. 12).

Migratory Child

According to sections 1115(b)(1)(A) (incorporated into the MEP program by virtue of sections 1304(c)(2) and 1309(2) of the statute and §§ 200.81(e) and 200.103(a) of the regulations, a child is a ‘migratory child’ and is eligible for the MEP if:

- (1) The child is not older than 21 years of age; and
- (2) Has not graduated from high school or does not hold a high school equivalency certificate (this means that the child is entitled to a free public education or is of an age below compulsory school attendance); and
- (3) The child is a migrant agricultural worker or a migrant fisher or has a parent, spouse, or guardian who is a migrant agricultural worker or a migrant fisher; and
- (4) The child has moved within the preceding 36 months in order to obtain (or seek) or to accompany (or join) a parent, spouse, or guardian to obtain (or seek), temporary or seasonal employment in qualifying agricultural or fishing work; and
- (5) With regard to the move identified in 4, the child:
 - (a) Has moved from one school district to another; or
 - (b) in a state that is comprised of a single school district, has moved from one administrative area to another within such district; or
 - (c) Resides in a school district of more than 15,000 square miles and migrates a distance of 20 miles or more to a temporary residence to engage in a fishing activity. This provision currently applies only to Alaska (Guidance, 2010, p. 9-10).

Migratory Fisher

According to section 200.81(f) of the regulations, a migratory fisher is “a person who, in the preceding 36 months, has moved from one administrative area to another, or from one administrative area to another within a state that is comprised of a single school district, in order to obtain temporary or seasonal employment in fishing work.” The definition also includes “a person who, in the preceding 36 months, resided in a school district of more than 15,000 square miles, and moved a distance of 20 miles or more to a temporary residence in order to obtain temporary employment or seasonal employment in fishing work. Note, the regulations also define the terms “move,” “in order to obtain,” “temporary employment,” “seasonal employment,” and “fishing work.” The terms are included in this glossary (Guidance, 2010, p. 13).

Move

Under § 200.81(g) of the regulations, “move” or “moved” means “a change from one residence to another residence that occurs due to economic necessity” (Guidance, 2010, p. 14).

MSIX

[The Migrant Student Information Exchange \(MSIX\)](#) system is the technology that allows states to share educational and health information on migrant children who travel from state to state and who as a result, have student records in multiple states' information systems. MSIX works in concert with the existing migrant student information systems that states currently use to manage their migrant data to fulfill its mission to ensure the appropriate enrollment, placement, and accrual of credits for migrant children nationwide (ID&R Manual, p. 78).

Network

The five most common information sources when building a recruitment network are: (1) employers; (2) local school staff; (3) community contacts, organizations, and commercial establishments; (4) other government agencies; and (5) migrant families or youth themselves. Although the recruiter wants to encourage the recruiting network to refer children who might be eligible for the MEP, the recruiter should let network members know that while referrals are appreciated, only those who work for the MEP can determine if a child is eligible to receive services (ID&R Manual, p. 27).

Non-Regulatory Guidance (Guidance)

“This document is designed to help SEAs and local operating agencies use MEP funds to develop and implement supplemental educational and support services to help migrant children. The guidance in this document replaces all prior non-regulatory guidance for the MEP. Compliance with the guidance in this document will be deemed by departmental officials, including the Inspector General, as compliance with the applicable federal statutes and regulations. This guidance does not impose requirements beyond those in the ESEA and other federal statutes and regulations that apply to the MEP. While states may wish to consider the guidance, they are free to develop their own approaches that are consistent with applicable federal statutes and regulations. The guidance in this document is not intended to be prescriptive or exhaustive. This document is one of many resources for SEAs and local operating agencies to use as they determine how best to meet the needs of migrant students in a manner consistent with the requirements of the ESEA. It is intended to be read in conjunction with the authorizing statute, applicable regulations, and the Department’s guidance on other programs (such as Title I, Part A, and Title III) that are relevant to the MEP” (Guidance, 2010, p. vii).

Office of the Inspector General (OIG)

“Congress created the OIG through the Inspector General Act of 1978. Although it reports to the Secretary, it is separate and distinct from the program office units in the Department. The authorizing statute establishes OIG as an independent and objective unit that: Conducts and supervises audits and investigations relating to the programs and operations of the Department; provides leadership, coordination, and recommendations on activities that: (1) promote economy, efficiency, and effectiveness; and (2) reduce or detect fraud and abuse in the administration of programs; and provides a means of keeping the Secretary and Congress informed about problems and deficiencies relating to the administration of the Department's programs and the necessity for corrective action” (Guidance, 2010, p. 143-144).

Parent Advisory Council

Section 1304(c)(3) of the ESEA requires SEAs and local operating agencies to establish and consult with PACs in planning and operating MEP programs and projects of one school year in duration. A

PAC advises the SEA and its local operating agency on concerns of migrant parents that relate to the planning, operation, and evaluation of MEP programs and projects in which their children participate. In particular, the SEA and local operating agency must consult with the PAC about: (1) the comprehensive assessment of the needs of migratory children to be served; and (2) the design of the comprehensive service delivery plan (Guidance, 2010, p. 91).

Personal Subsistence

As used in the definitions of agricultural work and fishing work in § 200.81(a) and (b) of the regulations, and as defined in § 200.81(h) of the regulations, “personal subsistence” means that the worker and the worker’s family, as a matter of economic necessity, consume, as a substantial portion of their food intake, the crops, dairy products, or livestock they produce or the fish they catch (Guidance, 2010, p. 29).

Priority for Services

“Priority for services” children are those who: (1) are failing, or most at risk of failing, to meet the state’s challenging state academic content and student achievement standards; and (2) whose education has been interrupted during the regular school year (Guidance, 2010, p. 69).

Qualifying Arrival Date (QAD)

A child’s eligibility for the MEP begins when the child completes a qualifying move. This is often referred to as the qualifying arrival date (QAD) for purposes of the COE” (Guidance, 2010, p. 23). In situations where the child and parent do not move together, the “to join” date is the day that the child and worker complete the move to be together. If the child’s move precedes the worker’s move, the qualifying arrival date is the date that the worker arrived. The reason for this is that a move does not qualify until the worker arrives in the school district and begins to seek qualifying work. Therefore, it is only at this point that the child meets the definition of “migratory child.” On the other hand, if the child’s move followed the worker’s move, the qualifying arrival date is the date the child arrived. The reason for this is that the child does not establish eligibility as a migrant child until he or she physically arrives in the receiving school district” (Guidance, 2010, p. 23).

Qualifying Move

A move qualifies if: (1) it is a move across school district boundaries; and (2) it involves a change from one residence to another residence; and (3) is made due to economic necessity; and (4) is made in order to obtain qualifying work; and (5) it occurred within the preceding 36 months. Note that the terms “move,” and “in order to obtain” are defined in § 200.81 of the regulations and are also included in this glossary (Guidance, 2010, p. 13).

Qualifying Work

Under § 200.81(i) of the regulations, “qualifying work” means temporary employment or seasonal employment in agricultural work or fishing work (Guidance, 2010, p. 24).

Quality Control

According to § 200.89 of the regulations, an SEA must establish and implement a system of quality controls for the proper identification and recruitment of eligible migratory children on a statewide basis. At a minimum, this system of quality controls must include the following components:

- (1) Training to ensure that recruiters and all other staff involved in determining eligibility and in conducting quality control procedures know the requirements for accurately determining and documenting child eligibility under the MEP.
- (2) Supervision and annual review and evaluation of the identification and recruitment practices of individual recruiters.
- (3) A formal process for resolving eligibility questions raised by recruiters and their supervisors and for ensuring that this information is communicated to all local operating agencies.
- (4) An examination by qualified individuals at the SEA or local operating agency level of each COE to verify that the written documentation is sufficient and that, based on the recorded data, the child is eligible for MEP services.
- (5) A process for the SEA to validate that eligibility determinations were properly made, including conducting prospective re-interviewing as described in paragraph (b)(2).
- (6) Documentation that supports the SEA's implementation of this quality-control system and of a record of actions taken to improve the system where periodic reviews and evaluations indicate a need to do so.
- (7) A process for implementing corrective action if the SEA finds COEs that do not sufficiently document a child's eligibility for the MEP, or in response to internal state audit findings and recommendations, or monitoring or audit findings of the Secretary (34 C.F.R § 200.89).

Re-interviewing

Re-interviewing is the process of checking the eligibility determinations recorded on a state's Certificates of Eligibility (COEs). It involves independently interviewing families and checking each criterion that makes children eligible for the MEP. States can use prospective re-interviewing for quality control before submission of annual child counts. Or states can use retrospective re-interviewing which establishes valid and reliable defect rates that measure the quality of a state's eligibility determinations for an entire child count year (i.e., eligibility determinations made over the course of a three year period).¹

¹ U.S. Department of Education, Office of Elementary and Secondary Education, Office of Migrant Education, *Technical Assistance Guide on Re-interviewing*: Washington, D.C., 20202.
<http://www2.ed.gov/programs/mep/resources.html>.

Seasonal Employment

According to § 200.81(j) of the regulations, seasonal employment is employment that occurs only during a certain period of the year because of the cycles of nature and that, by its nature, may not be continuous or carried on throughout the year (Guidance, 2010, p. 29).

Temporary Employment

Temporary employment is employment that lasts for a limited period of time, usually a few months, but no longer than 12 months. It typically includes employment where the employer states that the worker was hired for a limited time frame; the worker states that the worker does not intend to remain in that employment indefinitely; or the SEA has determined on some other reasonable basis that the employment is temporary. The definition includes employment that is constant and available year-round only if, within 18 months after the effective date of this regulation and at least once every three years thereafter, the SEA documents that, given the nature of the work, of those workers whose children were previously determined to be eligible based on the state's prior determination of the temporary nature of such employment (or the children themselves if they are the workers), virtually no workers remained employed by the same employer more than 12 months (34 C.F.R, § 200.81 (k)).

Unduplicated Count

This is a count in which a given child is only counted once on a statewide basis in a single category (i.e., within a row or with a cell in a row) (RR 11/06/06). An "unduplicated count" is one in which an individual child is included in a state's count only once, regardless of how many places within the state that child may have resided or was served by the MEP. Each SEA is required to submit unduplicated Category 1 and Category 2 child counts (Guidance, 2010 p. 114).

Index

- Achievement, 252, 255
- Action plan, 17, 18, 20, 38, 39, 40, 41, 42, 43, 51, 69, 71, 119, 123, 128, 152, 153, 219
- Administration, 254, 255
- Administrator, ix, 22, 28, 112, 113, 114, 115, 116, 117, 118, 119, 120, 122, 123, 124, 125, 126, 127, 128, 129, 130, 132, 133, 134, 136, 137, 138, 139, 141, 142, 143, 149, 152, 153, 155, 186, 219
- Agricultural activity, 71
- Assessment, 255
- Audits, 254
- Basic Eligibility Factors, 56
- Certificate of Eligibility, vii, 11, 18, 19, 28, 36, 47, 57, 58, 59, 61, 62, 67, 69, 72, 84, 85, 87, 88, 91, 92, 93, 94, 102, 103, 104, 105, 106, 107, 108, 109, 114, 115, 116, 118, 136, 140, 143, 144, 147, 150, 151, 152, 153, 154, 197, 200, 204, 207, 218, 220, 244, 249, 255
- Child, vii, ix, xi, xii, 3, 5, 6, 8, 11, 13, 14, 15, 16, 18, 19, 20, 21, 22, 23, 27, 28, 29, 31, 35, 36, 37, 41, 46, 53, 54, 55, 56, 57, 58, 59, 60, 61, 62, 63, 64, 65, 66, 67, 68, 69, 70, 71, 72, 73, 76, 77, 78, 79, 81, 82, 83, 84, 85, 87, 88, 91, 92, 93, 94, 95, 96, 97, 98, 99, 102, 103, 105, 106, 107, 109, 112, 113, 118, 119, 120, 121, 123, 130, 133, 134, 136, 137, 138, 140, 141, 143, 146, 147, 150, 151, 152, 153, 154, 158, 159, 160, 161, 162, 171, 175, 176, 179, 180, 185, 186, 190, 194, 197, 198, 199, 200, 205, 207, 208, 210, 218, 220, 223, 224, 229, 232, 240, 241, 248, 249, 250, 251, 252, 253, 254, 255, 257
- COE, 106, 154, 249, 255
- College Assistance Migrant Program, vii, 9, 167, 179, 181, 249
- Community, xii, 3, 4, 6, 7, 10, 11, 12, 13, 16, 22, 24, 25, 26, 27, 30, 31, 33, 34, 35, 36, 37, 38, 39, 43, 44, 46, 48, 50, 51, 59, 61, 62, 64, 69, 79, 81, 84, 113, 114, 116, 118, 120, 128, 131, 161, 165, 167, 169, 171, 172, 180, 182, 185, 186, 187, 188, 199, 203, 230, 231, 236, 242, 250, 252, 254
- Contradictions, 66
- Cooperative Extension Service, 31, 172, 250
- Coordination, 16, 17, 113, 120, 121, 222, 251, 254
- Coordinator, 9, 11, 17, 38, 46, 79, 80, 81, 113, 116, 128, 132, 146, 234
- Crop, 25, 26, 40, 41, 60, 78, 100, 170, 218, 250
- Crops, 248, 255
- Culture, 4, 7, 11, 30, 38, 64, 114, 117, 118, 131, 133, 168, 190
- Culture, 3, 18, 22, 37, 57, 64, 92, 115, 117, 118, 168
- Data elements, 223
- Deployment, 112, 127, 128, 129, 135, 142, 245
- Difficult cases, 71, 83, 123, 138, 189
- Draft Non-Regulatory Guidance, vii, ix, 8, 18, 21, 22, 23, 72, 76, 78, 79, 80, 116, 119, 122, 124, 137, 146, 187, 241
- Draft Non-Regulatory Guidance (NRG), vii, 8, 18, 21, 22, 23, 72, 76, 78, 79, 80, 116, 119, 122, 124, 137, 146, 187, 241, 248, 249, 250, 251, 252, 253, 255, 256, 257
- Duty, x, 9, 10, 12, 14, 16, 19, 20, 67, 113, 119, 134, 159, 162, 167, 189, 232, 241
- Education Department General Administration Regulations
EDGAR, vii, 106, 107, 154
- Eight eligibility factors, 55, 57, 70
- Elementary and Secondary Education Act of 1965, 73, 158
ESEA, vii, ix, xi, 4, 158, 164, 249, 252, 254
- Eligibility, vii, ix, x, xii, 2, 5, 6, 8, 9, 10, 11, 12, 13, 14, 15, 16, 17, 18, 19, 20, 21, 22, 23, 24, 26, 27, 28, 29, 31, 33, 34, 36, 37, 38, 40, 46, 47, 53, 54, 55, 56, 57, 58, 59, 60, 61, 62, 63, 64, 65, 66, 67, 68, 69, 70, 71, 72, 76, 77, 78, 79, 80, 81, 82, 83, 84, 85, 86, 87, 88, 89, 91, 93, 98, 102, 104, 105,

- 107, 109, 112, 113, 114, 116, 118, 119, 120, 122, 123, 124, 126, 127, 129, 130, 132, 133, 134, 136, 137, 138, 139, 140, 141, 142, 143, 144, 146, 147, 148, 149, 150, 151, 152, 153, 154, 155, 161, 162, 164, 165, 166, 169, 171, 172, 175, 176, 180, 181, 182, 185, 186, 187, 188, 189, 190, 191, 192, 194, 205, 207, 208, 209, 210, 219, 220, 224, 227, 228, 229, 232, 236, 241, 243, 244, 245, 249, 251, 252, 253, 254, 255
- Eligibility Flowchart, 72, 77, 78, 79, 86, 138, 243
- Emancipated Youth, 70, 243, 250
- Employer, 28, 29, 36, 42, 45, 46, 48, 57, 60, 62, 101, 169, 182, 185, 186, 188, 203
- Employment, xi, 4, 6, 7, 8, 14, 25, 27, 28, 34, 51, 60, 62, 64, 73, 78, 95, 98, 99, 100, 102, 103, 109, 115, 150, 151, 163, 168, 169, 170, 185, 186, 187, 201, 205, 206, 253
- End of eligibility
EOE, vii
- ESEA, 249, 252, 254
- Ethics, 13, 16, 18, 22, 41, 113, 120, 123, 131, 138, 142, 187, 190
- Evaluation, 9, 43, 66, 117, 133, 134, 153, 163, 255
performance assessment, 20, 117
performance assessments, 20, 117, 142
- Even Start, 252
- Falsification, 66, 83, 84, 85, 86, 153, 191, 192, 193, 243
- Family, 2, 6, 7, 11, 12, 13, 16, 18, 23, 26, 27, 29, 33, 34, 35, 36, 37, 46, 53, 54, 55, 56, 57, 58, 59, 60, 61, 62, 63, 64, 65, 66, 67, 68, 69, 70, 78, 79, 82, 87, 92, 93, 94, 98, 99, 104, 109, 118, 119, 130, 132, 137, 147, 149, 150, 151, 152, 158, 164, 168, 170, 182, 185, 186, 191, 194, 195, 197, 198, 199, 200, 201, 202, 203, 205, 207, 208, 209, 218, 231, 241, 243, 251
- Family Educational Rights and Privacy Act, vii, 105, 162, 207
- FERPA, vii, 105, 106, 109, 116, 159, 160, 161, 162, 187, 207, 244
- federal, ix, xii, 4, 7, 8, 9, 13, 14, 18, 19, 21, 25, 76, 79, 80, 83, 85, 105, 107, 109, 115, 116, 123, 124, 137, 146, 149, 158, 159, 161, 163, 165, 167, 170, 172, 180, 182, 186, 190, 191, 192, 218
- Files, 108
- First impressions, 33
- Fishing Activity, 3, 7, 25, 28, 29, 35, 42, 55, 58, 60, 66, 69, 73, 82, 83, 99, 100, 101, 119, 150, 175, 176, 181, 185, 186, 195, 199, 200, 205, 206, 218, 219, 226, 250, 253
- Formula, 249, 252
- Funding, 106, 154, 248, 249
- General Education Development, 198
- General Education Development test, vii, xi, 4, 59, 77, 146, 168, 180, 182, 186, 188, 198, 199, 205, 206, 208, 209, 210, 250
- Guardian, 72, 92, 95, 98, 99, 103, 104, 109, 185, 186, 197, 205, 218, 220, 244, 250, 253
- Head Start, 30, 31, 43, 149, 167, 172
- High School Equivalency Program, vii, 8, 168, 179, 181, 250
- Hiring recruiters, 29, 30, 36, 40, 41, 112, 113, 115, 116, 118, 119, 127, 187, 208, 244
- Home base, 2, 26, 169, 251
- ID&R Forum, 9
- Identification and Recruitment, vii, ix, x, xi, xii, 1, 6, 8, 9, 11, 12, 14, 15, 17, 18, 19, 20, 22, 24, 26, 28, 38, 39, 40, 41, 43, 47, 49, 57, 67, 69, 71, 79, 80, 81, 84, 105, 107, 109, 112, 113, 115, 116, 119, 121, 122, 124, 125, 127, 128, 129, 130, 132, 134, 135, 136, 137, 138, 139, 140, 142, 146, 147, 152, 155, 174, 186, 189, 191, 219, 224, 226, 228, 229, 231, 233, 234, 235, 237, 238, 239, 240, 245, 251, 252
- Immigration and Customs Enforcement, vii
- Incentives, 69, 129, 138
- Inspector General, 254
- Instinct, 81, 82

- Intent, 141
- Interstate Coordination, 251
- Interview, x, 11, 15, 16, 17, 18, 19, 20, 23, 28, 45, 46, 51, 53, 54, 55, 56, 57, 58, 59, 61, 62, 63, 64, 65, 66, 67, 69, 70, 71, 78, 79, 81, 82, 84, 87, 94, 104, 107, 114, 115, 116, 119, 124, 125, 130, 131, 133, 134, 137, 138, 139, 141, 142, 143, 147, 148, 149, 150, 151, 152, 153, 155, 182, 185, 186, 187, 191, 194, 195, 207, 241, 243, 245, 252
- Interview Protocol, 18, 54, 70, 72, 82, 138, 150, 189, 194, 243
- Intrastate Coordination, 251
- Leading questions, 65, 150, 252
- Learning, xi, xii, 4, 10, 12, 15, 18, 20, 24, 33, 34, 43, 56, 84, 121, 124, 125, 126, 127, 132, 140, 163, 232, 240, 241, 242, 244, 252
- Lessons learned, xii, 12, 51, 141, 252
- Local, vii, ix, x, 4, 8, 9, 11, 12, 13, 14, 16, 17, 18, 20, 21, 22, 24, 25, 26, 27, 28, 29, 30, 31, 33, 36, 37, 38, 39, 40, 41, 42, 43, 44, 45, 46, 47, 48, 49, 50, 52, 56, 57, 60, 61, 62, 64, 67, 68, 78, 79, 80, 81, 83, 84, 92, 95, 106, 112, 113, 114, 115, 116, 117, 118, 119, 120, 121, 123, 124, 128, 129, 131, 132, 134, 140, 142, 146, 149, 152, 154, 155, 158, 159, 161, 163, 165, 167, 168, 169, 170, 171, 172, 173, 180, 182, 187, 188, 191, 208, 209, 219, 221, 226, 227, 228, 230, 231, 232, 233, 234, 235, 236, 237, 238, 239, 242, 249, 250, 251, 253, 254, 255
- Local Education Agency, vii, 105, 113, 164, 171
- Local Education(al) Agency, 95
- Local Operating Agency, vii, 8, 95, 106, 113, 149, 152, 154, 227, 228, 230, 231, 233, 234, 235, 236, 237, 238, 239, 240, 249, 255
- Meeting, 20, 21, 22, 35, 36, 37, 39, 44, 45, 46, 130, 131, 133, 136, 137, 140, 142, 144, 152, 242
- meetings, 16, 22, 36, 37, 44, 46, 120, 130, 131, 134, 137, 142, 152, 189, 240
- Mentoring, 15, 19, 22, 23, 122, 129, 130, 131, 135, 189, 231, 241, 245
- MEP, vii, ix, x, xi, xii, 2, 4, 5, 6, 7, 8, 9, 10, 11, 12, 13, 14, 15, 17, 18, 19, 21, 22, 23, 24, 25, 27, 28, 29, 30, 31, 33, 34, 35, 36, 37, 38, 39, 41, 43, 45, 46, 49, 50, 51, 52, 53, 54, 58, 62, 63, 64, 65, 66, 67, 69, 70, 71, 72, 75, 76, 78, 79, 80, 81, 82, 84, 85, 86, 87, 91, 92, 94, 103, 105, 106, 107, 109, 116, 117, 118, 120, 123, 124, 127, 128, 129, 130, 132, 134, 135, 136, 137, 140, 143, 149, 150, 152, 153, 154, 155, 158, 168, 187, 188, 208, 209, 210, 219, 241, 242, 243, 251, 252, 254
- Migrant Education Even Start, 168, 252
- Migrant Education Program, vii, ix, x, xi, xii, 1, 2, 3, 4, 5, 6, 7, 8, 9, 10, 11, 12, 13, 14, 15, 16, 17, 18, 19, 21, 22, 23, 24, 25, 27, 28, 29, 30, 31, 33, 34, 35, 36, 37, 38, 39, 41, 42, 43, 45, 46, 49, 50, 51, 52, 53, 54, 56, 58, 60, 61, 62, 63, 64, 65, 66, 67, 68, 69, 70, 71, 72, 75, 76, 78, 79, 80, 81, 82, 84, 85, 86, 87, 88, 91, 92, 94, 98, 103, 105, 106, 107, 108, 109, 113, 116, 117, 118, 119, 120, 121, 123, 124, 125, 127, 128, 129, 130, 132, 134, 135, 136, 137, 138, 139, 140, 143, 146, 149, 150, 151, 152, 153, 154, 155, 158, 163, 168, 180, 181, 182, 185, 186, 187, 188, 190, 191, 192, 193, 194, 195, 208, 209, 210, 218, 219, 221, 226, 227, 230, 231, 232, 233, 235, 237, 238, 239, 241, 242, 243, 248, 249, 251, 252, 253, 254, 255, 257
- Migrant Education Resource Center, vii
- Migrant Legal Action Program, 31
- Migrant Student Information Exchange, 222, 223
- Migratory agricultural worker, 17, 73, 121, 253
- Migratory child, 55, 73, 79, 222, 251, 255
- Migratory fisher, 73, 253

- Monitoring, 8, 31, 112, 134, 137, 140, 141, 143, 152, 153, 154, 155, 167, 169, 230, 245
- Move, 102, 103, 106, 154, 248, 251, 252, 255
- National Association of State Directors of Migrant Education, vii
- NASDME, vii
- National ID&R Forum, 18
- Needs, 249, 253, 254, 255
- network, 9, 10, 12, 14, 20, 24, 27, 28, 30, 33, 34, 35, 37, 39, 43, 44, 45, 47, 71, 79, 118, 123, 128, 130, 131, 133, 142, 167, 172, 182
- New recruiter, 130, 142
- No Child left Behind Act of 2001, vii, xi, 4, 158, 222
- Office of Migrant Education, ii, vii, xii, 8, 15, 77, 80, 81, 85, 119, 140, 147, 148, 152, 192, 248, 252
- Office of the Inspector General, vii, 85, 151, 153, 192, 254
- OIG, 254
- Out-of-school youth, vii, 6, 15, 17, 19, 24, 25, 36, 48, 53, 67, 68, 91
- PAC, 255
- Parent, 11, 15, 58, 59, 61, 63, 66, 72, 73, 79, 92, 94, 95, 98, 99, 103, 104, 107, 108, 109, 143, 159, 160, 161, 185, 186, 194, 197, 205, 218, 220, 228, 231, 244, 250, 251, 253, 255
- Part A, 254
- Peer coaching, 122, 135, 245
- Personal Subsistence, 248, 255
- Principal Means Of Livelihood, 253
- Priority for Service, 255
- Priority For Services, 249
- Processing, 248, 250
- Production, 248
- Professional development, 21, 22, 44, 113, 118, 123, 124, 127, 133, 142, 144, 244
- Promotion, 5, 37, 38, 48, 69
- QAD, 255
- Qualify, 13, 36, 46, 62, 64, 66, 68, 79, 84, 140, 191, 208, 209, 218, 251, 255
- Qualifying activity, 100, 103, 144, 205, 206, 218, 220
- Qualifying arrival date, 91, 200, 251, 255
- QAD, vii, 91, 93, 98, 105, 143, 152, 220
- Qualifying Arrival Date, 251, 255
- Qualifying move, 64, 95, 98, 106, 154, 248, 255
- Qualifying work, 82, 220, 251, 255
- Quality control, 16, 17, 41, 59, 83, 84, 86, 106, 108, 112, 121, 123, 133, 134, 136, 137, 138, 139, 140, 141, 148, 150, 152, 153, 155, 187, 224, 227, 230, 233, 235, 243, 245
- assurance, 56, 112
- Quality Control, 224
- Records, 29, 60, 66, 78, 79, 87, 94, 105, 106, 107, 109, 116, 151, 153, 154, 155, 159, 160, 161, 168, 221, 222, 244, 245
- Records management, 109, 221, 222, 244
- Recruiter job description, 116, 117, 127, 244
- Recruitment network, 10, 12, 16, 20, 24, 27, 28, 30, 33, 34, 35, 37, 39, 43, 44, 45, 47, 71, 79, 119, 123, 128, 131, 142, 188, 231, 254
- Referrals, 24, 28, 33, 35, 37, 48, 61, 69, 79, 113, 167, 171, 188, 227, 254
- Regulations, vii, ix, 8, 9, 15, 18, 21, 53, 72, 74, 75, 76, 78, 79, 81, 87, 106, 107, 116, 119, 121, 122, 123, 124, 126, 132, 137, 146, 147, 154, 163, 173, 248, 253, 254
- Requirements, ix, xii, 4, 6, 8, 10, 13, 15, 19, 20, 22, 30, 38, 41, 47, 53, 54, 66, 69, 71, 72, 76, 107, 119, 122, 123, 124, 130, 141, 147, 150, 153, 158, 165, 170, 198, 219, 252
- Research, x, xi, 24, 25, 26, 39, 40, 43, 44, 45, 47, 69, 126, 128, 146, 172, 187, 252
- Resistance, 33, 62, 63
- Safety, 16, 18, 22, 39, 41, 49, 50, 51, 52, 57, 113, 170, 173, 187, 188, 219, 242
- Schedule, 29, 42, 43, 44, 46, 50, 52, 57, 142, 221, 226, 242
- School, vii, x, xi, 2, 3, 4, 5, 6, 8, 9, 10, 11, 12, 14, 16, 24, 29, 30, 31, 33, 35, 36, 37, 39, 40, 41, 43, 44, 46, 47, 48, 50, 55, 57, 59,

- 60, 63, 64, 66, 68, 69, 72, 73, 77, 78, 79, 82, 85, 93, 94, 95, 96, 97, 103, 105, 107, 113, 115, 116, 120, 121, 128, 131, 132, 142, 146, 149, 150, 153, 158, 159, 160, 161, 162, 163, 164, 165, 168, 171, 172, 173, 179, 180, 181, 182, 185, 186, 187, 188, 190, 194, 195, 198, 199, 203, 205, 206, 208, 209, 210, 219, 222, 228, 231, 242, 249, 250, 251, 252, 253, 254, 255
- Seasonal, 3, 6, 7, 25, 26, 29, 30, 31, 41, 42, 45, 60, 64, 73, 78, 94, 99, 141, 150, 167, 168, 169, 170, 172, 174, 185, 186, 205, 206, 218, 220, 253
- Seasonal Employment, 116, 253
- Send and receive, 26
- Service Delivery Plan, 255
- Services, 249, 251, 252, 254, 255
- Shuttle migrants, 26, 27
- Special Education, 249, 253
- Standards, 252, 255
- State, vii, ix, x, xi, xii, 3, 4, 6, 7, 8, 9, 13, 14, 17, 18, 19, 21, 22, 23, 25, 26, 30, 31, 32, 36, 38, 40, 41, 42, 43, 47, 55, 56, 57, 58, 60, 61, 62, 63, 68, 71, 72, 73, 76, 77, 78, 79, 80, 81, 83, 84, 85, 87, 88, 92, 93, 94, 95, 96, 97, 104, 105, 106, 107, 108, 109, 112, 113, 115, 116, 119, 121, 122, 123, 124, 125, 128, 129, 132, 133, 134, 136, 137, 140, 142, 143, 144, 146, 147, 149, 150, 151, 152, 153, 154, 155, 158, 159, 161, 165, 166, 167, 168, 169, 170, 171, 172, 173, 181, 186, 187, 189, 190, 191, 192, 198, 199, 209, 210, 218, 219, 220, 223, 224, 227, 229, 232, 233, 235, 236, 240, 241, 244, 250
- State Education Agency, vii, ix, x, 78, 87, 105, 106, 107, 108, 109, 113, 116, 128, 129, 141, 143, 148, 149, 153, 154, 186, 210, 218, 219, 226, 227, 229, 230, 232, 233, 235, 239, 249, 251, 252, 255, 257
- Subsistence, 248, 255
- Supervisor, 8, 9, 11, 12, 13, 14, 15, 18, 20, 22, 23, 24, 36, 40, 42, 43, 44, 45, 55, 61, 66, 71, 78, 79, 80, 81, 84, 85, 86, 106, 109, 134, 138, 149, 189, 191, 192, 210, 241, 242, 243, 244
- support, 2, 3, 4, 7, 8, 9, 13, 14, 22, 30, 31, 35, 37, 41, 55, 63, 78, 81, 123, 124, 128, 130, 132, 134, 135, 141, 142, 149, 151, 154, 168, 169, 170, 172, 180, 181, 182, 185, 186, 189, 197, 202, 221, 230, 237, 238, 245, 254
- Support Services, 254
- Surveys, 32, 35, 36, 37, 42, 129, 174
- Temporary, 3, 6, 7, 25, 29, 30, 42, 45, 46, 55, 60, 64, 67, 73, 78, 94, 141, 149, 150, 169, 170, 174, 185, 186, 199, 205, 206, 208, 218, 220, 253
- Title I, 252, 254
- Title II, 254
- Title III, 254
- To Join, 251, 252, 255
- Tool kit, 188
- Training, xi, 7, 13, 15, 17, 18, 19, 20, 21, 22, 23, 24, 31, 37, 39, 44, 49, 71, 82, 112, 113, 117, 118, 119, 121, 122, 123, 124, 125, 126, 127, 132, 133, 134, 137, 138, 141, 142, 143, 144, 147, 151, 152, 153, 165, 167, 168, 169, 173, 187, 230, 231, 233, 235, 238, 240, 241, 242, 244
- advanced training, 123, 124
- Classroom training, 17, 18, 19, 122, 141
- field-based, 122, 128
- on-the-job, 17
- train, 119, 123, 124, 129, 141, 150, 231
- trainer, 17, 120, 125, 126
- Transportation, 51, 52, 172, 242
- Tutor, 197, 206
- U.S. Department of Education, ii, vii, xi, 71, 85, 124, 153, 162, 163, 167, 192, 248
- ED, ix, 8, 71, 73, 75, 76, 80, 85, 91, 153, 167, 168, 221
- Veteran Recruiter, xii, 15, 17, 53, 252
- Visit, 19, 29, 30, 31, 33, 35, 37, 39, 42, 43, 45, 46, 49, 50, 52, 57, 58, 62, 67, 69, 142, 152, 158, 168, 169, 170, 173, 180, 203, 242
- Warning signs, 82, 83
- Women, Infant and Children

WIC, vii, 31, 170, 171	103, 113, 114, 116, 118, 119, 121, 122,
Youth, vii, ix, x, xii, 3, 5, 6, 7, 8, 9, 10, 11, 12,	123, 129, 132, 133, 134, 138, 143, 144,
14, 15, 16, 17, 18, 19, 22, 24, 25, 27, 28,	150, 151, 152, 172, 185, 186, 187, 189,
30, 35, 36, 38, 40, 41, 44, 46, 51, 53, 54,	190, 191, 192, 193, 218, 219, 243, 250,
56, 57, 58, 59, 62, 64, 65, 66, 67, 68, 69,	251, 252
70, 71, 72, 78, 79, 80, 82, 84, 85, 87,	