



### Syllable Swap

#### Objective

The student will identify syllables in words.

#### Materials

- ▶ Initial syllable cards (Activity Master AP.011.AM1)
- ▶ Final syllable cards (Activity Master AP.011.AM2a - AP.011.AM2c)
- ▶ Student sheets (Activity Master AP.011.SS1a - AP.011.SS1b)
- ▶ Pencils

#### Activity

Students make three words using the same initial syllable.

1. Spread the initial syllable cards face up. Place the final syllable cards face down in a stack. Provide each student with a different student sheet. Students pick up the initial syllable cards that match the initial syllables on their student sheet.
2. Taking turns, students select the top card on the stack and say the final syllable part.
3. Match it to each initial syllable card saying initial syllable first, followed by the final syllable on the card. Do this until the two combined form a word or no word is formed.
4. If word is formed, place final syllable with the initial syllable. Read the word.
5. If no word is formed, place final syllable card on bottom of stack. Note: There will be three words formed with each initial syllable card.
6. Continue until all cards are placed.
7. Record the final syllable and word next to the corresponding initial syllables on the student sheet.
8. Teacher evaluation

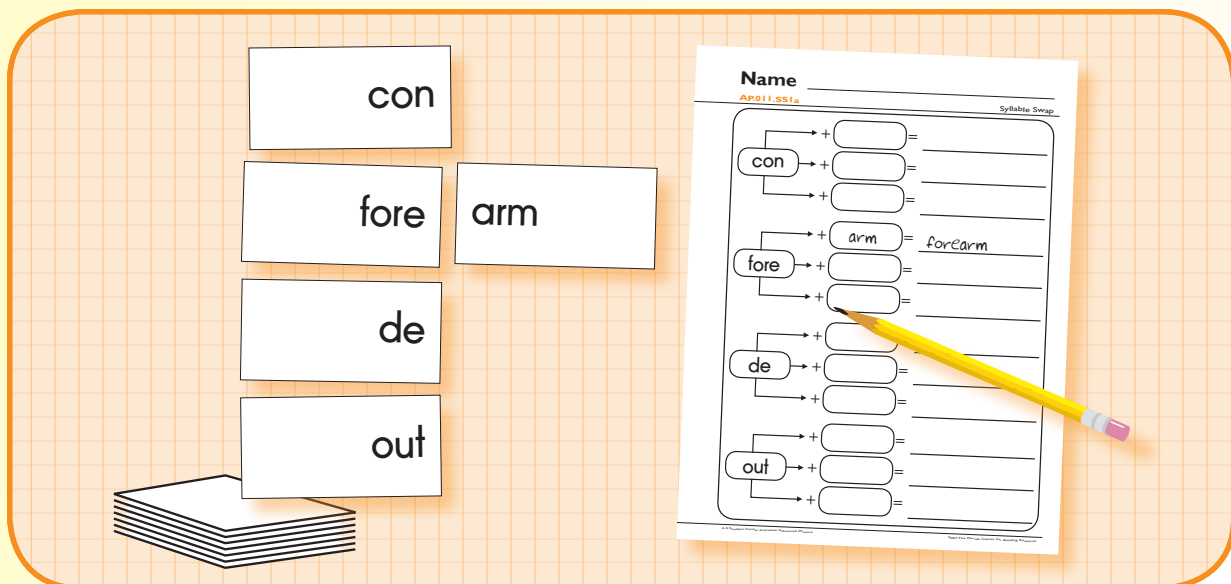

Initial Syllable	Final Syllable	Word
con		
fore	arm	forearm
de		
out		

#### Extensions and Adaptations

- ▶ Make other initial and final syllable cards (Activity Master AP.009.AM2).
- ▶ Use final syllables to make words using multiple initial syllables (Activity Master AP.011.SS2).
- ▶ Use other initial and final syllables (Activity Masters AP.011.SS3 and AP.011.SS4).

# Advanced Phonics

AP.011.AMI

Syllable Swap

con

de

ex

fore

pro

can

com

out

initial syllable cards



# Advanced Phonics

Syllable Swap

AP.011.AM2a

cert

vince

trol

ny

stroy

pend

pect

haust

ist

head

final syllables – answers: concert, convince, control, deny, destroy,  
depend, expect, exhaust, exist, forehead



# Advanced Phonics

AP.011.AM2b

Syllable Swap

arm

word

gram

ton

trude

cel

teen

vas

plex

pete

final syllables – answers: forearm, foreword, program, proton, protrude,  
cancel, canteen, canvas, complex, compete



# Advanced Phonics

Syllable Swap

AP.011.AM2c

bat

come

law

line

final syllables – answers: combat, outcome, outlaw, outline



Name \_\_\_\_\_

AP.011.SS1a

Syllable Swap

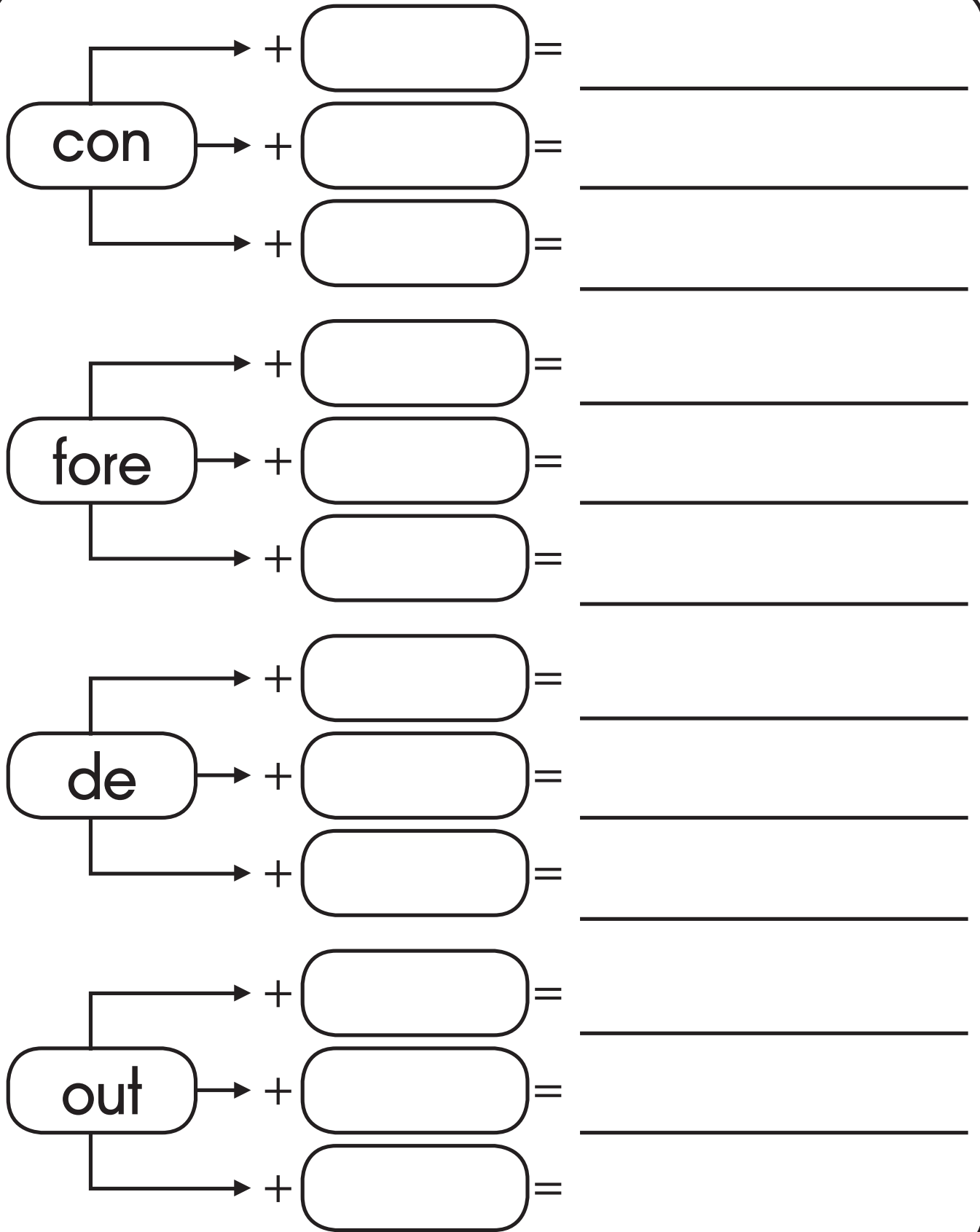

A grid for syllable swap activities. It is divided into four sections, each with a syllable in a rounded rectangle on the left. Arrows point from the syllable to three empty rounded rectangles, each preceded by a plus sign and followed by an equals sign. To the right of each row of three boxes are three horizontal lines for writing.

con	+		=	_____
	+		=	_____
	+		=	_____
fore	+		=	_____
	+		=	_____
	+		=	_____
de	+		=	_____
	+		=	_____
	+		=	_____
out	+		=	_____
	+		=	_____
	+		=	_____

# Name \_\_\_\_\_

Syllable Swap

AP.011.SS1b

ex	+		=	_____
	+		=	_____
	+		=	_____
com	+		=	_____
	+		=	_____
	+		=	_____
pro	+		=	_____
	+		=	_____
	+		=	_____
can	+		=	_____
	+		=	_____
	+		=	_____

Name \_\_\_\_\_

AP.01 I.SS2

Syllable Swap

boun  
ca  
con  
drib

du  
im  
man  
ob

post  
re  
trea  
tum

[ ] +

[ ] +

[ ] +

[ ] +

[ ] +

[ ] +

[ ] +

[ ] +

[ ] +

[ ] +

[ ] +

[ ] +

serve

ble

ty

age

=

=

=

=

=

=

=

=

=

=

=

=

\_\_\_\_\_

\_\_\_\_\_

\_\_\_\_\_

\_\_\_\_\_

\_\_\_\_\_

\_\_\_\_\_

\_\_\_\_\_

\_\_\_\_\_

\_\_\_\_\_

\_\_\_\_\_

\_\_\_\_\_

\_\_\_\_\_



# Name \_\_\_\_\_

Syllable Swap

AP.011.SS3

The worksheet contains four identical sets of syllable swap exercises. Each set consists of a large rounded rectangle on the left containing a syllable structure: a top box with a bracket over the first two syllables, a middle box with a bracket over the first syllable, and a bottom box with a bracket over the first syllable. Three arrows point from these brackets to three empty rounded rectangular boxes. To the right of each empty box is an equals sign followed by a horizontal line for writing the swapped syllable.

# Name \_\_\_\_\_

AP.011.SS4

Syllable Swap

Blank rounded rectangular boxes for syllables, arranged in four groups of three. Each group is connected by a bracket to a larger rounded rectangular box. To the right of each larger box are two horizontal lines for writing.